

TABLE OF CONTENTS

CITY COUNCIL MEETING JULY 17, 2023

<u>Item #</u>	<u>BID #</u>	<u>DESCRIPTION</u>	<u>PAGE</u>
1	2023-443	Planning Conimicut Point Lighthouse Restoration 52059-04321	1-3
2	2024-066	Fire Structural Firefighting Coats & Pants 35-282	4-6
3	2024-080	DPW HVAC Services for City-Owned Buildings 41-331, 42-331, 66-340	7-9
4	2024-068	Fire Radio Communication Equipment Service & Repair 35-340	10-13
5	2022-108	DPW Tire Repairs & Recapping (Sec. 6-12) 65-318	14-28
6	2024-087	City Clerk Probate Court Advertising (Sec. 56-6) 14-203	29-30
7	2024-079	DPW Repair & Rebuild Hydraulic Cylinders 65-314	31-34
8	2024-102	DPW Repair Two Light Fixtures from Motor Vehicle Accidents (Sec. 56-6) 76-357	35-38
9	2024-067	Fire Fire Apparatus Annual Pump Testing & Service 35-330	39-41
10	2024-070	Fire Fire Department Dress Uniforms, Badges, and Accessories 35-260	42-47
11	2024-088	City Clerk City Clerk Advertising (Sec. 56-6) 13-203	48-49
12	2024-089	City Clerk Municipal Court Software (Sec. 56-6) 27-340	50-52
13	2024-108	Fire Multi-Gas Detection Meter Exchange Program (Sec. 56-6) 35-340, 38-814	53-59
14	2024-109	Fire Operations & Asset Management Software (Sec. 56-6) 35-301	60-65
15	2024-103	DPW Buy Out for Big Belly Solar Trash Units (Sec. 56-6) 67-406	66-69
16	2024-086	DPW Pilgrim Senior Center Building Assessment (Sec. 56-10) 510-0400	70-74
17	2023-239	Police Emergency Equipment Repairs for Police Vehicles (Sec. 6-12) 30-330	75-84

Continued next page

TABLE OF CONTENTS

CITY COUNCIL MEETING JULY 17, 2023

<u>Item #</u>	<u>BID #</u>	<u>DESCRIPTION</u>	<u>PAGE</u>
18	2024-098	Fire Code Red Emergency Notification System (Sec. 56-6) 34-354	85-87
19	2024-104	Water Purchase New Kamstrup Water Meter (Sec. 56-6) 84-363	88-106
20	2024-090	City Clerk Code of Ordinances Annual Web Hosting & Administrative Fees (Sec. 56-6) 13-228	107-108
21	2024-015	Police SWAT Team Headsets with Mounting Hardware (Sec. 6-12) 33-355	109-125
22	2024-105	DPW Purchase Lumber for Salt Barn (Sec. 56-6) 66-369	126-128
23	2024-106	DPW Maintenance Agreement for Mail Machine (Sec. 56-6) 78-205	129-138
24	2024-107	DPW Purchase Dugout Benches for City Park (Sec. 56-6) 510-0400	139-141
25	2023-190	Police Police Automotive Graphics Replacement (Sec. 6-12) 30-330	142-159
26	2024-099	DPW Municipal Recycling Facility By Products (Sec. 56-6) 68-956, 68-958, 68-959, 68-999	160-161

RFQ2023-443 Conimicut Point Lighthouse Restoration

- 4 bids received

CODE: 52059-04321 Community Development – Earmark Conimicut Lighthouse Restoration

MANNER OF AWARD: \$775,000.00
One Year from Date of Award

RECOMMEND: Abcore Restoration Company, Inc.

Abcore Restoration Company, Inc.
2 Secluded Drive
Narragansett, RI 02822

Cavanagh Marine, Inc
152 Bears Den Road
Tiverton, RI 02878

Cape Cod Builders Inc.
14 Bosuns Lane
Bourne, MA 02523

Valley Restoration, LLC
PO Box 665
Litchfield, CT 06759

**CITY OF WARWICK****FRANK J. PICOZZI, MAYOR**

Memorandum

To: Francis Gomez, Purchasing Agent
From: Tom Kravitz, City Planning Director TK
Date: 6/28/2023
Subject: RFP #2023-443

The City of Warwick solicited qualifications for qualified firms to provide consulting services for proposed maintenance to the Conimicut Shoals Lighthouse. This project includes restoration work to the lighthouse and installation of an educational kiosk at Conimicut Point Park.

This project is funded in part by a \$775,000 congressional earmark sought by former Congressman Langevin (Earmark grant# B-22-CP-RI-824).

Based on a review of the proposals, the firm that rated most highly by the Planning Department by way of qualification and local experience within Narragansett Bay was *Abcore Restoration Company, Inc.* (2 Secluded Drive, Narragansett, RI).

Staff is seeking authorization from the City Council to negotiate with *Abcore Restoration Company, Inc.*, in hopes of determining a precise cost estimate and scope of work based on the limited funds available above and beyond the congressional earmark.

Please feel free to contact me with any questions.

RFQ2023-443 Conimicut Lighthouse Restoration					
The following vendors were sent specifications					
<u>VENDOR</u>	<u>ADDRESS</u>	<u>CITY</u>	<u>STATE</u>	<u>ZIP</u>	<u>EMAILS</u>
ABCORE Restorations Inc.	557 Indian Corner Road	North Kingstown	RJ	02852	abc@cox.net
H&L Contracting	140 Adams Ave. Suite B14	Hauptpage	NY	11788	info@hlcontractingllc.com
Spartan Construction General Contracting, Inc.	399 Oak Street, Suite C	South Amboy	NJ	08879	office@spartanconstructionll.com

Bid2024-066 Structural Firefighting Coats & Pants

- 1 bid received

CODE: 35-282 Fire Department – Turnout Gear

MANNER OF AWARD: \$125,000.00
9/12/2023 – 3/11/2024

RECOMMEND: Fire Tech & Safety

Fire Tech & Safety
100 Business Park Drive Unit 6-9
Tyngsborough, MA 01879

ITEM #	Description	Make and Model	Price
1	Structural Firefighting Coat	Lion V-Force	\$1,685.00
2	Structural Firefighting Pant	Lion V-Force	\$1,200.00
3	Replacement Suspenders (to be the same as would normally be included with pant purchase)	Lion V-Back	\$98.00



Jason Umbenhauer
Assistant Chief

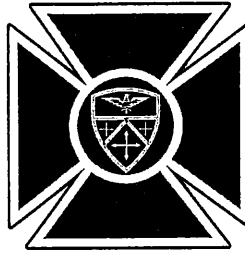

Office: (401) 468-4044
Fax: (401) 468-4043

Warwick Fire Department
111 Veterans Memorial Drive
Warwick, Rhode Island 02886

June 28, 2023

Francis Gomez
Purchasing Agent
City of Warwick

The bid for *Structural Firefighting Coats & Pants, Bid#2024-066* has been carefully reviewed by the Fire Department.

One (1) vendor submitted a bid, and after evaluating pricing the following vendor has fully satisfied the specifications outlined in our request. The Fire Department is recommending that the bid be awarded to the following vendor:

Fire Tech & Safety, Tyngsborough, MA

The purchase of these products is necessary for the Fire Department's annual replacement cycle of Turnout Gear as specified in NFPA 1851. This standard requires replacement of turnout gear that does not meet inspection/testing standards or turnout gear that has meet the maximum service life of 10 years.

The current bid expires on 9/11/23 and the Fire Department is requesting a 6-month award, for an amount not to exceed \$125,000. Funding for this product will be from budget code 35-282 Turnout Gear.

Please contact me should you have any questions.

Jason Umbenhauer
Assistant Chief

VENDORS Structural Firefighting Coats and Pants 6/30/2023

Bid2024-066 Structural Firefighting Coats & Pants						
The following vendors were sent specifications						
VENDOR	ADDRESS	CITY	STATE	ZIP	EMAILS	
911 Safety Equipment	329 E. Main St	Norristown	PA	10401	sales@911se.com	
American Fire Equipment Co.	58 Norfolk Ave	So. Easton	MA	02375	dave@amfire.net	
Brigham Industries	15 Brigham Road	Paxton	MA	01612	tim@amfire.net	
C & S Specialty, Inc.	1181 Old Smithfield Road	North Smithfield	RI	02896	sheroux@csspecialty.com	
Chief Supply Corp.	PO Box 481912	Charlotte	NC	28269	carolynB@chiefssupply.com	
East Coast Emergency Outfitter	801 Perimeter Rd	Manchaester	NH	03103	andrew@emergencyyoutfitter.net; damaris@emergencyyoutfitter.net	
Ed Lyons Fire Equipment, Inc.	1643 Central Street	Stoughton	MA	02072	edlyons@edlyonsfire.com	
ElizacCo	399 Pleasant Ave	Hamburg	NY	14075	Elizabeth@ellizaco.com	
Fire Tech & Safety of New England, Inn.	90 Progress Ave	Tyngsborough	MA	01879	jlangevin@firetechusa.com; rconway@firetechusa.com	
Firematic Supply Co.	23 Beach Street	Milford	MA	01757	cporitier@firematic.com	
GearGrid Corporation	670 S.W. 15th St	Forest Lake	MN	55025	sales@geargrid.com	
New England Fire Equipment & Apparatus Corp.	10 Stillman Road	North Haven	CT	06473	nefea@aol.com	
Northeast Rescue Systems	280 Milton Street R-1	Dedham	MA	02026	poconnor@northeastrescue.com; pburke@northeastrescue.com	
Safeware, Inc	4403 Forbes Blvd	Lanham	MD	20706	info@safewareinc.com	
Shipman's Fire Equipment Co.	172 Cross Road P.O. Box 257	Waterford	CT	06385	info@shipmans.com; ccentracchio@shipmans.com	
Yankee Equipment Systems, Inc.	PO Box 630	Barrington	NH	03825	mbuck@yankeeequipment.com; tdonovan@yankeeequipment.com	

Bid2024-080 HVAC Services for City-Owned Buildings

- 3 bids received

CODE: 41-331 Thayer & Warburton Arenas – Building Maintenance \$15,000.00
 42-331 McDermott Pool – Building Maintenance \$15,000.00
 66-340 Building Maintenance – Service Contracts \$50,000.00

MANNER OF AWARD: \$80,000.00
 8/30/2023 – 8/29/2024

RECOMMEND: Phalanx Engineering

Phalanx Engineering
 110 Byfield St.
 Warwick, RI 02888

Temptec Mechanical LLC
 84 Sprague St.
 Providence, RI

Arden Engineering Constructors, LLC
 505 Narragansett Park Drive
 Pawtucket, RI 02861

Item	Description	Phalanx	Temptec	Arden
A	Repair Service			
1.	Hourly Labor Rate Mechanical Contractor Master "A" Or Refrigeration Contractor Master Class I or Pipefitter Contractor Master Class I			
	Normal Hours	\$115.00	\$124.95	\$159.00
	Overtime Hours	\$172.50	\$184.95	\$234.00
	Weekend Hours	\$172.50	\$184.95	\$282.00
2.	Hourly Labor Rate Refrigeration – Journeyman Class I			
	Normal Hours	\$115.00	\$124.95	\$135.00
	Overtime Hours	\$172.50	\$184.95	\$199.00
	Weekend Hours	\$172.50	\$184.95	\$239.00
3.	Hourly Labor Rate Other (if needed)			
	Normal Hours	\$94.00	\$99.00	\$135.00
	Overtime Hours	\$141.00	\$146.00	\$199.00
	Weekend Hours	\$141.00	\$175.00	\$239.00
B.	Parts			
1.	Cost Plus %	20%	20%	20%



CITY OF WARWICK
DEPARTMENT OF PUBLIC WORKS
925 SANDY LANE • WARWICK, RHODE ISLAND 02889
TEL (401) 738-2003 • FAX (401) 732-5208

JUN 29 2023

FRANK J. PICOZZI
MAYOR

ERIC J. EARLS, PE
DIRECTOR OF PUBLIC WORKS

To: Francis Gomez, Purchasing Agent

From: Eric J. Earls, Public Works Director *EJE*

Date: June 29, 2023

Subj: Bid2024-080 HVAC Maintenance & Repair for City -Owned Buildings

We have reviewed the three bids submitted for the above and recommend award, Phalanx Engineering as the lowest responsible bidder for the necessary repairs and maintenance to HVAC systems in City owned facilities.

The current bid expires on August 29, 2023. The new contract period will be August 30, 2023 to August 29, 2024. The recommended cap is \$80,000.00 for a one-year period.

(66-340 - \$50,000)

(41-331 - \$15,000)

(42-331 - \$15,000)

VENDORS HVAC Maintenance

Bid2024-080 HVAC Maintenance & Repairs at City-Owned Buildings						
The following vendors were sent specifications						
VENDOR	ADDRESS	CITY	STATE	ZIP	EMAIL	
Allen Engineering, Inc.	121 Prospect St.	Warwick	RI	02886	allenengineering86@yahoo.com	
Arden Engineering Constructors, LLC	505 Narragansett Park Dr.	Pawtucket	RI	02861	etessier@ardeneng.com	
Atlantis Comfort Systems Corp.	111 Energy Way	W. Warwick	RI	02893	info@atlantiscomfort.com	
Automatic Temperature Controls, Inc.	95 Connecticut St.	Cranston	RI	02920	slusster@autotempcontrols.com;smazzie@autotempcontrols.com	
CAM HVAC & Construction	116 Lydia Ann Rd.	Smithfield	RI	02917	adam@camhvac.com; cathy@camhvac.com; candrade@camhvac.com	
CIMCO Refrigeration	121 N. Plains Industrial Rd. Unit L	Wallingford	CT	06492	onegrin@toromont.com	
Climate Masters	66 Clark Rd.	Smithfield	RI	02917	GBigCasino@cox.net;401climatemasters@gmail.com	
D Larsen	2 Huckleberry Ave.	Warwick	RI	02888	dlarsenandsons@gmail.com	
Ductworks HVAC Service & Installation	84 Green St.	N. Smithfield	RI	02896	mat@him-mechanical.com	
Elmhurst Engineering	255B Pawtuxet Ave.	Warwick	RI	02888	Paulc28205@aol.com	
Environmental Systems, Inc.	2980 West Shore Rd.	Warwick	RI	02886	jmahoney@envsys.net;info@envsys.net;mmuratori@envsys.net	
Evergreen Plumbing and Heating	2 Evergreen Ave	Warwick	RI	02888	evergreenplumbingri@gmail.com	
GEM Plumbing & Heating	One Wellington Rd.	Lincoln	RI	02865	lengemma@gemplumbing.com;sserrecchia@gemplumbing.com;gcosgro@gemplumbing.com	
Greenwood Plumbing & Heating	5 Minnesota Ave #1	Warwick	RI	02888	greenwoodplumbingheating@gmail.com	
Nexgen Mechanical, Inc.	81 Bleachery Ct. Unit 3	Warwick	RI	02886	jim@nexgenmechanical.com; Luanne@nexgenmechanical.com; slamers@nexgenmechanical.com	
Phalanx Engineering	110 Byfield St.	Warwick	RI	02888	atastarian@phalanxeng.com	
Premier Heating & Cooling, LLC	125 Elder St.	Lincoln	RI	02865	premierheatingandair@yahoo.com	
Regan Heating and Air Conditioning	235 Georgia Ave	Providence	RI	02905	info@reganhvac.com	
Sarra Engineering	1 Harry St.	Cranston	RI	02907	justin@sarraengineering.com	
Seekonk Heating Services, Inc.	911 Taunton Ave.	Seekonk	MA	02771	billshs@msn.com	
Sensible Heating & Air Conditioning, LLC	90 Highview Ave.	Hope Valley	RI	02832	sensibleairconditioning@yahoo.com	
Tempotec Mechanical LLC	84 Sprague St.	Providence	RI	02907	ismail@tempotecri.com	
United Mechanical, Inc.	Two Starlinie Way, Unit 4	Cranston	RI	02921	steve@unitedheatingsvc.com	

Bid2024-068 Radio Communication Equipment Service & Repairs

- 1 bid received

CODE: 35-340 Fire Department – Service Contracts

MANNER OF AWARD: \$48,000.00
10/2/2023 – 10/1/2025

RECOMMEND: Cyber Communications, Inc.

Cyber Communications Inc.
90 Colorado Ave.
Warwick, RI 02888

Pricing as Follows



Jason Umbenhauer
Assistant Chief

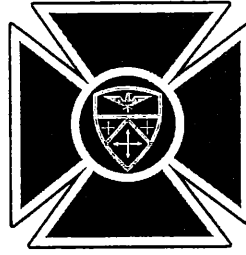

Office: (401) 468-4044
Fax: (401) 468-4043

Warwick Fire Department
111 Veterans Memorial Drive
Warwick, Rhode Island 02886

June 28, 2023

Francis Gomez
Purchasing Agent
City of Warwick

The City of Warwick Fire Department has reviewed *Bid2024-068 Radio Communication Equipment Service & Repair*.

The City received only one (1) response to our bid request, therefore the Fire Department recommends that the bid be awarded to:

Cyber Communications, Inc., Warwick, RI.

Cyber Communications has provided reliable service on the Fire Department's radio communication system for over 25 years. Cyber Communications possesses the technical experience and knowledge of the Fire Departments radio system that is required to mitigate an emergency equipment failure. Cyber Communications has a repair facility within the City of Warwick and employees enough technicians to be able to respond to our emergency requests in a timely fashion. Cyber Communications is focused on Public Safety and provides services to over 50 Fire Departments and 100 Police Departments.

The current bid expires on 10/1/23 and, if approved, the new bid will have an effective date of 10/2/2023 through 10/1/2025, for a total amount not to exceed \$48,000. Funding for this service will be from budget code 35-340 Service Contracts.

Please contact me should you have any questions.

Jason Umbenhauer
Assistant Chief

Email: Jason.Umbenhauer@warwickri.gov

2024-068 Radio Communication Equipment Service & Repair BID RESULTS

Item	Description	Price Year 1	Price Year 2
A	Normal Business Hours Rate (per hour) for repair and/or Installation of items not covered by fixed site equipment monthly maintenance contract	\$ 160.00	\$ 160.00
B	After Business Hours Rate for Nights & Weekends (per hour) for repair of items not covered by fixed site equipment monthly maintenance contract	\$ 240.00	\$ 240.00
C	After Business Hours Rate for Holidays (per hour) For repair of items not covered by fixed site equipment monthly maintenance contract	\$ 320.00	\$ 320.00
D	Normal Business Hours Rate (per hour) for Installation of radio equipment	\$ 160.00	\$ 160.00
E	Percentage off list price for parts not covered under fixed site equipment monthly maintenance contract	10%	10%
F	Monthly Maintenance Contract (per month) for Two (2) Motorola MCC 7500 Dispatch Consoles	\$ 300.00	\$ 300.00
G	Monthly Maintenance Contract (per month) for Two (2) Motorola MCG8000 Gateways	\$ 32.00	\$ 33.00
H	Monthly Maintenance Contract (per month) for Eventide Nexlog 740 DX-Series Data Recorder	\$ 68.00	\$ 70.00

Bid2024-068 Radio Communications Equipment Service & Repair						
The following vendors were sent specifications						
VENDOR	ADDRESS	CITY	STATE	ZIP	EMAILS	
Cyber Communications	90 Colorado Ave	Warwick	RJ	02888	chainley@cybercomminc.com; prush@cybercomminc.com; tpostler@cybercomminc.com	
Industrial Communications	40 Lone Street	Marshfield	MA	02050	wireless@induscom.com	
Radio Phone Communications	153 James P Murphy Industrial Hwy	West Warwick	RJ	02893	sales@radio-phone.com	

CODE: 65-318 Automotive – Tire Recapping

SECTION 6-12

Request permission to increase PCR-112-21 (Sub A) from \$280,000.00 to \$315,000.00

Bid2022-108 Tire Repairs & Recapping

Sullivan Tire Co., Inc.
1199 Jefferson Blvd.
Warwick, RI 02886

LAST ACTION TAKEN

Award (Bid): PCR-112-21 (Sub A) approved on September 2, 2021 in the amount of \$280,000.00.
Contract period September 8, 2021 through September 7, 2023.

Contract Increase Requested:	\$35,000.00
Current Contract Award:	\$280,000.00
Contract Period Requested	9/8/2023 – 12/31/2023
Current Contract Period	9/8/2021 – 9/7/2023

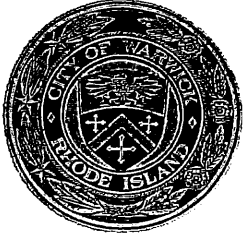

CITY OF WARWICK
DEPARTMENT OF PUBLIC WORKS
925 SANDY LANE • WARWICK, RHODE ISLAND 02889
TEL (401) 738-2003 • FAX (401) 732-5208

FRANK J. PICOZZI
MAYOR

ERIC J. EARLS, PE
DIRECTOR OF PUBLIC WORKS

To: Francis Gomez, Purchasing Agent

From: Eric J. Earls PE, Director of Public Works *EJE*

Date: June 27, 2023

Subj: Bid2022-108 Tire Repairs and Recapping

The above was awarded by the City Council for tire repairs and recapping for City vehicles for a contract that commenced on September 8, 2021 for a two year period. In an effort to streamline the services that are necessary for new tire purchases as well as the repairs and recapping to run concurrently, this department is seeking an extension to this bid until December 31, 2023. The current vendor for these services, Sullivan Tire, has agreed to this extension. Therefore, this request is to increase the awarded amount by \$35,000.00 with the current vendor, Sullivan Tire.

Please consider this memo a request for Sec. 6-12, alteration to contract, of the City Charter to increase the cap from \$280,000 to \$315,000 an increase of \$35,000, and extend the expiration from September 7, 2023 to December 31, 2023.

(65-318 - \$35,000)

Moretti Christy L

From: Jay Haughey <jay.haughey@sullivantire.com>
Sent: Monday, June 26, 2023 8:27 AM
To: Moretti Christy L
Cc: Bill Morris; Robert Fagan
Subject: [EXT] - FW: [EXT] Warwick RI Retread Price Assistance

Caution! This message was sent from outside your organization.

Good morning,

We were successful in getting an extension for retreading until 12/31/2023. I will also have the labor prices extended.

Respectfully,

Jay Haughey

Senior Territory Sales Representative
Cell# 508-509-0219



From: Mark Fogel <mark.fogel@sullivantire.com>
Sent: Friday, June 23, 2023 12:17 PM
To: Jay Haughey <jay.haughey@sullivantire.com>
Cc: Dept: National Accounts <national.accounts@sullivantire.com>; Dept: Credit <credit@sullivantire.com>; David Bradley <david.bradley@sullivantire.com>; Mark Day <mark.day@sullivantire.com>; Matthew Rubino <matthew.rubino@sullivantire.com>; Larry Farrell <larry.farrell@sullivantire.com>
Subject: FW: [EXT] Warwick RI Retread Price Assistance

Good Afternoon,

Retread Assistance for Warwick RI has been extended through 12/31/2023 for Bid 2022-108.

PRICE BOOK / CONTRACT #:

SUPPLY POINT ID:

241245

AGENCY:

AGENCY BID #:

City of Warwick

2022-108

DATE DUE:

CONTRACT START:

08/03/2021

09/08/2021

SUBMITTED BY-NAME:

SUBMITTED BY-PHONE #:

Mark Fogel

5084080659

CREATED BY:

mark.fogel@sullivantire.com

Mark Fogel

Inventory Audit Supervisor

SULLIVAN TIRE
AND AUTO SERVICE

Tel: (508) 659-2298

Fax: (508) 659-2432

mark.fogel@sullivantire.com**From:** McKinney, Linda <McKinneyLinda@BFUSA.COM>**Sent:** Friday, June 23, 2023 12:05 PM**To:** Mark Fogel <mark.fogel@sullivantire.com>**Subject:** RE: [EXT] Warwick RI Retread Price Assistance

CAUTION: mckinneylinda@bfusa.com is an external email and was **NOT** sent by Sullivan Tire. Please think before clicking on any links or attachments.

Mark,

We were able to extend to 12/31/2023.

*Linda McKinney*

Government Sales Operations Analyst

B2B Government Sales

Consumer Tires Sales Division

Bridgestone Americas, Inc.

Office: (615) 937-3186

Web | [Twitter](#) | [Facebook](#) | [Instagram](#) | [LinkedIn](#)

From: Mark Fogel <mark.fogel@sullivantire.com>
Sent: Friday, June 23, 2023 8:41 AM
To: McKinney, Linda <McKinneyLinda@BFUSA.COM>
Subject: FW: [EXT] Warwick RI Retread Price Assistance
Importance: High

Good Morning Linda,

The City of Warwick RI has requested a 3 month extension for Bid 2022-108 which is set to expire on 9/7/23. Would it be possible to extend the current Retread Assistance through 12/31/2023 for this bid?

9278	241245	SULLIVAN TIRE	City of Warwick	2022-11
REQUEST TYPE: RETREAD PRICE ASSISTANCE				REQUE

PRICE BOOK / CONTRACT #:

SUPPLY POINT ID:

241245

AGENCY:

AGENCY BID #:

City of Warwick

2022-108

DATE DUE:

CONTRACT START:

08/03/2021

09/08/2021

SUBMITTED BY-NAME:

SUBMITTED BY-PHONE #:

Mark Fogel

5084080659

CREATED BY:

mark.fogel@sullivantire.com

Thanks,

Mark Fogel

Inventory Audit Supervisor

SULLIVAN TIRE
AND AUTO SERVICE

Tel: (508) 659-2298

Fax: (508) 659-2432

mark.fogel@sullivantire.com

From: Jay Haughey <jay.haughey@sullivantire.com>

Sent: Thursday, June 22, 2023 12:13 PM

To: Mark Fogel <mark.fogel@sullivantire.com>; Chelsey Belcher <chelsey.belcher@sullivantire.com>

Cc: David Bradley <david.bradley@sullivantire.com>; Mark Day <mark.day@sullivantire.com>; Matthew Rubino <matthew.rubino@sullivantire.com>; Larry Farrell <larry.farrell@sullivantire.com>

Subject: RE: [EXT] Warwick RI Retread Price Assistance

Importance: High

Hi Mark,

City of Warwick is requesting a bid extension until 12/31/2023 for retreading. Can we please ask for a 3 month extension?

Respectfully,

Jay Haughey

Senior Territory Sales Representative

Cell# 508-509-0219



Mark Fogel
Inventory Audit Supervisor

Jay Haughey
Senior Territory Sales Representative

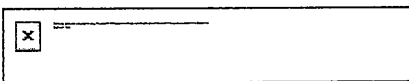

151 Charles F Colton Rd. Taunton, MA 02780
tel (508) 408-0608 , fax (508) 408-0689

CITY OF WARWICK
 STATE OF RHODE ISLAND
 RESOLUTION OF THE CITY COUNCIL

8/30/2021

MEETING DATE: _____

R-21-104

NO: _____

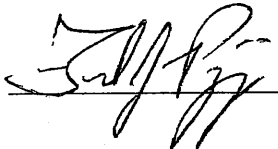
APPROVED:  _____ MAYOR

DATE: 9-2-21 _____

RESOLVED, That The City Council of the City of Warwick as required by the provisions of Sections 6-11 and 6-12 of the City Charter and the Ordinance relative to competitive bidding on purchase enacted there under hereby and herewith approves the acceptance of the following bid(s):

Bid #	Name	Vendor(s) Name/Address	Contract Award	Contract Period	Note	Code
2022 - 108	Tire Repairs & Recapping	<i>Sullivan Tire Co., Inc.</i> 1199 Jefferson Blvd. Warwick, RI 02886	\$280,000.00	9/8/21 - 9/7/23		
2022 - 106	Purchase Bulk Road Salt	<i>Mid-American Salt, LLC</i> 4528 Hillegas Road Fort Wayne, IN 46818	\$150,000.00	10/29/21 - 10/28/22		



Continued next page

Bid #	Name	Vendor(s) Name/Address	Contract Award	Contract Period	Note	Code
2022 - 102A	Asphalt Concrete Hot Mixes & Cold Patch	<p><i>Lynch Corp.</i> 50 Lynch Place Cumberland, RI 02864</p> <p><i>Narragansett Improvement Co.</i> 223 Allens Ave. Providence, RI 02903</p> <p><i>Material Sand & Stone Corp.</i> 618 Greenville Road North Smithfield, RI 02896</p> <p><i>Johnston Asphalt, LLC</i> 100 Allendale Ave. Johnston, RI 02919</p> <p><i>Cardi Corporation</i> 400 Lincoln Ave. Warwick, RI 02888</p> <p><i>D'Ambra Construction Co., Inc.</i> 80 Centre of N.E. Blvd. Coventry, RI 02816</p>	\$160,000.00 DPW	9/15/21 - 9/14/22		
2022 - 102B	Asphalt Concrete Hot Mixes & Cold Patch	<p><i>Lynch Corp.</i> 50 Lynch Place Cumberland, RI 02864</p> <p><i>Narragansett Improvement Co.</i> 223 Allens Ave. Providence, RI 02903</p> <p><i>Material Sand & Stone Corp.</i> 618 Greenville Road North Smithfield, RI 02896</p> <p><i>Johnston Asphalt, LLC</i> 100 Allendale Ave. Johnston, RI 02919</p> <p><i>Cardi Corporation</i> 400 Lincoln Ave. Warwick, RI 02888</p> <p><i>D'Ambra Construction Co., Inc.</i> 80 Centre of N.E. Blvd. Coventry, RI 02816</p>	\$65,000.00 WATER	9/15/21 - 9/14/22		

Continued next page

PCR-112-21 (Sub A)

Bid #	Name	Vendor(s) Name/Address	Contract Award	Contract Period	Note	Code
2022 - 142	Purchase Taser CEW and Associated Equipment	<i>Axon Enterprise, Inc.</i> 17800 N 85 th St. Scottsdale, Arizona 85255	\$154,688.00	10/1/21 - 9/30/26		56 - 6
2022 - 144	Website Hosting & Support	<i>Civic Plus</i> 302 S 4 th Street Suite 500 Manhattan, KS 66502	\$4,725.00	10/1/21 - 9/30/22		56 - 6
2021 - 118	Medical Examinations- Police	<i>University of Rhode Island Student Loan Office Roosevelt Hall, Suite 018B</i> 90 Lower College Rd. Kingston, RI 02881	\$525.00		1	6 - 12
2022 - 093	Police Promotional Testing	<i>ID #10</i>	\$24,000.00	9/27/21 - 9/26/23		
2022 - 116	Fire Department Dress Uniforms, Badges, Insignias & Name Plates	<i>Donnelly's Inc. of Rhode Island</i> 50 Sharpe Dr. Cranston, RI 02920	\$15,000.00	Two years from date of award		
2022 - 143	Purchase Carts, Wheels, & Lids	<i>Rehrig Pacific</i> 1738 W 20 th Street Erie, PA 16502	\$42,428.00			56 - 6
2022 - 107	Professional Printing and Mailing of Recycling Calendar	<i>Indiana Printing & Publishing Company, Inc.</i> 775 Indian Springs Road Indiana, PA 15701	\$30,000.00			

Continued next page

Bid #	Name	Vendor(s) Name/Address	Contract Award	Contract Period	Note	Code
2022 - 100	Infield Mix	<i>Richmond Sand and Stone, LLC</i> 35 Stilson Road Richmond, RI 02898	\$14,000.00	9/9/21 - 9/8/23		
2022 - 148	Remove & Replace Pilgrim Senior Center Dishwasher	<i>United Restaurant Equipment Co.</i> 1 Executive Park Dr. North Billerica, MA 01862	\$13,600.00			56 - 6

AND BE IT FURTHER RESOLVED, That such purchase or contract be awarded to the lowest responsible bidder.

1. Request permission to increase PCR-71-20 from \$8,400.00 to \$8,925.00

Actions Taken:

Bid2021-236 Emergency Equipment Repair for Police Vehicles **PCR-113-21 (Sub A)**
Increase award by
\$7,000.00

Bid2022-067 Workers' Compensation Self-Insured Third-Party Administrator or Fully-Insured Carrier **PCR-114-21**
Favorable Action

THIS RESOLUTION SHALL TAKE EFFECT UPON ITS PASSAGE

Bid2022-108 Tire Repairs & Recapping

COPY

- 1 bid received

CODE: 65-318 Automotive/Tire Recapping

MANNER OF AWARD: \$280,000.00
September 8, 2021 – September 7, 2023

RECOMMEND: Sullivan Tire Co., Inc.

Sullivan Tire Co., Inc.
1199 Jefferson Blvd.
Warwick, RI 02886

Pricing as follows

Continued next page

**Bid2022-108 Tire Repairs & Recapping
RESULTS**

COPY

Item #	Description	Normal Working Hours 7:00 AM – 4:30 PM	Weekends and Holidays 4:30 PM – 7:00 AM
1.	<u>PAYLOADERS</u>		
a.	Remove	\$25.00	\$25.00
b.	Apply	\$25.00	\$25.00
c.	Tire Repair*	\$50.00	\$50.00
d.	Tube Repair*	\$10.00	\$10.00
2.	<u>BACKHOES</u>		
a.	Remove	\$20.00	\$20.00
b.	Apply	\$20.00	\$20.00
c.	Tire Repair*	\$40.00	\$40.00
d.	Tube Repair*	\$20.00	\$20.00
3.	<u>PACKERS</u>		
a.	Remove	\$15.00	\$15.00
b.	Apply	\$15.00	\$15.00
c.	Tire Repair*	\$30.00	\$30.00
d.	Tube Repair*	\$10.00	\$10.00
4.	<u>DUMP TRUCKS</u>		
a.	Remove	\$15.00	\$15.00
b.	Apply	\$15.00	\$15.00
c.	Tire Repair*	\$30.00	\$30.00
d.	Tube Repair*	\$10.00	\$10.00
5.	<u>PICKUP TRUCKS</u>		
a.	Remove	\$10.00	\$10.00
b.	Apply	\$10.00	\$10.00
c.	Tire Repair*	\$25.00	\$25.00
d.	Tube Repair*	\$10.00	\$10.00
6.	<u>FIRE VEHICLES</u>		
a.	Remove	\$15.00	\$15.00
b.	Apply	\$15.00	\$15.00
c.	Tire Repair*	\$30.00	\$30.00
d.	Tube Repair*	\$10.00	\$10.00
7.	<u>OTHER VEHICLES</u>		
a.	Remove	\$10.00	\$10.00
b.	Apply	\$10.00	\$10.00
c.	Tire Repair*	\$20.00	\$20.00
d.	Tube Repair*	\$10.00	\$10.00
	Charge for calcium chloride, per pound, installed in DPW vehicle tires	\$7.00/lb.	\$7.00/lb.
	Charge for road service or service call to Department of Public Works for Truck Service	\$100.00/hr.	\$125.00/hr.
	Charge for road service or service call to Department of Public Works for OTR tires	\$110.00/hr.	\$140.00/hr.

Continued next page

**Bid2022-108 Tire Repairs & Recapping
RESULTS**

COPY

Item #	Description	Price
	Sander/Dump Trucks	
1	11R22.5 Bandag Ultra Drive	\$183.00
2	12R22.5 Bandag Ultra Drive	\$195.00
	Sanders, Dump & Fire Trucks	
3	11R22.5 Bandag Ultra Drive (steel belted casings)	\$183.00
4	12R22.5 Bandag Ultra Drive (steel belted casings)	\$195.00
	Dump & Fire Trucks	
5	11R22.5 Bandag Ultra Drive (steel belted casings)	\$183.00
6	12R22.5 Bandag Ultra Drive (steel belted casings)	\$195.00
	Highway/Fire/Water Trucks	
7	12R22.5 Bandag Ultra Drive	\$195.00
8	11R24.5 Bandag Winter Deep	\$190.00
	Sanitation/Recycling Truck	
9	11R24.5 Bandag Ultra Drive	\$194.00
10	11R22.5 Bandag Ultra Drive	\$183.00
	<u>Repairs in casings for re-treads</u>	
	N-hole	\$5.00
	Spot	\$12.00
	Section	\$40.00

VENDORS DEPT VERIFIED Tires-Tire Recapping

Bid2022-108 Tire Repairs & Recapping							
The following vendors were sent specifications							
	VENDOR	ADDRESS	CITY	STATE	ZIP	EMAIL	
1	CB Truck Tire Service	140 Farmington Rd	Cranston	RJ	02920	Anthony@ostire.necoxmail.com;	
2	Ocean State Tire Co., Inc.	51 Worthington Rd./PO Box 8062	Cranston	RJ	02920	paul@ostire.necoxmail.com	
7	Pete's Tire Barn	80 Public St.	Providence	RJ	02903	frankandreoizzi@petestire.com;stevejones@petestire.com; info@petestire.com	
	Sullivan Tire	1199 Jefferson Blvd.	Warwick	RJ	02886	Jay.haughey@sullivantire.com;mark.fogel@sullivantire.com;mark.day@sullivantire.com	

COPY



CITY OF WARWICK
DEPARTMENT OF PUBLIC WORKS
925 SANDY LANE • WARWICK, RHODE ISLAND 02889
TEL (401) 738-2003 • FAX (401) 732-5208

COPY
AUG 12 2021

FRANK J. PICOZZI
MAYOR

ERIC J. EARLS, PE
DIRECTOR OF PUBLIC WORKS

To: Patricia Peshka, Purchasing Agent

From: Eric J. Earls, Director of Public Works *EE*

Date: August 11, 2021

Subj: Bid2022-108 Tire Repair and Recapping

This department has reviewed the only bid submitted on the above and recommends award to Sullivan Tire Co., Inc. for the repair and recapping of tires for City vehicles under the purview of the Department of Public Works.

The recommended cap is \$280,000.00 for a two-year period. This bid currently expires on September 7, 2021. The new contract period will be September 8, 2021 to September 7, 2023.

(65-318 - \$280,000)

CODE: 14-203 Probate Court - Advertising

SECTION 56-6

Bid2024-087 Probate Court Advertising

Beacon Communications
1944 Warwick Ave.
Warwick, RI 02889

Kent County Daily Times
PO Box 277
West Warwick, RI 02893

Contract Award: \$30,000.00

Contract Period: July 1, 2023 – June 30, 2024



JUN 13 2023
CITY OF WARWICK
OFFICE OF THE CITY CLERK
3275 POST ROAD
WARWICK, RHODE ISLAND 02886
TEL. (401) 738-2000
FAX (401) 732-7640

Frank J. Picozzi
MAYOR

Lynn D'Abrosca
City Clerk

To: Francis Gomez – Purchasing Agent
From: Lynn D'Abrosca – City Clerk
Date: June 9, 2023
RE: 56-6 EXCEPTION TO PUBLICATION – Probate Court Advertising

I am requesting that the City Council award the advertising of Probate Court matters to the Warwick Beacon and the Kent County Daily Times. Probate Court is required to advertise their hearings in a newspaper with "countywide circulation". Placing the ads in both newspapers would cover the entire county, as well as save the petitioners advertising fees.

The budget amount is \$30,000, in which each publication is designated \$15,000 for these expenses. This will be a drawdown to code 14-203 for fiscal year 2023-2024. These fees are paid by the petitioners and the revenue will appear in budget code 14-929.

If you have any questions, I can be reached at ext. 9561.

Note: This bid is for FY 2024 - 7-1-2023 through 6-30-2024, the funds will be in the FY2024 Budget Under City Clerk's Commodities 14-203. The current bid expires 6/30/23

Bid 2024-079 Repair & Rebuild Hydraulic Cylinders

- 1 bid received

CODE: 65-314 Automotive – Equipment Repair

MANNER OF AWARD: \$25,000.00
8/26/2023 – 8/25/2024

RECOMMEND: Tri-Power Sales & Service, Inc.

Tri-Power Sales & Service, Inc.
64 Minnesota Ave.
Warwick, RI 02888

Description	Bid
Mechanic rate/hr.	\$80.00
Welding rate/hr.	\$80.00
Machine rate/hr.	\$80.00
Miscellaneous rate/hr.	\$80.00

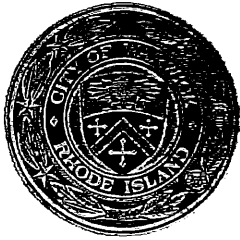

CITY OF WARWICK
DEPARTMENT OF PUBLIC WORKS
925 SANDY LANE • WARWICK, RHODE ISLAND 02889
TEL (401) 738-2003 • FAX (401) 732-5208

JUN 29 2023

FRANK J. PICOZZI
MAYOR

ERIC J. EARLS, PE
DIRECTOR OF PUBLIC WORKS

To: Francis Gomez, Purchasing Agent

From: Eric J. Earls, Public Works Director *EJE*

Date: June 29, 2023

Subj: Bid2024-079 Repair and Rebuilding Hydraulic Cylinders

We have reviewed the only bid submitted for the above and recommend award to Tri Power Sales and Service, Inc. as the qualified vendor for the above related services.

The current bid expires on August 25, 2023. The new contract period will be August 26, 2023 to August 25, 2024. The recommended cap is \$25,000.00 for a one-year period.

(65-314- \$25,000)

Tri-Power Sales

PLEASE COMPLETE THIS PAGE & SUBMIT WITH YOUR BID

The list below is a sample of parts that may be required for repairs and/or rebuild of any cylinders. Percentage off must be held firm for the term of the contract.

Description	Last price	Percentage off	Net Price	
AY2-342	2.75	20%	2.20	
AY8-342	2.73	/	2.18	
AYAS900E-64	25.80		20.64	
AYU-2500	6.08		4.86	
AY25001500-375	11.07		8.85	
AY18701250-312B	7.32		5.85	
CH1.250	2.96/in		0	2.96/in
AYG109094	7.05		20%	5.64
AYU-1750	5.00		/	4.00
AYPSP-338	28.85			23.08
4X1/2WB	6.60			5.28
1211175175	-	-	-	
AYAS900E-48	15.35	20%	12.28	
GTG60144-0202	12.92	50%	6.46	
AYSP	-	-	-	
AY940-1	3.54	20%	2.83	
AYBS-18701250-312	10.20	/	8.16	
AYPSP-330	21.02		16.81	
AYU-1000	3.50		2.80	
AYME1000HJ-P	9.28		7.42	
AY2-326	1.40		1.12	

Percentage off parts not listed above % 0-50% depending on manufacturer

VENDORS Repair Rebuild Hydraulic Cylinders

Bid2024-079 Repair/Rebuild Hydraulic Cylinders						
The following vendors were sent specifications						
VENDOR	ADDRESS	CITY	STATE	ZIP	EMAIL	
Brookline Machine Company Dba/Cockcroft Co.	333 Waterman Ave	East Providence	RJ	02914	send USPS	
Dene Hydraulics, Inc.	179 Gallivan Rd.	Uncasville	CT	06382	brian@dhilt.com; sales@dhict.com	
C & C Hydraulics & Lubrication	116 Wolcott Rd.	Terryville	CT	06786	charles@cchydraulics.com; sales@cchydraulics.com	
NH Hydraulics, Inc.	Three Columbia Circle	Merrimack	NH	03054	thavatzes@nh-hydraulics.com; Sales@NH-Hydraulics.com	
Tri-Power Sales & Service	64 Minnesota Ave.	Warwick	RJ	02889	b.davis@tripowersales.com; djdavis@tripowersales.com	

CODE: 76-357 Insurance – Insured Accidents General

SECTION 56-6

**Bid2024-102 Repair Two Light Fixtures from Motor Vehicle
Accidents**

Arden Engineering Constructors LLC
505 Narragansett Park Drive
Pawtucket, RI 02861

Contract Award: \$21,788.00

Contract Period: One Time Purchase



CITY OF WARWICK
DEPARTMENT OF PUBLIC WORKS
925 SANDY LANE • WARWICK, RHODE ISLAND 02889
TEL (401) 738-2003 • FAX (401) 732-5208

FRANK J. PICOZZI
MAYOR

ERIC J. EARLS, PE
DIRECTOR OF PUBLIC WORKS

JUN 28 2023

To: Francis Gomez, Purchasing Agent
From: Eric J. Earls, Director of Public Works
Date: June 26, 2023
Subj: Arden Engineering Constructors, LLC

This department has requested quotes from the above named vendor for replacement fixtures at two different locations due to traffic accidents. The accident on October 21, 2021 was the fault of an uninsured driver and will be covered by the RI Interlocal Risk Trust. The fixture that was damaged is a decorative light pole on the Coronado bridge. The City must make the repairs, submit documentation to the Trust of the same and will be reimbursed the cost of \$16,153.00.

On May 24, 2023, the second accident involved two vehicles in which one of the vehicles hit and knocked down a pedestrian crossing fixture at Williamsburg Drive and Jefferson Boulevard, requiring replacement. This department has notified the driver's insurance of the cost to replace the unit and is awaiting reimbursement funds of \$5,635.00. However, as this is a pedestrian safety crossing on a four lane roadway, this department is requesting to have it replaced as soon as possible.

Please consider this memo a request for an exception to notice under Sec. 56-6 of the Warwick Code for Arden Engineering Constructors, LLC to perform the services as quoted for each location. The total cost for installing both of these replacement fixtures is \$21,788.00

(76-357 - \$21,788.00)



Arden Engineering Constructors, LLC
505 Narragansett Park Drive
Pawtucket, RI 02861
Phone (401) 727-3500
Fax: (401) 727-3540

June 22, 2023

City Of Warwick
3275 Post Rd
Warwick, RI 02886

Site Address:
Same

Attention: Robert Greenway
Project Name: Coronado Rd Bridge Decorative Pole & Fixture

Arden is pleased to present you with a proposal to furnish and install a new Decorative light pole as described below:

Scope:

- Remove existing foundation with failed anchor bolts
- Pour new foundation with anchor bolts
- Furnish and install decorative pole
- Furnish and install new decorative fixture
- Install new wire in existing conduit

Price.....\$16,153.00

Notes/Clarifications/Exclusions:

1. Taxes are excluded and will be added to the invoice, if applicable
2. Any service not listed is excluded
3. Arden assumes existing conduit is in good condition to run new wire
4. Replacement of any conduit outside the foundation is excluded
5. Work is quoted as being performed during normal business hours
6. Additional terms and conditions, below are made part of this proposal

Ryan Doyle
Arden Engineering Constructors, LLC

This proposal is valid 30 days from May June 22, 2023
This agreement is subject to the attached Terms and Conditions.

CUSTOMER ACCEPTANCE

Arden Engineering Constructors, LLC

Authorized Representative

Authorized Representative

Title

Title

Acceptance Date

Signature Date



Arden Engineering Constructors, LLC
505 Narragansett Park Drive
Pawtucket, RI 02861
Phone (401) 727-3500
Fax: (401) 727-3540

June 22, 2023

City Of Warwick
3275 Post Rd
Warwick, RI 02886

Site Address:
Same

Attention: Robert Greenway
Project Name: Jefferson Blvd @ Williamsburg Dr Pedestrian Signal

Arden is pleased to present you with a proposal to replace the Pedestrian signal at the above reference location as described below:

Scope:

- Remove existing foundation with failed anchor bolts
- Furnish and install new foundation
- Furnish and install new Ped signal pole/base
- Furnish and install (2) new Pedestrian signals
- Furnish and install (2) new Pedestrian push buttons
- Rewire and test for proper operation

Price.....\$5,635.00

Notes/Clarifications/Exclusions:

1. Taxes are excluded and will be added to the invoice, if applicable
2. Any service not listed is excluded
3. Arden assumes existing conduit is in good condition to run new wire
4. Work is quoted as being performed during normal business hours
5. Additional terms and conditions, below are made part of this proposal

Ryan Doyle
Arden Engineering Constructors, LLC

This proposal is ~~valid 30 days~~ from May June 22, 2023
This agreement is subject to the attached Terms and Conditions.

CUSTOMER ACCEPTANCE

Arden Engineering Constructors, LLC

Authorized Representative

Authorized Representative

Title

Title

Acceptance Date

Signature Date

Bid2024-067 Fire Apparatus Annual Pump Testing & Service

- 1 bid received

CODE: 35-330 Fire Department – Auto & Vehicle Maintenance

MANNER OF AWARD: \$20,000.00
9/21/2023 – 9/20/2025

RECOMMEND: On Scene, LLC

On Scene, LLC
52 West Reservoir Rd. Unit 4
Smithfield, RI 02917

Item #	Description	Price First Year	Price Second Year
1	Fire Apparatus Pump Performance Testing cost per apparatus	\$525.00	\$525.00
2	Additional Fees Fire Apparatus Pump Performance Testing	\$70.00 (additional fee is charged on any pumps over 1500 GPM)	\$70.00 (additional fee is charged on any pumps over 1500 GPM)
3	Fire Apparatus Pump Inspection & Maintenance Service cost per apparatus	\$725.00	\$725.00
4	Additional Fees Fire Apparatus Pump Inspection & Maintenance Service	N/A	N/A



Jason Umbenhauer
Assistant Chief

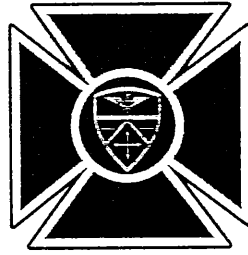

Office: (401) 468-4044
Fax: (401) 468-4043

Warwick Fire Department
111 Veterans Memorial Drive
Warwick, Rhode Island 02886

June 28, 2023

Francis Gomez
Purchasing Agent
City of Warwick

The bid for *Fire Apparatus Annual Pump Testing & Service, Bid#2024-067* has been carefully reviewed by the Fire Department.

One (1) vendor submitted a bid, and after evaluating pricing the following vendor has fully satisfied the specifications outlined in our request. Therefore, I recommend the bid be awarded to the following vendor:

On Scene, LLC, Smithfield, RI

Services included in the bid will provide the required Fire Apparatus Pump Performance Testing and Pump Inspection and Maintenance Service in accordance with NFPA 1911.

The current bid expires 9/20/2023 and the Fire Department is requesting a two (2) year bid award for an total amount not to exceed \$20,000. Funding for this product will be from budget code 35-330 Auto & Vehicle Maintenance.

Please contact me should you have any questions.

Jason Umbenhauer
Assistant Chief

Bid2024-067 Fire Apparatus Annual Pump Testing & Service						
The following vendors were sent specifications						
VENDOR	ADDRESS	CITY	STATE	ZIP	EMAILS	
Fire One, Inc.	PO Box 1040	Drexel Hill	PA	19026	jimglatts@fire-one.com; fireone@mistrasgroup.com	
Fire Dept. of Hartford dba Five Star Fire	45 Brainard Road	Hartford	CT	06114	rarnott@five-star-fire.com	
Greenwood Emergency Vehicles	530 John Dietsch Blvd.	Attleboro	MA	02760	wcoady@greenwoodev.com; cboutin@greenwoodev.com; sales@greenwoodev.com	
On Scene, LLC	5600 Post Rd, Suite 114-324	East Greenwich	RI	02818	scheduling@onsceneservice.com	
Shipman's Fire Equipment Co., Inc.	172 Cross Rd. PO Box 257	Waterford	CT	06385	jfarr@shipmans.com; tbaker@shipmans.com	
Specialty Vehicles Inc.	18 Commerce St	Plainville	MA	02762	cberlo@svine.com	

Bid2024-070 Fire Department Dress Uniforms, Badges, and Accessories

- 3 bids received

CODE: 35-260 Fire Department – Clothing

MANNER OF AWARD: \$20,000.00
9/20/2023 – 9/19/2025

RECOMMEND: Stillman Uniforms & Donnelly's Inc. of RI

Jonah's Enterprises Inc.
652 Lefferts Ave.
Brooklyn, NY 11203

Stillman Uniforms
271 Post Road E-1
Westerly, RI 02891

Donnelly's Inc. of RI
50 Sharpe Dr.
Cranston, RI 02920

Pricing as Follows



Jason Umbenhauer
Assistant Chief

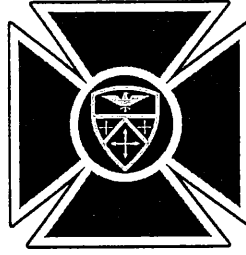

Office: (401) 468-4044
Fax: (401) 468-4043

Warwick Fire Department
111 Veterans Memorial Drive
Warwick, Rhode Island 02886

June 28, 2023

Francis Gomez
Purchasing Agent
City of Warwick

The bid for *Fire Department Dress Uniforms, Badges & Accessories, Bid#2024-070* has been carefully reviewed by the Fire Department.

Three (3) vendors submitted bids, and after evaluating the submissions, the following vendor has met all the specifications without exception. The Fire Department is recommending the bid be awarded to the following vendors:

Donnelly's Inc. of Rhode Island, Cranston, RI

Stillman Uniforms, Westerly, RI

The Fire Department will be utilizing the lowest cost vendor for the Class A uniforms and accessories. Donnelly's Inc. bid the most aggressive discount for badges and will be utilized for those specific orders.

The Department is not recommending Jonah's Enterprises due to their stated minimum requirement of 24 employees per fitting session. The Fire Department requires these fitting on an as needed basis and rarely requires 24 fitting throughout the entire year.

The current bid expires on 9/19/2023 and if approved, the department is requesting a two (2) year award, for an amount not to exceed \$20,000. Funding for this product will be from budget code 35-260 Clothing.

Please contact me should you have any questions.

Jason Umbenhauer
Assistant Chief

2024-070 Fire Department Dress Uniforms, Badges, and Accessories BID RESULTS

Jonah's Enterprises (1)				
Item #	Description	Brand, Style, and Product Number	Price Year 1	Price Year 2
1	Blouse Coat			
a	Chief of Department	Elbeco 13750	\$ 264.78	\$ 291.26
b	Assitant Chief	Elbeco 13750	\$ 264.78	\$ 291.26
c	Deputy Chief	Elbeco 13750	\$ 264.78	\$ 291.26
d	Battalion Chief	Elbeco 13750	\$ 264.78	\$ 291.26
e	Lieutenant/Captain	Elbeco 13750	\$ 264.78	\$ 291.26
f	Private	Elbeco 13750	\$ 267.26	\$ 293.98
2	Dress Trousers	Elbeco E1360RN	\$ 111.65	\$ 122.81
3	Blue Uniform Hat			
a	Lieutenant/Captain	Keystone R8-149-800-SFD	\$ 81.00	\$ 89.10
b	Private	Keystone R8-149-800-SFD	\$ 81.00	\$ 89.10
4	White Uniform Hat			
a	Chief & Assistant Chief	Keystone R8-149-800-SFD	\$ 81.00	\$ 89.10
b	Deputy Chief	Keystone R8-149-800-SFD	\$ 81.00	\$ 89.10
	Battalion Chief	Keystone R8A-140-800-SFD	\$ 81.00	\$ 89.10
5	Uniform Tie	Samuel Browne & Company 90051	\$ 5.36	\$ 5.89
6	White Uniform Gloves	Samuel Browne & Company 99058-WHT-XL	\$ 5.39	\$ 5.93
		% Discount off Smith & Warren Website Price at Time of Order	Year 1	Year 2
7	Breast Badge Smith & Warren		10%	10%
8	Hat Badge Smith & Warren		10%	10%
9	Collar Insignia Smith & Warren		10%	10%
10	Name Plate Smith & Warren		10%	10%
Notes:				
1. Terms of Fitting: Minimum of 24 Employees per fitting. No more than 2 fittings per season.				
2. Collar Insignia ELC Brand Gold & Silver Year 1 \$10.95 Year 2 \$11.95				
3. Name Plate Reeves Gold or Silver Year 1 \$16.95 Year 2 \$18.95				
4. Price Increases for Coats & Matching Trousers: 10% for sizes 48-50, 20% for sizes 52-54, 30% for size 56				
5. Price increase for ties: add \$0.25 for longer than 60" tie when needed				

2024-070 Fire Department Dress Uniforms, Badges, and Accessories BID RESULTS

Item #	Description	Stillman Uniforms (see notes 2 & 3)		
		Brand, Style, and Product Number	Price Year 1	Price Year 2
1	Blouse Coat			
a	Chief of Department		\$ 310.00	\$ 322.00
b	Assitant Chief		\$ 298.00	\$ 310.00
c	Deputy Chief		\$ 286.00	\$ 298.00
d	Battalion Chief		\$ 274.00	\$ 285.00
e	Lieutenant/Captain		\$ 274.00	\$ 285.00
f	Private		\$ 240.00	\$ 252.00
2	Dress Trousers		\$ 110.00	\$ 115.00
3	Blue Uniform Hat			
a	Lieutenant/Captain		\$ 75.00	\$ 78.00
b	Private		\$ 60.00	\$ 62.00
4	White Uniform Hat			
a	Chief & Assistant Chief		\$ 120.00	\$ 125.00
b	Deputy Chief		\$ 120.00	\$ 125.00
	Battalion Chief		\$ 80.00	\$ 82.00
5	Uniform Tie		\$ 9.95	\$ 10.00
6	White Uniform Gloves		\$ 4.00	\$ 4.50
		% Discount off Smith & Warren Website Price at Time of Order	Year 1	Year 2
7	Breast Badge Smith & Warren		12%	12%
8	Hat Badge Smith & Warren		12%	12%
9	Collar Insignia Smith & Warren		Exception 2	Exception 2
10	Name Plate Smith & Warren		Exception 3	Exception 3

2024-070 Fire Department Dress Uniforms, Badges, and Accessories BID RESULTS

		Donnelly's (see notes 4 & 5)		
Item #	Description	Brand, Style, and Product Number	Price Year 1	Price Year 2
1	Blouse Coat			
	a Chief of Department	Elbeco 13756	\$ 354.20	\$ 366.60
	b Assitant Chief	Elbeco 13755	\$ 336.40	\$ 348.20
	c Deputy Chief	Elbeco 13755	\$ 322.40	\$ 333.70
	d Battalion Chief	Elbeco 13755	\$ 308.40	\$ 319.20
	e Lieutenant/Captain	Elbeco 13754	\$271.00/Capt. \$257.00/Lieut.	\$280.50/Capt. \$266.00/Lieut.
	f Private	Elbeco 1370	\$ 213.80	\$ 221.30
2	Dress Trousers	Elbeco E1360RN	\$ 105.80	\$ 109.60
3	Blue Uniform Hat			
	a Lieutenant/Captain	Keystone R-8 Bell	\$ 84.70	\$ 87.70
	b Private	Keystone R-8 Bell	\$ 69.30	\$ 71.80
4	White Uniform Hat			
	a Chief & Assistant Chief	Keystone R8 Fire Bell	\$ 123.10	\$ 127.50
	b Deputy Chief	Keystone R8 Fire Bell	\$ 123.10	\$ 127.50
	Battalion Chief	Keystone R8 Fire Bell	\$ 84.70	\$ 87.70
5	Uniform Tie	Samuel Broome 90078-57	\$ 5.70	\$ 5.90
6	White Uniform Gloves	Samuel Broome 99055	\$ 5.40	\$ 5.60
		% Discount off Smith & Warren Website Price at Time of Order	Year 1	Year 2
7	Breast Badge Smith & Warren		22%	22%
8	Hat Badge Smith & Warren		22%	22%
9	Collar Insignia Smith & Warren		22%	22%
10	Name Plate Smith & Warren		22%	22%

Bid2024-070 Fire Department Dress Uniforms, Badges, and Accessories						
The following vendors were sent specifications						
VENDOR	ADDRESS	CITY	STATE	ZIP	EMAILS	
9 ERP	175 Bethpage Sweet Hollow Road	Old Bethpage	NY	11804	customerservice@911erp.com	
Ahchortex Corporation	420 Commerce Lane	West Berlin	NJ	08091	info@anchortex.com	
Barney's Uniform Caps	922 Cranston St	Cranston	RI	02920		
Donnelly's of Rhode Island	50 Sharpe Drive	Cranston	RI	02920	pcd@donnellysclothing.com	
Leader Uniforms	365 Broadway	Providence	RI	02909		
Rhode Island Uniform & Supply	1395 Atwood Ave #109	Johnston	RI	02919	scot@riuniform.com	
Stillman Uniforms	271 Post Road, Suite #1	Westerly	RI	02891	Stillmanu@verizon.net	

CODE: 13-203 Municipal Court - Advertising

SECTION 56-6

Bid2024-088 City Clerk Advertising

Beacon Communications
1944 Warwick Ave.
Warwick, RI 02889

Contract Award: \$20,000.00

Contract Period: July 1, 2023 – June 30, 2024

JUN 13 2023



CITY OF WARWICK
OFFICE OF THE CITY CLERK
3275 POST ROAD
WARWICK, RHODE ISLAND 02886
TEL. (401) 738-2000, ext. 6221
FAX (401) 738-6639
T.D.D. 739-9150

FRANK J. PICOZZI
MAYOR

Lynn D'Abrosca
City Clerk

To: Francis Gomez – Purchasing Agent
From: Lynn D'Abrosca – City Clerk
Date: June 12, 2023
RE: 56-6 EXCEPTION TO PUBLICATION – City Clerk Advertising

I am requesting an exception to publication under the City of Warwick Code of Ordinances Chapter 56-6, due to the fact that The Warwick Beacon is the sole source vendor for placing these advertisements. It would be a disadvantage for the City to bid this service.

These expenses are to advertise zone changes, abandonments and any ordinances that the City Council passes during fiscal year 2024. The code used will be 13-203. The budgeted amount is \$20,000.

If you have any questions, I can be reached at ext. 9561.

Note: This bid is for FY 2024 - 7-1-2023 through 6-30-2024, the funds will be in the FY2024 Budget under City Clerk's Commodities 13-203. The current bid expires 6/30/23

CODE: 27-340 Municipal Court – Service Contracts

SECTION 56-6

Bid2024-089 Municipal Court Software

Curia Systems, Inc.
PO Box 2031
East Greenwich, RI 02818

Contract Award: \$20,000.00

Contract Period: September 1, 2023 – August 31, 2024



CITY OF WARWICK
OFFICE OF THE CITY CLERK
3275 POST ROAD
WARWICK, RHODE ISLAND 02886
TEL. (401) 738-2000, ext. 6221
FAX (401) 738-6639
T.D.D. 739-9150

Frank J. Picozzi
MAYOR

Lynn D'Abrosca
City Clerk

JUN 13 2023

To: Francis Gomez – Purchasing Agent
From: Lynn D'Abrosca – City Clerk
Date: June 12, 2023
RE: 56-6 EXCEPTION TO PUBLICATION – Sole Source Vendor

Please consider this request for an exception to publication under 56-6 of the Warwick Code of Ordinances, as Curia Systems is a sole source vendor for this service.

The amount of \$20,000.00 covers the annual maintenance contract, support, desktop team viewer and upgrades. Curia Systems is the software used for Municipal Court. The funds are budget in account code 27-340. The current contract expires 8/31/23. The new contract period will be from 9/1/23 to 8/31/24.

If you have any questions, I can be reached at ext. 9561.

Note: This bid is for FY 2024 - 9-1-2023 through 8-31-2024, the funds will be in the FY2023 Budget under 27-340. The current bid expired 8/31/23

Daxa Arora
Curia Systems, Inc
PO BOX 2031
East Greenwich, RI, 02818

Re: Sole Source Provider

To whom it may concern:

This letter is to inform you formally that Curia Systems, Inc. is the only provided for:

1. Judicial Case Management System (JCMS Desktop and JCMS SAAS Online)
2. Curia Systems Online Payment System
3. JCMS RITT & DMV Service
4. JCMS SAAS Probate
5. JCMS Mobile Parking
6. JCMS Online Parking
7. Maintenance and Support for the above list products and services

These products and services are created, maintained, and wholly owned by Curia Systems.

Curia's product line is currently in use at 23 of the Municipal Courts in the State of Rhode Island. Curia Systems provides new enhancements and maintenance and Support for the products and services listed above. For more details on the value delivered, we would be happy to provide upon request.

Should you have any additional questions regarding our products, please do not hesitate to reach out to us!

Regards,



Daxa Arora
800-641-6608 main
800-641-6608 fax
daxa.arora@curiasystems.com
www.curiasystems.com

CODE: 35-340 Fire Department – Service Contracts
38-314 Fire Grant – RIEMA Passthrough Grants

SECTION 56-6

Bid2024-108 Multi-Gas Detection Meter Exchange Program

Industrial Scientific Corp.
One Life Way
Pittsburgh, PA 15205

Contract Award: \$20,000.00

Contract Period: One Year from Date of Award



Jason Umbenhauer
Assistant Chief

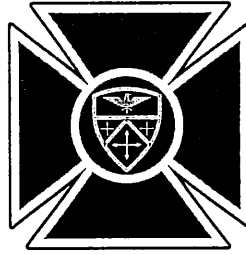

Office: (401) 468-4044
Fax: (401) 468-4043

Warwick Fire Department
111 Veterans Memorial Drive
Warwick, Rhode Island 02886

June 29, 2023

Francis Gomez
Purchasing Agent
City of Warwick

The Fire Department is seeking a 56-6 exception to bid for the purchase of an annual Multi-Gas Detection Meter Exchange Program between the City of Warwick Fire Department and Industrial Scientific Corporation of Pittsburgh, PA. Industrial Scientific terms this program the iNet Instrument Network.

For air monitoring at incidents involving Carbon Monoxide alarms, natural gas leaks, strange odors, Hazardous Material spills and releases, Technical Rescue operations, and post-fire air quality needs the department utilizes four and five gas detection meters capable of measuring toxicity and oxygen levels that poses an immediate threat to life and health. In addition, these devices are critical to monitoring explosion potential based on the upper and lower explosive ranges of many volatile gases and chemicals as result of a leak or spill. The department for 20 plus years has been utilizing Honeywell/Rae Systems multi gas detection devices utilized on the department's three Ladder Companies, Special Hazards, and Engine 10 located in Potowomet. With many of the devices currently in use over 10 years old, equipment and technology has become obsolete and prone to repeated failures resulting in extensive downtime and consistent reliability concerns. In FY23, servicing, parts, and repairs to the equipment cost the city approximately \$7,800 with an average lead of 4-6-week delivery time for replacement sensors and parts based on availability. Once parts are received, the turnaround for repairs is quick, however, if a device requires be sent out for further diagnostics and repairs that cannot be performed by department personnel, we can expect to be looking at a 4-8-week turnaround and additional repair expenses before a failed device can be put back in service.

In an effort to eliminate in house maintenance and repair responsibilities, parts and repair costs, and down time of devices, the department has found Industrial Scientific Corporation to provide the best option for updating the current inventory of multi-gas detection meters that meets department requirements through its iNet Exchange Program. Industrial Scientific's iNet Exchange subscription is a monthly subscription service that covers multi-gas detector diagnostics, repairs, shipping, and calibration gases. Industrial Scientific automatically scans devices remotely and is capable of detecting unit and sensor performance issues on any device when docked in the cloud connected calibration station specific to the device model. In the event of a device failure, a new meter is automatically shipped to the department via next day delivery to replace the failed device. Upon receipt of the new replacement device, the failed device is shipped back to Industrial Scientific at no additional cost to the city. In addition to addressing major device failures that occur without warning, routine sensor calibration and bump testing (initial performance test prior to device use for an incident) via the connected docking station enables Industrial Scientific to detect potential device issues early, triggering

Email: Jason.Umbenhauer@warwickri.gov

notification and shipment of a replacement device prior to a failure occurring in the field eliminating any down time at all. The service also affords the ability for the department to easily make changes to devices and sensor configurations based on evolving needs simply by making a request to Industrial Scientific to swap devices configured as required.

The department will maintain its current device requirement of two gas detection meters on each of the department's three (3) Ladder Companies, Special Hazards, and Engine 10. In addition to the devices kept on apparatus, two (2) devices will be utilized by the department's Hazardous Materials Team for use during hazardous materials incident mitigation configured to specifically detect highly volatile gases unitized and stored in large quantities at industrial facilities around the city.

The Department is requesting a 1-year award, for an amount not to exceed \$20,000. Funding for the request will be from the following accounts:

\$12,500 from 35-340 Service Contracts

\$7,500 from 38-814 RIEMA Passthrough Grants (100% State Reimbursed)

Industrial Scientific Corporation is the sole source provider in all markets for the proprietary iNet Instrument Network.

Please contact me should you have any questions.

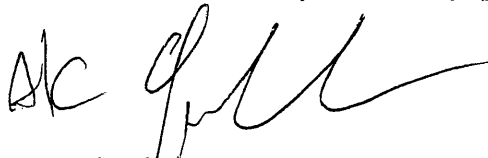

Jason Umbenhauer
Assistant Chief

Customer: Warwick Fire Department - Warwick, RI

Case #: 20230612-3977790

Date: June 12th, 2023

Expires: 60 Days

Account: New

Justin Vail
justin.d.vail@warwickri.com

iNet® Exchange Program - 12 Month Subscription

TOTAL EQUIPMENT

iNet Equipment			With AutoReplenish Plus™ (gas included)	
Qty	Part Number	Description	Price Per Month Per Unit	Total Price Per Month
5	VP5-K1BY2111111	Ventis Pro5 Personal Gas Monitor, LEL (Pentane), CO, HCN, O2 (Long-life), Li-ion Extended Run Time Battery, Desktop Charger, Pump, Orange, UL/CSA, LENS Wireless, English	141.00	705.00
6	VP5-RJYT2110111	Ventis Pro Series, PID, CO/H2S, O2 (Long Life), ULP HC IR (0-100% LEL), Li-ion Ext Range, Desktop Charger, With Integral Pump, Black, UL/CSA, LENS™ Wireless, English	108.53	651.18
1	VP5-K6732110111	Ventis Pro5 Personal Gas Monitor, LEL (Pentane), NH3, Cl2, O2, Li-ion Extended Run Time Battery, Desktop Charger, Pump, Black, UL/CSA, LENS Wireless, English	259.00	259.00
Total iNet Monthly Fee (USD)*				1,615.18

Additional cost (not included above) if you would like to have a day of training

Qty	Part Number	Description	Price Per Month Per Unit	Total Price Per Month
1	16000004	On-site advanced operational level training customized to an End User's specific needs. There is no maximum number of attendees.	435.32	435.32

Price if you would like to purchase a day of training

Qty	Part Number	Item Description	List Price	Total Price
1	16000004	On-site advanced operational level training customized to an End User's specific needs. There is no maximum number of attendees.	5,225.00	5,225.00
Total (USD)			5,225.00	

- The subscription's initial term is twelve (12) months from the date Customer receives the Equipment. The subscription will automatically renew for additional 12-month terms unless either party provides the other with at least sixty (60) days' written notice of termination prior to the end of the initial term or any renewal term.
- Absent Customer's misuse of the Equipment, ISC will promptly repair or replace Equipment that malfunctions or fails. The Total Monthly Fee covers these exchanges, including all shipping and handling.
- Customer may increase Equipment at any time—monthly fees will be adjusted accordingly.
- ISC will send Equipment manuals (including operating instructions and warnings) following Customer's acceptance of this subscription offer.
- ISC will issue invoices on the last day of each month. Customer agrees to pay the Total Monthly Fee, as well as any applicable taxes and fees, within thirty (30) days of the invoice date. The Total Monthly Fee Price does not include taxes, GST, PST, customs, duties and all other related expenses; where applicable.

Pricing valid for 60 days from the quotation date stated above

OUR MISSION

Preserving human life on, above, and below the earth.
Delivering highest quality, best customer service—every transaction, every time.



Confidential and Proprietary.

- Net Customer Support is available at 1-877-FOR INET Monday thru Thursday 7AM to 8 PM (EST) and Friday 7AM to 6PM (EST) or inetadmin@indsci.com.
- ISC owns all Equipment and will lease it to Customer under the terms of this subscription offer. At the end of the subscription term, Customer will (i) return all Equipment to ISC; and (ii) pay ISC 50% of the then-current list price for any Equipment that was lost or damaged by misuse.
- Neither party shall be liable to the other party for any special, indirect, punitive, or consequential damages. Liability for all losses arising in connection with the subscription will be determined in accordance with applicable law.
- Customer may accept this offer by issuing a purchase order ("P.O.") to ISC referencing the Case # highlighted above and completing the Installation Site Information and Pre-Installation Acceptance Forms below. The offer in this Quote is valid for sixty (60) days from the date listed above.

ISC Contact (s)

Name: Cheryl McCalmon
Title: Business Development - Northeast & Appalachia
Phone: (412) 779-7220
Email: cmccalmon@indsci.com

Pricing valid for 60 days from the quotation date stated above

OUR MISSION

Preserving human life on, above, and below the earth.
Delivering highest quality, best customer service—every transaction, every time.



Confidential and Proprietary.

INDUSTRIAL SCIENTIFIC

Industrial Scientific Corporation
1 Life Way
Pittsburgh, PA 15205-7500, USA
Phone: 412-788-4353
1-800-DETECTS (338-3287)
Fax: 412-788-8353
www.indsci.com

2/24/2023

Warwick Fire Department - Warwick, RI
Justin Vail
111 Veterans Memorial Drive
Warwick, RI 02886
US

Dear Justin Vail

RE: iNet Instrument Network™

This letter serves to confirm that Industrial Scientific Corporation is the sole source provider of the proprietary iNet® Instrument Network.

Industrial Scientific remotely monitors the condition of your Industrial Scientific instrument fleet and automatically handles any necessary service requirements based on the Exchange plan that you have selected. In addition, the program also includes iNet® Control which provides visibility into your gas detection program via the web. By logging onto a secure website, you can review equipment usage, maintenance, and alarm events. iNet Control tells you when your gas detectors were last calibrated, whether a sensor is about to fail, and which gas detectors went into alarm that day. You can use detailed views to identify the source of potential problems, take action, and save lives.

Additional features if iNet include:

- **LENS™ Wireless:** LENS peer-to-peer monitoring allows personal monitors and area monitors to share gas readings and alarms with one another. When a gas hazard, man-down, or panic situation causes an instrument to alarm, all peers in the connected group will instantly be notified of the hazard and the person in danger.
- **iNet® Now:** iNet Now is live monitoring software that provides real-time text and email alerts for gas hazards, panic, and man-down situations allowing you to see and respond to incidents as they happen. A map helps you to identify the location of workers and instruments. With iNet Now, you can have confidence that workers are visible even when you're miles away.
- **Auto Replenishment Plus:** Our Auto Replenishment Plus program provides iNet® Exchange customers with the ~~option to have~~ the cost of calibration gas included in the monthly price of their iNet contract. Having ~~calibration gas included~~ in your iNet contract allows the monthly price to reflect the true total cost of ~~ownership of the equipment~~, making iNet a complete one-stop shop for gas detection.

There is no other comparable all-inclusive gas detection program like iNet in existence today.

Please contact us if we can be of further assistance.

Sincerely yours,

Corinne Doehre

Corinne Doehre
Sales Support Specialist

Case: 20230225-3809080

Request for Taxpayer Identification Number and Certification

**Give Form to the
 requester. Do not
 send to the IRS.**

▶ Go to www.irs.gov/FormW9 for instructions and the latest information.

Print or type.
See Specific Instructions on page 3.

1 Name (as shown on your income tax return). Name is required on this line; do not leave this line blank.
Industrial Scientific Corporation

2 Business name/disregarded entity name, if different from above

3 Check appropriate box for federal tax classification of the person whose name is entered on line 1. Check only one of the following seven boxes.

Individual/sole proprietor or single-member LLC

C Corporation

S Corporation

Partnership

Trust/estate

Limited liability company. Enter the tax classification (C=C corporation, S=S corporation, P=Partnership) ▶ _____

Note: Check the appropriate box in the line above for the tax classification of the single-member owner. Do not check LLC if the LLC is classified as a single-member LLC that is disregarded from the owner unless the owner of the LLC is another LLC that is not disregarded from the owner for U.S. federal tax purposes. Otherwise, a single-member LLC that is disregarded from the owner should check the appropriate box for the tax classification of its owner.

Other (see instructions) ▶ _____

4 Exemptions (codes apply only to certain entities, not individuals; see instructions on page 3):

Exempt payee code (if any) 5

Exemption from FATCA reporting code (if any) _____

(Applies to accounts maintained outside the U.S.)

5 Address (number, street, and apt. or suite no.) See instructions.
1 Life Way

6 City, state, and ZIP code
Pittsburgh, PA 15205

7 List account number(s) here (optional)

Requester's name and address (optional)

Part I Taxpayer Identification Number (TIN)

Enter your TIN in the appropriate box. The TIN provided must match the name given on line 1 to avoid backup withholding. For individuals, this is generally your social security number (SSN). However, for a resident alien, sole proprietor, or disregarded entity, see the instructions for Part I, later. For other entities, it is your employer identification number (EIN). If you do not have a number, see *How to get a TIN*, later.

Note: If the account is in more than one name, see the instructions for line 1. Also see *What Name and Number To Give the Requester* for guidelines on whose number to enter.

Social security number									
or									
Employer identification number									
2	5	-	1	4	8	1	2	8	1

Part II Certification

Under penalties of perjury, I certify that:

- The number shown on this form is my correct taxpayer identification number (or I am waiting for a number to be issued to me); and
- I am not subject to backup withholding because: (a) I am exempt from backup withholding, or (b) I have not been notified by the Internal Revenue Service (IRS) that I am subject to backup withholding as a result of a failure to report all interest or dividends, or (c) the IRS has notified me that I am no longer subject to backup withholding; and
- I am a U.S. citizen or other U.S. person (defined below); and
- The FATCA code(s) entered on this form (if any) indicating that I am exempt from FATCA reporting is correct.

Certification instructions. You must cross out item 2 above if you have been notified by the IRS that you are currently subject to backup withholding because you have failed to report all interest and dividends on your tax return. For real estate transactions, item 2 does not apply. For mortgage interest paid, acquisition or abandonment of secured property, cancellation of debt, contributions to an individual retirement arrangement (IRA), and generally, payments other than interest and dividends, you are not required to sign the certification, but you must provide your correct TIN. See the instructions for Part II, later.

Sign Here	Signature of U.S. person ▶	Betsy Chestnut	Digitally signed by Betsy Chestnut Date: 2021.10.06 15:32:24 UTC
------------------	----------------------------	-----------------------	--

General Instructions

Section references are to the Internal Revenue Code unless otherwise noted.

Future developments. For the latest information about developments related to Form W-9 and its instructions, such as legislation enacted after they were published, go to www.irs.gov/FormW9.

Purpose of Form

An individual or entity (Form W-9 requester) who is required to file an information return with the IRS must obtain your correct taxpayer identification number (TIN) which may be your social security number (SSN), individual taxpayer identification number (ITIN), adoption taxpayer identification number (ATIN), or employer identification number (EIN), to report on an information return the amount paid to you, or other amount reportable on an information return. Examples of information returns include, but are not limited to, the following.

- Form 1099-INT (interest earned or paid)

- Form 1099-DIV (dividends, including those from stocks or mutual funds)
- Form 1099-MISC (various types of income, prizes, awards, or gross proceeds)
- Form 1099-B (stock or mutual fund sales and certain other transactions by brokers)
- Form 1099-S (proceeds from real estate transactions)
- Form 1099-K (merchant card and third party network transactions)
- Form 1098 (home mortgage interest), 1098-E (student loan interest), 1098-T (tuition)
- Form 1099-C (canceled debt)
- Form 1099-A (acquisition or abandonment of secured property)

Use Form W-9 only if you are a U.S. person (including a resident alien), to provide your correct TIN.

If you do not return Form W-9 to the requester with a TIN, you might be subject to backup withholding. See What is backup withholding, later.

CODE: 35-301 Fire Department – Training & Education

SECTION 56-6

Bid2024-109 Operations & Asset Management Software

Vector Solutions
4890 West Kennedy Blvd. Suite 300
Tampa, FL 33609

Contract Award: \$16,000.00

Contract Period: 20 Months from Date of Award



Jason Umbenhauer
Assistant Chief

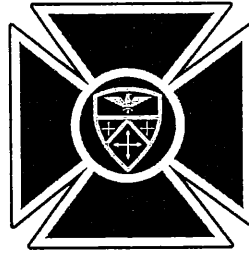

Office: (401) 468-4044
Fax: (401) 468-4043

Warwick Fire Department
111 Veterans Memorial Drive
Warwick, Rhode Island 02886

June 29, 2023

Francis Gomez
Purchasing Agent

The Fire Department is requesting a 56-6 exception to bid for Operations and Asset Management Software, to Vector Solutions of Tampa, FL , in the amount of \$16,000 for a 20-month contract term.

The Fire Department is requesting the addition of Vector Solution's Operations and Asset Management System (Check-It) which will supplement the already existing Scheduling and Learning Management System. Vector Solutions Check It is a comprehensive solution for streamlining routine inspections and maintenance for vehicles, equipment, controlled substances, medical supplies, and other logged inventory.

After a thorough evaluation of Vector Solutions Check It Software, the Fire Department strongly recommends the purchase of this software package. This software is accessible via the mobile application or any web-enabled device and makes it simple to perform and track inspections, ensure assets are functioning correctly, and identify needs for repair or maintenance. Vector Solutions Check It is the only operations and asset management system fully integrated with the Vector Solutions online training management system.

In addition, the Check-It software will provide the department with the following benefits:

- Integrated mobile application and web-based platform accessible 24/7 to complete inspections anytime, anywhere.
- Exclusive module for cradle-to-grave tracking of controlled substances
- Ability to securely track expiration dates of all types of controlled substances and other resources assigned to a specific vehicle, person, or storage facility.
- Built-in verification features, such as eSignatures, employee pin numbers, and facial recognition technology, to ensure accountability.
- Push notifications, email alerts, and custom check-step comments to communicate the completion of an inspection, create check-step comments, or notify supervisors of issues.
- Ability to open service tickets for an apparatus or piece of equipment in need of repair and track its status, costs, and other information with intuitive workflows.
- Produce comprehensive reports with visually driven data to view check history, performance, and other measurable steps.

Email: Jason.Umbenhauer@warwickri.gov

In addition, Vector Solutions is currently being utilized by 21 Fire Departments across the State of Rhode Island and provides services to numerous major municipalities nationally.

Vector Solutions is the sole source provider for its online operations and asset management system (Vector Solutions Check It), which was developed and provided solely by Vector Solutions.

The costs of this software will be funded through account 35-301 Training & Education.

Respectfully Submitted,

A handwritten signature in black ink, appearing to read "A/C" followed by a stylized name, likely "Jason Umbenhauer". The signature is written in a cursive, flowing style.

Jason Umbenhauer
Assistant Chief

Sole Source Justification

Training Management | Operations and Asset Management | Workforce Management

This document serves as a sole source justification for TargetSolutions' online training management system, operations and asset management system (TargetSolutions Check It™), and workforce management system (TargetSolutions Scheduling™), which are all developed and provided solely by TargetSolutions.

Service Description

TargetSolutions' industry-leading online training, operations and workforce management system is a comprehensive suite of proprietary web-based solutions for Fire and EMS departments and is the industry's only all-in-one operational hub for the management of training, assets and employee scheduling. The unique, one-of-a-kind software features exclusive fire department software tools, including best-in-class training courses and recordkeeping applications.

Here are TargetSolutions' online training management system's key differentiators that make it stand apart in the industry:

- TargetSolutions features the industry's leading learning management system for scheduling, delivering and tracking online training courses
- TargetSolutions offers more than 500 hours of training for fire departments, including more than 250 hours of accredited EMS continuing education courses
- TargetSolutions is organizationally accredited through CAPCE, the Commission on Accreditation for Pre-Hospital Continuing Education
- In addition to EMS continuing education, TargetSolutions features NFPA 1001, NFPA 1021, NFPA 1410, NFPA 1500, as well as Occupational Safety and Health Administration (OSHA), and much more in its training catalog
- The TargetSolutions platform features unique applications for managing fire department training, recordkeeping, and compliance tasks, including:
 - Activities Builder
 - Credentials Manager
 - ISO Training Tracker
 - Community Resources
 - File Center
 - Test Builder
 - Generate Reports
 - Events Manager
- The TargetSolutions platform can be extended to *TargetSolutions Check It™* operations and asset management system for conducting inspections of equipment, apparatus and inventory

TargetSolutions Check It™ is a comprehensive solution for streamlining routine inspections and maintenance for vehicles, equipment, controlled substances, medical supplies, and other logged inventory.



Accessible via the mobile application or any web-enabled device, TargetSolutions Check It™ makes it simple to perform and track inspections, ensure assets are functioning correctly, and identify needs for repair or maintenance. TargetSolutions Check It™ is the only operations and asset management system fully integrated with the TargetSolutions online training management system.

Whether conducting an apparatus check, counting inventory of controlled substances, or inspecting equipment, TargetSolutions Check It™ enables agencies to track and report it all.

Here are the key differentiators of TargetSolutions Check It™ that make it stand apart in the industry:

- Integrated mobile application and web-based platform accessible 24/7 to complete inspections anytime, anywhere.
 - Exclusive module for cradle-to-grave tracking of controlled substances
 - Ability to securely track expiration dates of all types of controlled substances and other resources assigned to a specific vehicle, person, or storage facility.
 - Built-in verification features, such as eSignatures, employee pin numbers, and facial recognition technology, to ensure accountability.
 - Push notifications, email alerts, and custom check-step comments to communicate the completion of an inspection, create check-step comments, or notify supervisors of issues.
 - Ability to open service tickets for an apparatus or piece of equipment in need of repair and track its status, costs, and other information with intuitive workflows.
 - Produce comprehensive reports with visually-driven data to view check history, performance, and other measurable steps.
-
- TargetSolutions Check It™ features the exclusive Controlled Substances™ module for cradle-to-grave tracking of narcotics
 - TargetSolutions' CrewSense workforce management system provides employee resourcing and human capital management software
 - TargetSolutions' enterprise solution enables agencies to collaborate in a shared location while still managing their own TargetSolutions platform sites

TargetSolutions Scheduling™ powered by CrewSense is a total workforce management solution built for the complex organizational tasks of mission-critical industries.

With TargetSolutions, you can simplify employee scheduling, callbacks, and overtime hiring with intelligent rules to ensure each shift is adequately staffed with qualified personnel.

Automation tools streamline time-off requests and shift swapping to eliminate conflicts and grievances, determine tiebreakers, place employees in multiple rotating lists, and more.



Here are the key differentiators of TargetSolutions Scheduling™ that make it stand apart in the industry:

- A snapshot overview of shift schedules, minimum staffing levels, and employees' qualification in a dynamic workforce management dashboard.
- Cloud-hosted, reliable data that is available 24/7 and accessible via the mobile application or any web-based device.
- Interactive roster map with a live view of employee locations, traffic patterns, and 'hot spot' areas.
- Automatization tools to streamline overtime hiring, callbacks, and vacation requests with custom qualifiers to reduce human error or bias.
- Shift trade dashboard for employees to self-manage shifts trades (based on qualifications) and hours owed/credited to coworkers.
- Customizable and exportable reports with in-depth filters to analyze employee hours, payroll, overtime, and more.

CODE: 67-406 Engineering – Greenwich Bay Project

SECTION 56-6

Bid2024-103 Buy Out for Big Belly Solar Trash Units

Big Belly LLC
150 A Street Suite 103
Needham, MA 02494

Contract Award: \$12,500.00

Contract Period: One Time Purchase



CITY OF WARWICK
DEPARTMENT OF PUBLIC WORKS
925 SANDY LANE • WARWICK, RHODE ISLAND 02889
TEL (401) 738-2003 • FAX (401) 732-5208

FRANK J. PICOZZI
MAYOR

ERIC J. EARLS, PE
DIRECTOR OF PUBLIC WORKS

JUN 28 2023

To: Francis Gomez, Purchasing Agent

From: Eric J. Earls, Director of Public Works *EJE*

Date: June 26, 2023

Subj: Big Belly LLC

This department is requesting an Exception to Notice for Big Belly LLC to purchase the (10) ten trash units located in Oakland Beach. It was previously requested to have the units removed at a cost of \$6,250 and would have left this area with no trash receptacles. This department finds it in the best interest of the City to purchase these units outright and retain ownership. These units were leased for five years under a previous contract.

Please consider this memo a request for an exception to notice under Sec. 56-6 of the Warwick Code for Big Belly LLC for a lump sum of \$12,500 to purchase the 10 trash units at Oakland Beach. This is a one-time fee and therefore no contract period is necessary.

(67-406 - \$12,500)

Moretti Christy L

To: Moretti Christy L
Subject: FW: [EXT] - Bigbelly Options: Renewal, Refresh, Buyout

From: Josh Erhard [mailto:jerhard@bigbelly.com]
Sent: Thursday, June 22, 2023 5:03 PM
To: Earls Eric J <eric.j.earls@warwickri.gov>
Subject: [EXT] - Bigbelly Options: Renewal, Refresh, Buyout

Caution! This message was sent from outside your organization.

Hi Eric,

I hope all is well with you.

After some discussion and planning on our side, I have come up with a couple of options for your bins--avoiding removing them entirely.

Option 1: Connect Renewal

This option would continue your renewal contract as it was for the last 5 years and would include the full term parts warranty, factory warranty, monitoring software access, yearly cleanings & inspections, and a *full station refresh*. Making your existing bins as close to 'new' as possible. Based on your photos and assessment of the bins, the full station refresh would include all new batteries, front doors, foot pedals, solar bubbles, locks, and keys on all of your bins--a value with a high price tag when not bundled in with the renewal cost.

Price: \$52,000 paid over 36 months. Just shy of \$1,450 per month for all 10 stations.

Option 2: Station Buyout with Refresh Add on

This option involves the buyout of your bins from Bigbelly. Because you originally acquired the bins under our Connect Rental Program, we still maintain ownership of the bins. Buying out the bins would render them your property, and allow you to take ownership and responsibility of them for the indefinite future. This option also includes the cost of the station refresh but *does not include costs related to warranties, monitoring software access, or yearly cleanings & inspections*.

Price: One-time fee of \$25,000 paid upon contract agreement, no recurring fees.

Option 3: Station Buyout, Stations as is *

This option is the same as option 2, but does not include the full station refresh. As the most modest option here, it would allow you to establish ownership of the bins and have them repaired on a case-by-case basis to get them all back to working order.

Price: One-time fee of \$12,500 paid upon contract agreement, no recurring fees.

Let me know if you would like to discuss these options on a call! There are a lot of details to elaborate on and adjustments we can make at your request as well.

I look forward to hearing from you.

Best,

Josh

--

Josh Erhard

Senior Sales Development Associate - East Coast

150 A Street, Suite 103 | Needham, MA 02494 USA

+1 888.820.0300 main

+1 888.820.0300 Ext. 342 | +1 617.691.5111 direct

Need Help? support@bigbelly.com | +1 888-820-0300 Ext. 3

www.bigbelly.com

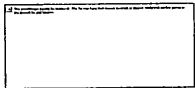

CODE: 510-0400 ARPA Expenditures

SECTION 56-10

Request permission to piggyback MPA #584

Bid2024-086 Pilgrim Senior Center Building Assessment

Building Enclosure Science LLC
Dba Building Enclosure Science
859 N Main St.
Providence, RI 02904

Contract Award: \$10,800.00

Contract Period: Date of Award – 6/30/2024

JUN 15 2023



CITY OF WARWICK
DEPARTMENT OF PUBLIC WORKS
925 SANDY LANE • WARWICK, RHODE ISLAND 02889
TEL (401) 738-2003 • FAX (401) 732-5208

FRANK J. PICOZZI
MAYOR

ERIC J. EARLS, PE
DIRECTOR OF PUBLIC WORKS

To: Francis Gomez, Purchasing Agent

From: Eric J. Earls, Director of Public Works *EJE*

Date: June 15, 2023

Subj: MPA #584 – State bid – Building Enclosure Science LLC

The State of Rhode Island has awarded MPA #584 to Building Enclosure Science LLC for building assessments. The Department of Public Works would like to do the same. This request is specifically for a building assessment of Pilgrim Senior Center. This facility was constructed in 1990 and primarily serves the senior citizen population in the City of Warwick. Due to the age of this building, this request is made to have the building evaluated with a concentration on particular areas as noted in the quote. This vendor will be able to provide the City with a comprehensive overview of the needs and improvements for this building to serve the City of Warwick seniors for years to come. As well, it will allow the City to prioritize upgrades and repairs that are recommended.

Furthermore, it should be noted that this facility serves as a heating and cooling center when necessary, as well as a shelter during emergencies.

Please accept this memo as a request for Sec. 56-10 of the City Charter to piggyback State bid MPA #584 for Building Enclosure Science LLC for a full building assessment of the Pilgrim Senior Center. The requested amount is \$10,800 and funds are designated in the Senior Services ARPA FY24 request.

(510-0400 - \$10,800)

JUN 15 2023

Notice of Contract Purchase Agreement



**State Of Rhode Island
Department of Administration
Division of Purchases
One Capitol Hill
Providence, RI 02908-5860**

V E N D O R	BUILDING ENCLOSURE SCIENCE LLC DBA BUILDING ENCLOSURE SCIENCE 859 N MAIN ST PROVIDENCE, RI 02904-5761 United States
----------------------------	--

MPA 584 ENGINEERING SERVICES	
Award Number	3722015
Revision Number	0
Effective Period	01-JUL-2021 - 30-JUN-2024
Approved PO Date	14-JUN-2021
Vendor Number	50100

S H I P T O	MASTER PRICE AGREEMENT SEE BELOW RELEASE AGAINST, RI MPA United States
--------------------------------	---

Type of Requisition	ARCH, ENG & CONSULT
Requisition Number	
Change Order Requisition Number	
Solicitation Number	
Freight	Paid
Payment Terms	NET 30
Buyer	Bovis, Thomas
Requester Name	
Work Telephone	

This Purchase Order is issued pursuant to and in accordance with the terms and conditions of the solicitation and applicable federal, state, and local law, including the State of Rhode Island's General Conditions of Purchase which are incorporated herein by reference contain specific contract terms applicable to this Purchase Order. See: <https://rules.sos.ri.gov/regulations/part/220-30-00-13>

CONTRACT TERM: 07/01/2021 – 06/30/2024

CONTRACT MAY BE RENEWED FOR UP TO ONE (1) ADDITIONAL 12-MONTH PERIOD BASED ON VENDOR PERFORMANCE AND THE AVAILABILITY OF FUNDS.

MASTER PRICE AGREEMENT #584

PROVIDE ENGINEERING SERVICES IN ACCORDANCE WITH THE PROVISIONS OF OSP SOLICITATION

INVOICE TO
IMMEDIATE VENDOR ACTION REQUIRED: Paperless Invoicing is now required. Vendors who do not currently invoice electronically must comply. Get Instructions at : http://controller.admin.ri.gov/documents/Communications/Vendor%20Information/Paperless%20Invoicing%20Initiative_09-01-2020.pdf
REGISTRATION REQUIREMENTS
IMMEDIATE VENDOR ACTION REQUIRED: ALL vendors with an existing Purchase Order must be registered in OCEAN STATE PROCURES(OSP). Get Instructions at : https://www.ridop.ri.gov/osp/osp-vendor-registration.php

STATE PURCHASING AGENT
 Nancy R. McIntyre

JUN 15 2023

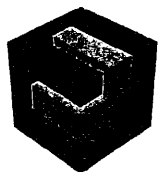

Building Enclosure Science

June 15, 2023

Client: Mr. Eric Earls
Public Works Director
City of Warwick
925 Sandy Lane
Warwick, RI 02886

Project: Pilgrim Senior Center
27 Pilgrim Parkway
Warwick, RI

Re: Condition Assessment (Building Envelope)

Dear Mr. Earls:

Building Enclosure Science (BES) is a full-service construction consulting firm specializing in the investigation, testing, design, commissioning, and quality assurance of claddings, fenestrations, foundations, and roofing, collectively referred to as "Building Enclosure" systems.

Enclosed is our proposal for services for the Pilgrim Senior Center located at 27 Pilgrim Parkway, Warwick RI, and specifically services related to the building envelope.

Services:

Condition Assessment: Provide a condition assessment with focus on the building envelope.

- ❖ Interview present knowledgeable parties to review reported deficiencies, document findings, and building work chronology.
- ❖ Review available, owner-provided design documents, previously completed reports, and as-built documentation.
- ❖ Provide an on-site visual condition assessment of the building envelope, with focus on the roof, masonry, glazing, exterior patios, and reported areas of water intrusion.
- ❖ Provide a written summary report that includes assessment findings, order of magnitude budget for deficiency repairs, scope prioritization chart for annual asset management, and recommended next steps.
- ❖ Attend up to one (1) meeting with the client to review findings.

Cost:

The enclosed services will be billed on a percent complete basis, with invoices submitted monthly.

Condition Assessment:

\$10,800.00

BuildingES.com

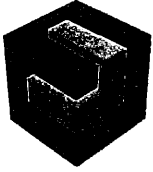

Building Enclosure Science LLC

Notes:

1. Aerial lift equipment is not included in this proposal.
2. Mechanical assessment is not included in this proposal.
3. Repair design and construction phase services are available via follow-up proposals, though are not currently included in this proposal.
4. The proposal does not include hazardous material testing.

Acceptance:

By signing below, the listed are attesting to being agents of each Party listed herein and by their signature agree to this Proposal in its entirety, without alterations or revisions, making this an Agreement.

City of Warwick (Client)

Signature: _____ Date: _____

Printed Name: _____ Title: _____

Building Enclosure Science, LLC

Signature: _____ Date: _____

Printed Name: _____ Title: _____

Attachment:

Contract Provisions

CODE: 30-330 Police Department – Auto & Vehicle Maintenance

SECTION 6-12

Request permission to increase PCR-145-22 (Sub A) from \$10,000.00 to \$20,000.00.

Bid2023-239 Emergency Equipment Repair for Police Vehicles

Global Public Safety
60 Alhambra Rd.
Suite #6
Warwick, RI 02886

All Mobile Towing & Recovery LLC
PO Box 14544
East Providence, RI 02914

LAST ACTION TAKEN

Award (Sec. 6-12): PCR-45-22 (Sub A) approved on December 22, 2022 in the amount of \$10,000.00.
Contract period February 10, 2023 through February 9, 2024.

Contract Increase Requested:	\$10,000.00
Current Contract Award:	\$10,000.00
Contract Period Requested	No Change in Contract Period
Current Contract Period	2/10/2023 – 2/9/2024

CITY OF WARWICK

Colonel Bradford Connor
Chief of Police

Frank J. Picozzi
Mayor



JUN 29 2023

Police Department
99 Veterans Memorial Drive
Warwick, Rhode Island 02886-4617
Telephone: (401) 468-4200

June 28, 2023

Ms. Francis M. Gomez, Purchasing Agent
Warwick City Hall
3275 Post Road
Warwick, RI 02886

RE: 6-12 Alteration to bid
Emergency Equipment Repairs for Police Vehicles
Bid #2023-239
Funding Source: Auto and Vehicle Maintenance - 30-330

Dear Ms. Gomez:

The Police Department previously went out to bid for emergency equipment repairs for police vehicles. These repairs include items such as the repair & installation of light bars, siren/light control boxes, siren speakers, the two-way radio system, portable radio chargers, all aspects of the MDT to include the MDT stand, docking station, keyboard and printer system, prisoner containment system, and the shotgun/rifle rack system.

The bid was awarded to both bid-submitting vendors:

1. All Mobile Towing, LLC, 102B Pond St., Seekonk MA 02771
2. Global Public Safety, 60 Alhambra Rd., Suite 6, Warwick RI 02886

The police department is seeking a \$10,000 increase in spending authority due to unforeseen expenses which leaves this bid with insufficient funds to last until the bid expiration date of 2/9/24. The shortfall is due in large part to vehicles we purchased that did not include all necessary emergency equipment and/or it was cheaper to use this bid to upfit these vehicles as opposed to having it included with the original vehicle purchase.

The \$10,000.00 increase in spending authority will increase the total bid to \$20,000 for the one-year contract which began on 2/10/23 and ends 2/9/24.

If approved, it will be funded by Police Operating budget code: 30-330. Repairs will continue to be made on an as-needed basis.

If you have any questions or concerns, please contact me at 468-4230.

Sincerely,

A handwritten signature in black ink, appearing to read 'Andrew P Sullivan'.

Major Andrew P Sullivan
Administrative Bureau Commander
Warwick Police Department

CITY OF WARWICK
 STATE OF RHODE ISLAND
 RESOLUTION OF THE CITY COUNCIL

MEETING DATE: 12/19/2022

NO: R-22-124

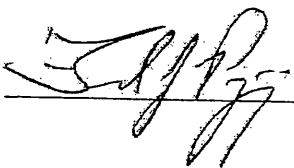
APPROVED:  MAYOR

DATE: 12-22-22

RESOLVED, That The City Council of the City of Warwick as required by the provisions of Sections 6-11 and 6-12 of the City Charter and the Ordinance relative to competitive bidding on purchase enacted there under hereby and herewith approves the acceptance of the following bid(s):

Bid #	Name	Vendor(s) Name/Address	Contract Award	Contract Period	Note	Code
2023 - 300	State of RI Vehicle Repairs	<i>Ballard Mack Sales & Serv of RI Inc. Diesel Maintenance Services LLC Fleet Master Inc. Paul Massé Chevrolet Inc. Rhode Island Diesel Equipment Service LLC Smithfield Diesel & Transmission Repair Inc. Strobes & More Tasca Automotive Group Inc.</i>	\$300,000.00 Inclusive of Bid 2023-300 & 2023-301	Date of award - 6/30/25	1	56 - 10

Continued next page

PCR-145-22 (Sub A)

Bid #	Name	Vendor(s) Name/Address	Contract Award	Contract Period	Note	Code
2023 - 301	State of RI Automotive and Truck Repairs Heavy Trucks	<i>Advantage Truck Raynam LLC</i> <i>AT Northen Warwick LLC d/b/a Coastal International</i> <i>Ballard Mack Sales & Serv of RI Inc.</i> <i>Diesel Maintenance Services LLC</i> <i>Fleet Master Inc.</i> <i>Rhode Island Diesel Equipment Service LLC</i> <i>Rhode Island Truck Center LLC</i> <i>Smithfield Diesel & Transmission Repair Inc.</i> <i>Strobes & More</i> <i>Tasca Automotive Group Inc.</i>	Inclusive of Bid 2023-300 & 2023-301	Date of award - 6/30/25	2	56 - 10
2023 - 251	Purchase 2023 or Newer Chevrolet 3500 HD	<i>Liberty Chevrolet, Inc.</i> 90 Bay State Road Wakefield, MA 01880	\$203,244.00			
2023 - 245	Copier Equipment, Service, & Maintenance	<i>Aztec Office</i> 984 Charles Street N. Providence, RI 02904 <i>Innovex</i> 11 Powder Hill Road Lincoln, RI 02865 <i>Axion/Visual Edge IT</i> 80 Cypress St. Warwick, RI 02888	\$125,000.00	1/1/23 - 12/31/25		

Continued next page

PCR-145-22 (Sub A)

Bid #	Name	Vendor(s) Name/Address	Contract Award	Contract Period	Note	Code
2023 - 304	Purchase Ford F-150 Responder Vehicles	<i>McGovern Municipal Headquarters</i> 1200 Worcester Road Framingham, MA 01702 <i>Colonial Municipal Group</i> 61 Camelot Dr. Plymouth, MA 02360	\$120,184.80			56 - 6
2023 - 162	Purchase 2023 Chevrolet 3500 HD w/ Plow Package & Dump Body or Equivalent	<i>Liberty Chevrolet, Inc.</i> 90 Bay State Road Wakefield, MA 01880	\$82,729.00		3	6 - 12
2023 - 289	IMC Software Support	<i>Tritech Software Systems, a Central Square Co</i> 1000 Business Center Drive Lake Mary, FL 32746	\$58,435.93	1/1/23 - 12/31/23		56 - 6
2023 - 302	Chevrolet Silverado 2500HD 4WD Double Cab	<i>Colonial Municipal Group CMG</i> 61 Camelot Drive Plymouth, MA 02360	\$51,773.63			56 - 6
2023 - 310	State of RI Software and Services for Database Programming	<i>Accelare</i> <i>CBTS LLC</i> <i>Dell Marketing LP</i> <i>Deloitte Consulting LLP</i> <i>Insight Public Sector, Inc.</i> <i>IntraSystems, Inc.</i> <i>Markley Boston LLC</i> <i>Stonewall Solutions Inc.</i> <i>Zones LLC</i>	\$30,000.00	1/1/23 - 12/31/23	4	56 - 10

Continued next page

PCR-145-22 (Sub A)



Bid #	Name	Vendor(s) Name/Address	Contract Award	Contract Period	Note	Code
2023 - 239	Emergency Equipment Repair for Police Vehicles	<i>Global Public Safety</i> 60 Alhambra Rd. Suite #6 Warwick, RI 02886 <i>All Mobile Towing & Recovery LLC</i> P.O Box 14544 East Providence, RI 02914	\$10,000.00	2/10/23 - 2/9/24		
2023 - 190	Automotive Graphics Replacement	<i>MHQ</i> 401 Elm St. Marlboro, MA 01752 <i>Global Public Safety</i> 60 Alhambra Road Suite 6 Warwick, RI 02886	Additional Vendor		5	6 - 12
2023 - 308	State of RI Automated External Defibrillators & AED Equipment	<i>Stryker Sales Corporation</i> 2825 Airview Blvd. Portage, MI 49002	\$28,908.75		6	56 - 10
2023 - 309	Entry-Level Firefighter Written Examination	<i>IPMA-HR</i> 1617 Duke St. Alexandria, VA 22314	\$4,620.00			56 - 6
2023 - 299	Remove & Replace Hanging Systems	<i>D. Larsen & Son</i> 2 Huckleberry Ct. Warwick, RI 02888	\$23,940.00			56 - 6
2023 - 298	Reinstall Unit at McDermott Pool	<i>D. Larsen & Son</i> 2 Huckleberry Ct. Warwick, RI 02888	\$17,415.00			56 - 6

Continued next page

Bid #	Name	Vendor(s) Name/Address	Contract Award	Contract Period	Note	Code
2023 - 297	Install Indoor & Outdoor Camera System	<i>Electronic Alarms</i> 10 Jefferson Blvd. Warwick, RI 02888	\$15,901.48			56 - 6
2023 - 311	Municipal Court Software & Support	<i>Curia Systems, Inc.</i> PO Box 2031 East Greenwich, RI 02818	\$10,000.00	9/1/22 - 8/31/23		56 - 6
2023 - 316	Repairs to W16	<i>Affordable Auto Body</i> 96 Evergreen Ave. Warwick, RI 02888	\$13,627.77			56 - 6

AND BE IT FURTHER RESOLVED, That such purchase or contract be awarded to the lowest responsible bidder.

1. Request permission to piggyback State MPA#203A
2. Request permission to piggyback State MPA#203B
3. Request permission to increase PCR-114-22 (Sub A) from \$248,187.00 to \$330,916.00.
4. Request permission to piggyback State MPA#227
5. Request permission to award PCR-118-22 (Sub A) to MHQ as an additional vendor.
6. Request permission to piggyback State MPA#370

Actions Taken:

2023-288 Food and Paper Products

PCR-147-22
Held 01/04/2023

THIS RESOLUTION SHALL TAKE EFFECT UPON ITS PASSAGE

Bid2023-239 Emergency Equipment Repair for Police Vehicles

COPY

- 2 bids received

CODE: 30-330 Police Dept./Auto & Vehicle Maintenance

MANNER OF AWARD: \$10,000.00
February 10, 2023 – February 9, 2024

RECOMMEND: Global Public Safety
All Mobile Towing & Recovery LLC

Global Public Safety
60 Alhambra Rd. Suite #6
Warwick, RI 02886

All Mobile Towing & Recovery LLC
P.O Box 14544
East Providence, RI 02914

Item #	Description - Repairs	Global Public Safety	All Mobile Towing
1	Onsite Emergency repairs at WPD Garage within 4 hours of notification	\$100.00	\$90.00
2	Onsite Non-Emergency repairs at WPD garage within 24 Hours of Notification	\$85.00	\$80.00
3	Provide Pickup and drop off of vehicle/product when said vehicle cannot be repaired at WPD Garage	\$25.00	\$25.00-75.00

COPY

Bid2022-279 Emergency Equipment Repairs for Police Vehicles						
The Following vendors received bid specifications						
VENDOR	ADDRESS	CITY	STATE	ZIP	EMAILS	
Adamson Industries	45 Research Dr.	Haverhill	MA	01832	sales@adamsonindustries.com	
All Mobile Towing and Repair	PO Box 14544	East Providence	RI	02914	jreis14@aol.com	
Global Public Safety LLC	2780 Commerce Dr. Suite 300	Middletown	PA	17057	Teresa.Allen@globalpublicsafety.us; Pleon@itsg.us.com;	
Island Tech Services	980 So. 2nd St.	Ronkonkoma	NY	11779	Rwarner@itsg.us.com kkoster@329marketinginc.com	
Kory Koster/329 Marketing Inc. MHQ	401 Elm St.	Marlboro	MA	01752	bharrington@MHQ.com	
Safety Lighting & Equipment	38 Winthrop St.	Rehoboth	MA		sales@publicsafetyarmory.net	

CITY OF WARWICK

COPY

Colonel Bradford Connor
Chief of Police

Frank J. Picozzi
Mayor



NOV 18 2022

Police Department
99 Veterans Memorial Drive
Warwick, Rhode Island 02886-4617
Telephone: (401) 468-4200

November 17, 2022

Ms. Francis M. Gomez, Purchasing Agent
Warwick City Hall
3275 Post Road
Warwick, RI 02886

RE: Emergency Equipment Repairs for Police Vehicles
Bid #2023-239
Funding Source: Auto and Vehicle Maintenance - 30-330

Dear Ms. Gomez:

The Police Department went out to bid for emergency equipment repairs for police vehicles. These repairs include items such as the repairs of light bars, siren/light control boxes, siren speakers, the two-way radio system, portable radio chargers, all aspects of the MDT to include the MDT stand, docking station, keyboard and printer system, prisoner containment system, and the shotgun/rifle rack system.

Bids were received from two vendors:

1. All Mobile Towing, LLC, 102B Pond St., Seekonk MA 02771
2. Global Public Safety, 60 Alhambra Rd., Suite 6, Warwick RI 02886

The police department recommends that both **All Mobile Towing, LLC** and **Global Public Safety** be awarded this contract. We are seeking both vendors due to the time delays currently being experienced because of ongoing supply & labor shortages. The option to have multiple vendors will hopefully allow the cruisers that are off line to be fixed quicker. The rest of the cruiser fleet is taxed even when just one or two cruisers are taken offline. It is imperative that the garage has the ability to get these repairs done in a timely manner, which is why the department is requesting both vendors.

The ~~current contract~~ expires on 2/9/23.

The department is requesting \$10,000.00 for a one-year contract commencing 2/10/23 and ending 2/9/24.

If approved, it will be funded by Police Operating budget code: 30-330. Repairs will be made on an as needed basis.

If you have any questions or concerns, please contact me at 468-4230.

Sincerely,

Major Andrew P Sullivan
Administrative Bureau Commander
Warwick Police Department

CODE: 34-354 Warwick Emergency – ~~Emergency~~ Operations

SECTION 56-6

Bid2024-098 Code Red Emergency Notification Systems

OnSolve
6240 Avalon Blvd.
Alpharetta, GA 30009

Contract Award: \$9,500.00

Contract Period: October 3, 2023 – October 2, 2024

JUN 27 2023



Jason Umbenhauer
Assistant Chief

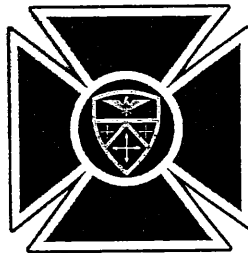

Office: (401) 468-4044
Fax: (401) 468-4043

Warwick Fire Department
111 Veterans Memorial Drive
Warwick, Rhode Island 02886

June 26, 2023

Francis Gomez
Purchasing Agent
City of Warwick

The Fire Department is requesting a 56-6, exception to bid, for OnSolve – 6240 Avalon Blvd, Alpharetta, GA to maintain the Code Red notification system.

The State of Rhode Island through the Rhode Island Emergency Management Agency entered into an agreement with this sole source provider to provide the Code Red Emergency Notification System statewide to cities and towns throughout the state for emergency notifications. The annual cost for the system is \$9,500.00. This allows the City of Warwick to conduct emergency notifications within our municipality.

This system has proven to be a benefit to our City in the past. We feel it is in the best interest of the City to maintain this notification option for future events that will affect our local jurisdiction. This system keeps citizens informed, is easily accessed via the City and State websites, and is free for citizens to subscribe.

The total amount requested is \$9,500.00 for the period of 10/03/2023 to 10/02/2024. The funds will come from budget code 34-354.

Please contact me should you have any questions.

Jason Umbenhauer
Assistant Chief

Email: Jason.Umbenhauer@warwickri.gov



Sales Quote: Q-563252

Offer Expires: July 26, 2023

Prepared for:
 Peter McMichael
 Fire Chief
 City of Warwick, RI
 111 Veterans Memorial Drive
 Warwick, RI 02886
 (401) 468-4049
 peter.k.mcmichael@warwickri.com

Prepared by:
 Michelle Gogarty
 Account Manager
 OnSolve
 6240 Avalon Blvd
 Alpharetta, GA 30009

 (866) 939-0911 x1340
 michelle.gogarty@onsolve.com

Payment Terms: Net 30
Billing Frequency: Annually
Currency: USD

Subscription Service Fees

Critical Communications

Item/Description	Order Term	Qty	Annual Price*	Term Total
CodeRED Standard Renewal	10/03/2023 - 10/02/2024	1	\$9,500.00	\$9,500.00
Critical Communications Subscription Fees				\$9,500.00

ORDER TOTAL **\$9,500.00**

Annual Fees

Year 1 Subscription Fees + Non-Recurring Service Fees	\$9,500.00
--	-------------------

*The Fees shown above may have been rounded to two decimal places for display purposes. As many as ten decimal places may be present in the actual price. The totals for this order were calculated using the actual price, rather than the Fees displayed above, and are the **true and binding** totals for this order.

CODE: 84-363 Water Department – Water Main Maintenance

SECTION 56-6

Bid2024-104 Purchase New Kamstrup Water Meter

F.W. Webb Company
150 Locust Street
Hartford, CT 06114

Contract Award: \$9,020.00

Contract Period: One Time Purchase

JUN 28 2023

Terry DiPetrillo
Division Chief



Frank J. Picozzi
Mayor

Michael St.Pierre
Business Manager

CITY OF WARWICK

DEPARTMENT OF PUBLIC WORKS

DIVISION OF WATER

935 SANDY LANE • WARWICK, RHODE ISLAND 02889

Tel (401) 738-2008

To: Francis Gomez, Purchasing Agent

From: Terry DiPetrillo, Chief of Water Division 

Date: June 28, 2023

Subj: Kamstrup flowIQ 4200 Water Meter

The Warwick Water Division is requesting an exception to notice to Purchase one (1) Kamstrup flow IQ 4200 Water Meter from FW Webb.

While the two 30 inch water main lines located on Pettaconsett Avenue and Post Road are shut down for rehabilitation. We will need to activate the emergency interconnection located on Wheatland Avenue to assure residents do not have interruption of service. Before doing so, Providence Water Supply Board is requiring that we install a new meter along with meter set up located on Wheatland Avenue.

Please consider this memo a request for an exception to notice under Sec. 56-6 of the code for FW Webb in the amount of \$9,020.00 for the purchase of one (1) Kamstrup flow IQ 4200 Water Meter. Funding will be derived from budget code 84-363. This is a one-time expense therefore no contract period is necessary.

(84-363 \$9,020.00)



F.W. WEBB COMPANY

150 LOCUST STREET
HARTFORD, CT 06114
Phone: 860-522-9322 Fax: 860-246-3718

This is your Quotation from F.W. Webb Company.
Please review the products listed on this quotation for accuracy and completeness.

Quotation number: 79850299	Ship to: Providence Water Supply Board 125 Dupont Drive Providence, RI 02907-3105 401-521-6300	Bill to: Providence Water Supply Board 125 Dupont Drive Providence, RI 02907-3105 401-521-6300
Quote Date : 02/28/2023		

Cust.Nbr: 79467	Customer PO: LEO FONTAINE	Rel:	Job:	Quoted By: ROBC	Requested: 02/28/2023
--------------------	------------------------------	------	------	--------------------	--------------------------

Quantity	Description	Net Price	Total
1	Kamstrup KAM5706567016236 Wtr Mtr lq4200 8" Amr Fig Ss 20" Cuff	\$6,002.000	\$6,002.00
1	Kamstrup KAM6696051 Sftrwr Ready 1-100 Amr F/wtr Mtr	\$1,001.000	\$1,001.00
1	Kamstrup KAMUS6696051FH Hosting Subscription Yrly 1-100 Amr	\$992.000	\$992.00
1	Kamstrup KAM669640000 Ready Converter Kit F/amr Wtr Mtr Bsc	\$1,025.000	\$1,025.00

Subtotal	\$9,020.00
Shipping	\$0.00
Handling	\$0.00
Tax	\$0.00
Total	\$9,020.00

Thank you for the opportunity to provide product pricing to meet your business needs.
Please visit our website for additional products or information <http://www.fwebb.com>
This Quotation is valid for 15 days after the above Quote Date.
* Restocking fees may apply on any Special Order Items.

Please Note: This email was sent from a notification-only address that cannot accept incoming email. Please do not reply to this message.

Data sheet

flowIQ® 4200

- Ultrasonic measurement
- Sustainable measurement accuracy
- Flow measurement in display
- Dual band radio
 - AMR (Walk-by/drive-by)
 - AMI (Fixed network)
- IP68 Vacuum sealed construction
- Load free and certified to NSF/ANSI 61
- Replaceable battery
- Coated split flanges in cast iron

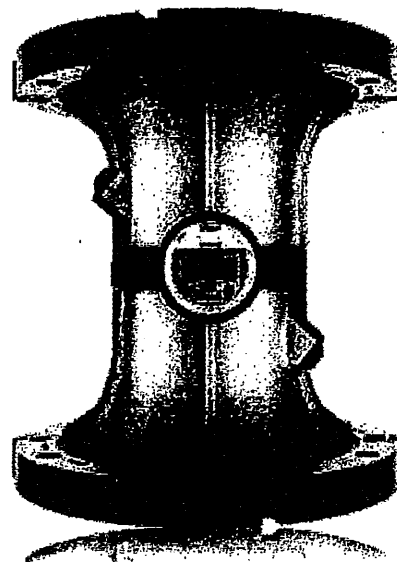

Contents

Technical data	4
Material	5
Meter sizes	5
Meter face details	6
Sensor Information	6
Replaceable battery	7
Display and info codes	7
Data registers	8
Radio package options	9
State of the art meter reading system (READY)	10
Pressure loss	10
Ordering details	11
Configuration - flowIQ® 4200	12
Dimensional sketches	14
Accessories	16

Electronic ultrasonic cold water meter for measurement of cold water consumption in households, multi-unit buildings and industry.

Sustainable accuracy

Ultrasonic flow measurement guarantees sustainable accuracy and longevity. Ultrasonic flow measurement is based on the transit time method, and all measurements, references, readings, calculations and data communication are controlled by an advanced, specially designed electronic circuit. Thus, the meter includes no moving parts, which makes flowIQ® 4200 less sensitive to wear and tear and impurities in the water.

Construction

The meter is hermetically closed and vacuum-sealed to prevent humidity from reaching the electronics and avoid condensation between the glass and display. The meter is IP68 (submersible) and is suitable for installation in meter pits.

Installation

flowIQ® 4200 is easy to install horizontally as well as vertically, independent of piping and installation conditions. Consumption data can be read visually from the display, using an optical IR interface head, or remotely read, either by 912.5, 915 or 918.5 MHz (AMR) and 450-470 MHz (AMI) band RF signal, built into the meter.

Specific features

flowIQ® 4200 measures the environment temperatures. The battery package is replaceable. flowIQ® 4200 is utilizing split flanges allowing for flexible installation options.

Environmentally friendly

The meter has been approved according to Drinking Water Standards in multiple countries, and it is certified to NSF/ANSI 61. The meter housing is made of stainless steel which is free from lead and other heavy metals. The environmental report, Carbon Footprint, documents the meter's high reusability and low environmental impact, including recycling of materials.

Hygiene

To protect the health of the consumers Kamstrup has a hygienic manufacturing process of the water meters. Kamstrup has a highly automated manufacturing process, and only uses materials which are approved for drinking water. The hygiene is being controlled by external accredited laboratories and by frequent audits.

General description

flowIQ® 4200 is a hermetically sealed water meter intended for measurement of cold water consumption in multi-unit buildings and commercial applications.

flowIQ® 4200 employ the ultrasonic measurement principle, based on Kamstrup's experience since 1991, with the initial development and production of static ultrasonic meters.

One of flowIQ® 4200's many advantages is the fact that it has no wearing parts, which ensures a high and stable accuracy throughout its lifetime. flowIQ® 4200 complies with all the AWWA C715-18 guideline for Ultrasonic Water Meters.

In the flowIQ® 4200 series a composite housing is mounted on a stainless steel meter body with coated split flanges in cast iron. The electronics are fully protected against internal or external penetration of water.

The meter is suitable for mounting in pump stations or wellheads, as it will also function in fully submerged conditions.

flowIQ® 4200 measures the water consumption electronically, as a volume, using two pairs of ultrasonic signals. Through four ultrasonic transducers, an ultrasonic signal is sent with and against the flow direction. A transducer serves both as a 'speaker' when transmitting and as a 'microphone' when a signal is received. The ultrasonic signal traveling with the flow will be the first to reach the opposite transducer, while the signal running against the flow will be delayed. The time difference, between the two signals, can be converted into flow velocity, and thereby also into a volume. The measuring principle is a proven, long-term stable and accurate measuring principle.

In addition to volume reading, an indication of current flow and a number of other information codes are displayed. All registers are saved daily in the meter data logger (EEPROM) and are kept for 460 days. Furthermore, monthly data for the latest 36 months, hourly data for the latest 100 days and 50 infocode events are saved.

flowIQ® 4200 is powered by 2xD-cell internal lithium batteries which can provide up to 20 years operating life.

flowIQ® 4200 is available with a choice of two integrated data communication options and can be operated in either frequency configuration:

- 912.5, 915 or 918.5 MHz – Wireless Radio version (RF) for Wireless M-Bus – US localization of European standard for remote reading of meters EN 13757-4
- 450-470 MHz is used in AMI (Fixed network)

The meter is fitted with an optical IR interface which makes it possible to read saved consumption data and info codes, stored in the meter's data logger. Using an optical IR interface, it is also possible to change the meter configuration e.g. data packages.

flowIQ® 4200 can and must only be opened by Kamstrup A/S or by Kamstrup instructed personnel in regards to battery replacement.

Technical data

Electrical data

Battery 2xD-cell batteries, 3.6V. The battery warranty does not apply at meter temperatures above $t_{BAT} > 95\text{ }^{\circ}\text{F}$. t_{BAT}

Mechanical data

Protection class IP68-rated (waterproof/submersible)
 Maximum operating pressure Round flange mounted, 275 PSI
 Ambient/meter temperature 35 °F...130 °F
 Water temperature 33 °F...120 °F
 Storage temp. empty sensor -10 °F...140 °F
 Upstream/Downstream
 Pipe Length Req. U0/D0

Accuracy

KWM4220 6" 1400 GPM

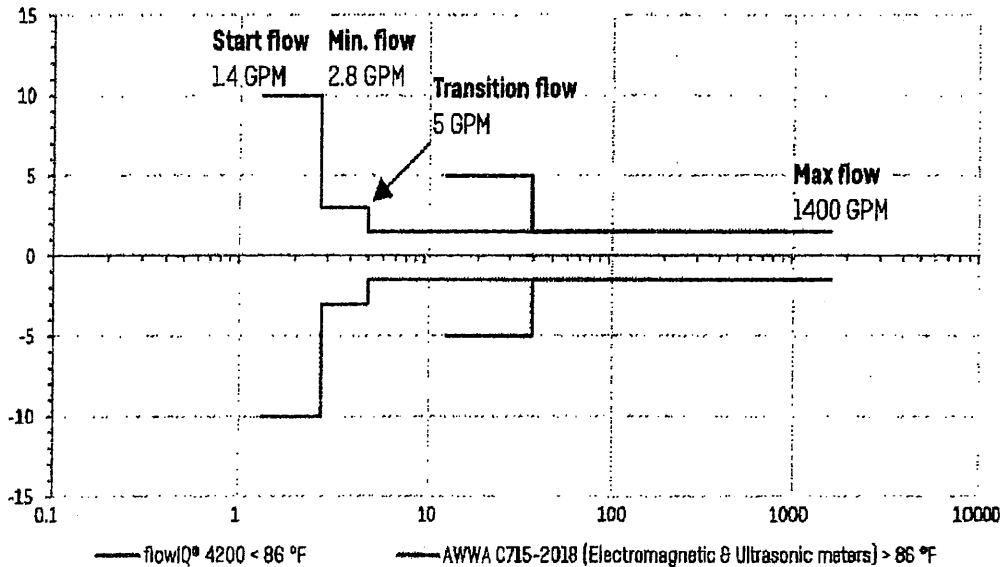

Note: At flows between 'Start flow' and 'Maximum flow' measurement occurs - however the accuracy is only guaranteed in the range from minimum flow to maximum flow.

Approvals

Certified to NSF/ANSI 61
 Complies to part 15 of the FCC rules
 Complies with AWWA C715-18 [except C708 or others if stated in the order confirmation]

Material

Wetted parts

Flow part, flanged	Stainless Steel 316L
O-ring/gasket	EPDM
Transducer pocket	PPS with fiberglass

Non-wetted parts

Split flanges	Cast iron, EN-GJS-500-7C-black-FBE coating
---------------	--

External meter parts

Meter housing	Polyphenylene sulfide (PPS) – 40 % fibreglass
Cover	Glass
Top ring (sealing)	Polycarbonate (gray)

Meter sizes

flowIQ® 4200 is available in these sizes:

Typ. number	Meter size	Start flow (S)	Max. flow	Min. flow	Transition flow	Pressure loss SMOC ³⁾	Connection on meter	Lay length	Split flange weight	Total weight
RF version	Inches	GPM	GPM	GPM	GPM	PSI		Inches	(lbs)	(lbs)
02-E-02-G-1-FR-8US ²⁾	6"	1.4	1400	2.8	5	4.2	6"	18"	31	60
02-E-02-G-1-GA-8US ²⁾	8"	1.7	2800	4	7	3.9	8"	20"	42	86
02-E-02-G-1-GJ-8US	10"	2	4500	5	8	4.2	10"	17.7"	64	134
02-E-02-G-1-GS-8US	12"	2.3	5500	6	10	2.8	12"	19.7"	84	185

¹⁾ At flows between 'Start flow' and 'Maximum flow' measurement occurs – however the accuracy is only guaranteed in the range from minimum flow to maximum flow.

²⁾ Is delivered with spool piece.

³⁾ SMOC = Safety Maximum Operating Capacity (pressure).

Meter face details

Meter information in permanent laser engraved text.

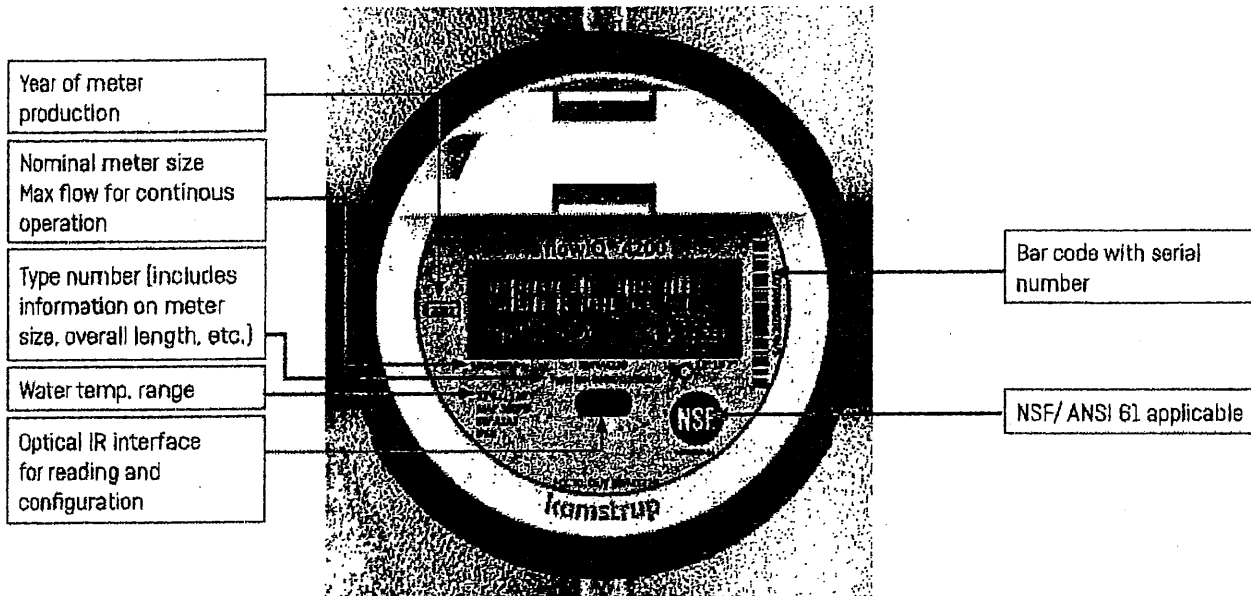

Sensor information

Water meters placed throughout the network make it possible to gather information that can be of vital importance for an effective water supply, asset management and improved customer service.

Temperature monitoring

flowIQ® 4200 measures ambient temperatures.

Information on temperatures above or below the configured temperature in the meter will warn the utility on potential frost damages or quality issues.

The measurements can be used to monitor the installation and to give an indication of the quality of the water.

Consumption above max flow

The meter logs information on consumption above max flow. This information can be used to indicate if the meter size for a given installation is correct.

Consumption histogram

The meter tracks consumptions in different flow intervals for further analysis of the consumption patterns for the specific installation.

No consumption

If no consumption has been measured for a long period of time the meter will inform the utility, as this indicates a potential problem with the installation.

Replaceable battery

The flowIQ® 4200 has two built-in D-cell lithium batteries that supply the meter, these batteries are replaceable by Kamstrup educated personnel. When replacing the battery Kamstrup's Battery replacement kit no: 6699-821 (TBD) must be utilized with the relevant replacement guide.

The battery replacement MUST be done by Kamstrup educated personnel, for information regarding warranty see terms and conditions.

Display and info codes

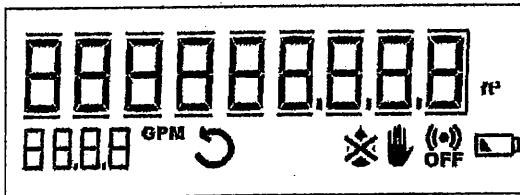

The large display of flowIQ® 4200 shows the totalized volume, flow rate and info.

An info code indicates a special condition in the meter. If the info code is available in the display, the related symbol is on when it has been activated. If the 'condition' is not active, the sign is off.

Info code	Condition
	Attempt of fraud. The meter is no longer valid for billing.
	The meter is dry. In this case nothing will be measured.
	The water flows through the meter in the wrong direction.
	RADIO OFF flashes. The meter is still in transport mode with the built-in radio transmitter turned off. The transmitter turns on automatically on the first time water runs through the meter.
	RADIO OFF lights permanently. The radio is switched off permanently. Can be activated via METERTOOL.
	The symbol appears when the expected capacity left is 6 months or less.

Data registers

The water meter has a permanent memory, in which the values of various data loggers are saved.

The loggers can be read via the meter's optical IR interface.

The following registers are logged:

Description	Yearly logger	Monthly logger	Daily logger	Hourly logger
Logger depth	20 years	36 months	480 days	2400 hours
Operating hours	✓	✓	✓	✓
Info codes incl. hour counter	✓	✓	✓	✓
Volume	✓	✓	✓	✓
Volume reverse	✓	✓	✓	✓
Volume net	✓	✓	✓	✓
Flow max year incl. Date	✓			
Flow min year incl. Date	✓			
Flow max month incl. Date		✓		
Flow min month incl. Date		✓		
Flow max day incl. Timestamp			✓	
Flow min day incl. Timestamp			✓	
Ambient temp. Max. Year	✓			
Ambient temp. Min. Year	✓			
Ambient temp. Avg. Year	✓			
Ambient temp. Max. Month		✓		
Ambient temp. Min. Month		✓		
Ambient temp. Avg. Month		✓		
Ambient temp. Max. Day			✓	
Ambient temp. Min. Day			✓	
Ambient temp. Avg. Day			✓	

Every time the information code changes, date and info codes are logged. Thus, it is possible to data read the latest 50 changes of the information code as well as the date the change was made. Reading is only possible via the optical IR interface.

Radio package options

Optional RF output

Some of the data sent via a high-power antenna and integrated 912.5, 915 or 918.5 MHz band RF is optional. It is possible to select one of the data packages with content illustrated in the figure below.

The choices are determined by means of the selected YZZZ-value when ordering a water meter – shown to the right in the figures.

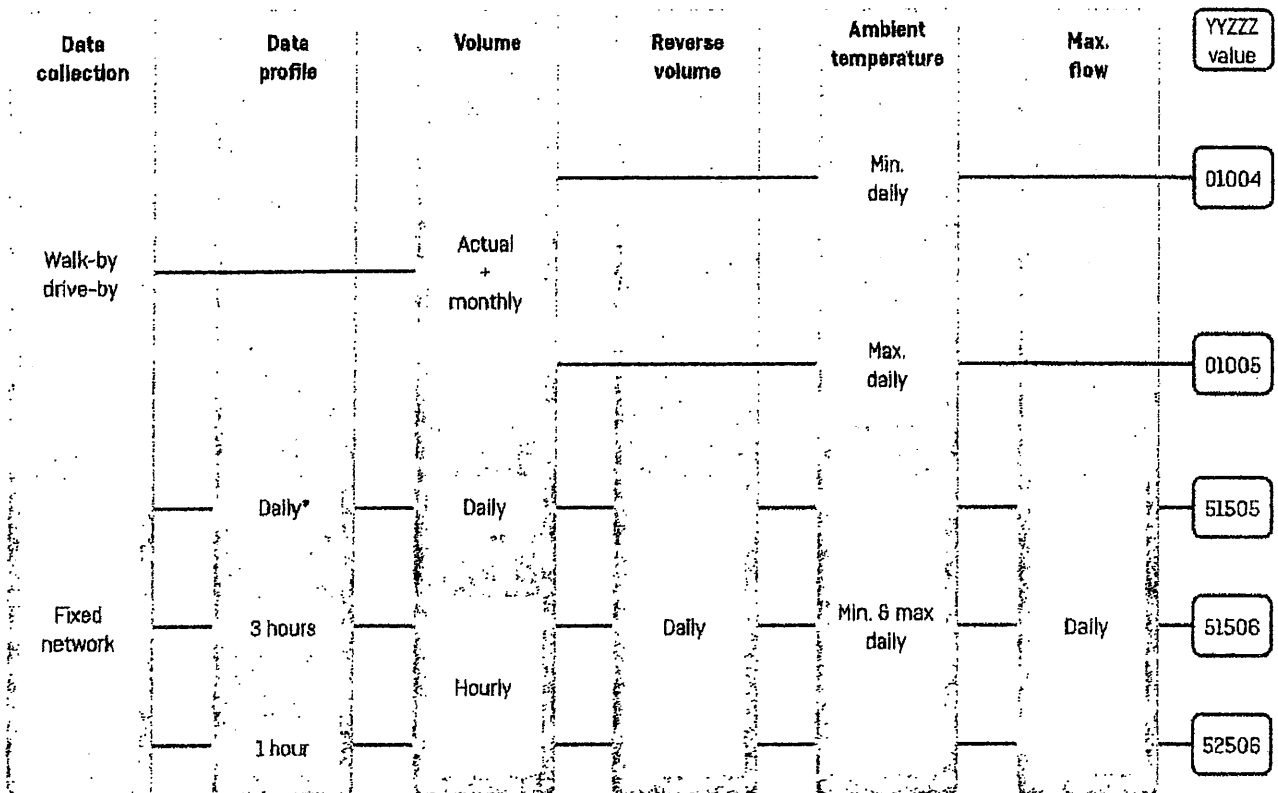

*The package is transmitted every 3 hours.

State of the art meter reading system (READy)

Standardized and open communication

902-928 MHz band RF is an open standard, following EN13757-4:2010, which means that while the flowIQ® 4200 can be configured with or without encryption of the transmitted signal, encryption is required in the United States.

Encryption protects personal data against unauthorized monitoring. Furthermore, the encryption file provides easy access to import meter data for reading programs.

Pressure loss

According to AWWA C715-18 guideline Type II (except C708 or others if stated in the order confirmation) the maximum pressure loss must not exceed 7 PSI at SMOC for water meters.

The following graph shows pressure loss with respect to flow rate:

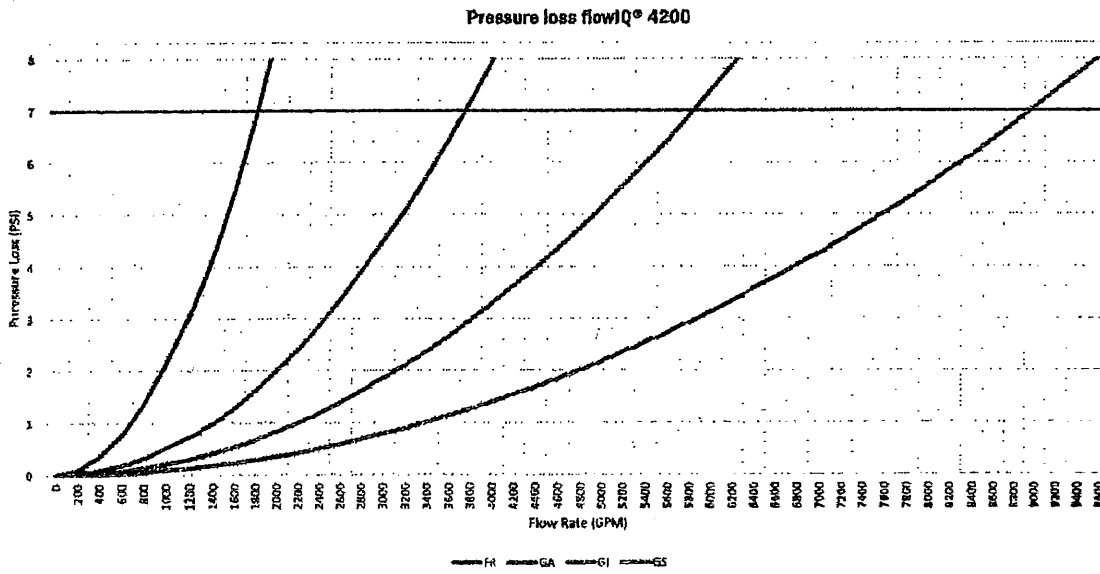

Ordering details

An order is initiated by stating the type number of the selected model of flowIQ® 4200. The type number includes information on meter type - meter version, size, lay length, service connection and time zone.

Subsequently the meter configuration, which determines customer-specific requirements such as number of digits in display etc., is selected. The configuration is completed during programming of the final meter.

Accessories are enclosed separately to be mounted by the installer.

Meter type - flowIQ® 4200

Type	□□ □ □ □ □ □ □ □ □
Meter generation	
Second generation	02
Mechanical design	
3-part stainless body and tube with iron flanges	E
Communication	
AMI, dual-band capable, (2-way)	02
Power supply	
2xD-cell	G
Dynamic range	
AWWA C715-18	1
Meter size	
6" x 18" (incl. spool piece) (1600GPM)	FR
8" x 20" (incl. spool piece) (2800 GPM)	GA
10" x 17,7" (4500 GPM)	GJ
12" x 18,7" (5500 GPM)	GS
Meter type	
Cold water	8
Country code	
North America, NSF approval	UB

The features included in the type number cannot be changed once the meter has been produced.

Configuration - flowIQ® 4200

	DDD	JJ	LLL	MMMM	N	P	S	U	RR	CCC	V	T	YY	ZZ
Config	□□□	□□	□□□	□□□□	□	□	□	□	□□	□□□	□	□	□□	□□□
Display views ¹⁾														
KWM4220		810												
GMT offset Time zone														
USA Eastern (GMT-5)		28												
USA Central (GMT-6)		24												
USA Mountain (GMT-7)		20												
USA Pacific (GMT-8)		16												
Target date (Handled as order data)														
Max values averaged over time (1.120 min.) 2 minutes			002											
Customer label Customer label blank				5000										
Leakage message limit														
OFF								0						
Pipe burst limit														
OFF								0						
Ambient Temperature low limit														
OFF								0						
Ambient temperature < 8 °C / 37 °F								3						
Ambient temperature < 6 °C / 43 °F								6						
Ambient Temperature high limit														
OFF								0						
Ambient temperature > 35 °C / 95 °F								3						
Ambient temperature > 45 °C / 122 °F								6						
Data logger profile Standard (default)										04				
Display resolution (alphanumeric)														
000000000 ft³ - 0.01 GPM - Billing in 1s													100	
000000000 ft³ - 0.01 GPM - Billing in 1,000s													150	
000000000 USgal - 0.01 GPM - Billing in 1,000s													240	
to be continued on next page														

Configuration - flowIQ® 4200

	DDD	JJ	LLL	MMMM	N	P	S	U	RR	CCC	V	T	YY	ZZZ
Config	□□□	□□	□□□	□□□□	□	□	□	□	□□	□□□	□	□	□□	□□□
...continued from previous page														
Temperature units of measure														
Fahrenheit											1			
Encryption level														
Encryption with separately forwarded key												3		
System														
AMR														01
AMI														51
AMI, no battery warranty ²⁾														52
Data packages - AMR														
Actual: Vol., Monthly: Vol., Daily: Min. ambient temp.														(01)-004
Actual: Vol., Monthly: Vol., Daily: Max ambient temp.														(01)-005
Data packages - AMI (Configurable with READY app/manager)														
Default, Daily - Vol., reverse vol., Min. ambient temp., Max flow, Max Ambient temp.														(51)-505
Default, 3 hour - Vol., reverse vol., Min. ambient temp., Max flow, Max Ambient temp.														(51)-506
Default, 1 hour - Vol., reverse vol., Min. ambient temp., Max flow, Max Ambient temp.														(52)-506

¹⁾ Volume and software version are always a part of display views
²⁾ Only for data package 506

	DDD	JJ	LLL	MMMM	N	P	S	U	RR	CCC	V	T	YY	ZZZ
Unless otherwise stated in the order, Kamstrup supplies the following:	810	□□	002	0000	0	0	3	3	04	220	1	3	01	004

Note: JJ (timezone) and target data are not predefined and has to be chosen in the ordering system.

Dimensional sketches

NOTE! Same flanges for in- and outlet

Type: FR

Size: 1600 GPM 6" x 18" (incl. spool piece)

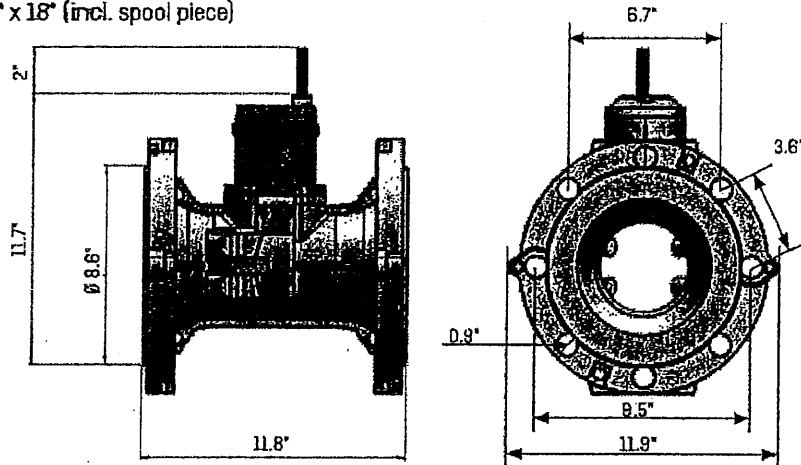

Type: GA

Size: 2800 GPM 8" x 20" (incl. spool piece)

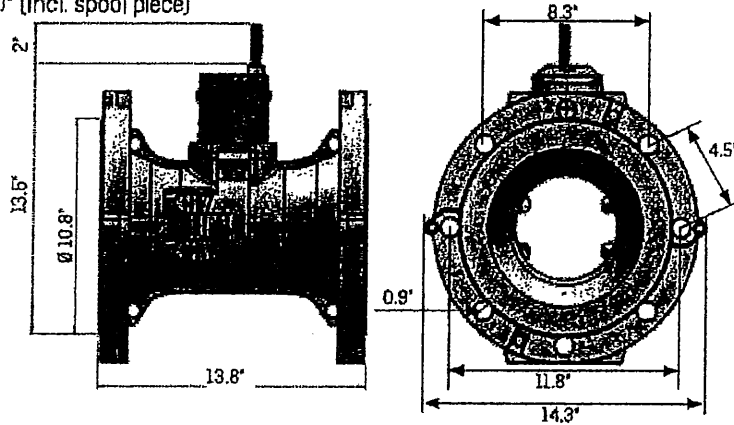

Type: GJ

Size: 4500 GPM 10" x 17"

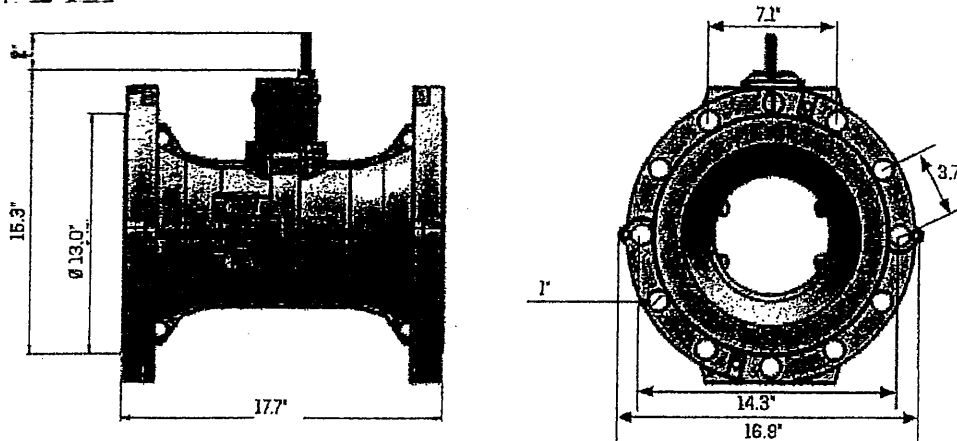

Dimensional sketches

Type: GS
Size: 5500 GPM 12" x 19.7"

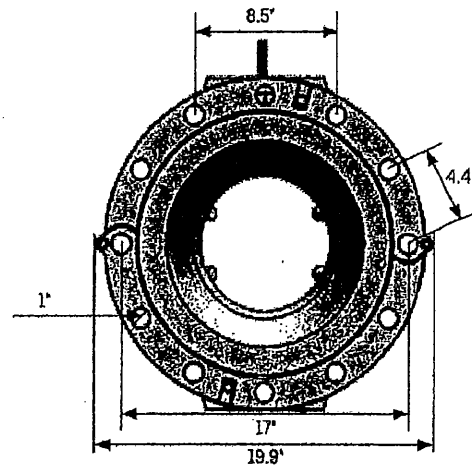
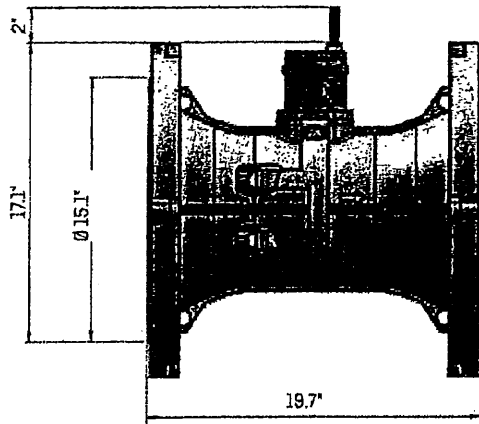

Spool piece for 6" (FR)
6.08"

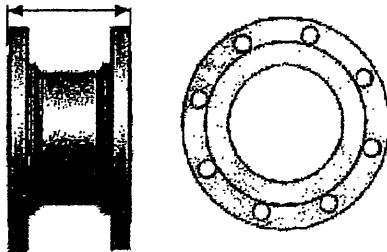

Spool piece for 8" (GA)
6.12"

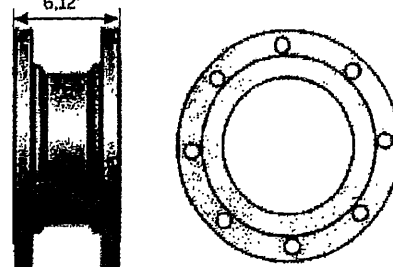

flowIQ® 4200

Accessories

See Accessories for Water Meters: 58101743 US.

(Accessories are ordered separately in CPQ (Kamstrup ordering system) and will be delivered as single parts in the packaging.)

Kamstrup A/S - 58101925_AL_EN-US_09.2022

Kamstrup Water Metering, LLC
245 Hembree Park Drive, Ste. 110
Roswell, GA 30076, USA
T: +1 (404) 835-6716
info-us@kamstrup.com
kamstrup.com

CODE: 13-228 City Clerk – Books & Supplements

SECTION 56-6

Bid2024-090 Code of Ordinance Annual Web Hosting & Administrative Fees

Municipal Code Corporation
PO Box 2235
Tallahassee, FL 32316

Contract Award: \$6,650.00

Contract Period: July 1, 2023 – June 30, 2024



CITY OF WARWICK
OFFICE OF THE CITY CLERK
3275 POST ROAD
WARWICK, RHODE ISLAND 02886
TEL. (401) 738-2006
FAX (401) 732-7640

Frank J. Picozzi
MAYOR

Lynn D'Abrosca
City Clerk

To: Francis Gomez – Purchasing Agent
From: Lynn D'Abrosca – City Clerk
Date: June 27, 2023
RE: 56-6 EXCEPTION TO PUBLICATION

This is a request for funds for the Code of Ordinances and to cover the annual web hosting. This supplement will cover any ordinances that have been passed by the City Council since the beginning of the fiscal year. I would request that \$6650.00 be awarded. The funds will be taken from 13-228.

Please consider this memo a request for an exception to publication under 56-6 of the Warwick Code of Ordinances. Municipal Code Corporation is the recommended vendor for this award as it would be a disadvantage to the City for this to go out to bid.

The funds will be encumbered on an as needed basis. On average there are 2 to 3 supplements per year. Annual Web hosting and administrative support fees are \$1375.00. This is a guaranteed price through fiscal year 2024. Supplements are \$18.94 per page, not inclusive of graphs, tabs, shipping and tax. As such, the supplement costs can only be estimated as they will vary due to size and needed graphs and tabs and applicable shipping and tax.

Note: This bid is for FY 2024 - 7-1-2023 through 6-30-2024, the funds will be in the under budget code 13-228. The current bid expires 6/30/23

CODE: 33-355 Police Grants – RI State JAG 2020

SECTION 6-12

Request permission to increase PCR-49-23 (Sub A) from \$16,738.00 to \$21,386.00.

Bid2024-015 Purchase SWAT Team Headsets with Mounting Hardware

Surplus Provisions, LLC
721 Pontiac Ave.
Cranston, RI 02910

LAST ACTION TAKEN

Award (Bid): PCR-49-23 (Sub A) approved on May 8, 2023 in the amount of \$16,738.00. Contract award is for a one-time purchase.

Contract Increase Requested:	\$4,648.00
Current Contract Award:	\$16,738.00
Contract Period Requested	No Change in Contract Period
Current Contract Period	One-Time Purchase

CITY OF WARWICK

Bradford E. Connor
Chief of Police

Frank J. Picozzi
Mayor



JUN 16 2023

Police Department
99 Veterans Memorial Drive
Warwick, Rhode Island 02886-4617
Telephone: (401) 468-4200

June 14, 2023

Ms. Francis Gomez, Purchasing Agent
Warwick City Hall
3275 Post Road
Warwick, RI 02886

Re: Bid2024-015 Purchase SWAT Team Headsets with Mounting Hardware
6-12 Alteration to contract
Funding Source: 2020 Justice Assistance Grant (JAG)

Dear Ms. Gomez,

The police department's bid to purchase SWAT team headsets with mounting hardware was previously approved and Surplus Provisions, LLC was awarded the \$16,738 bid funded through the 2022 Justice Assistance Grant (JAG).

The Police Department is requesting an additional \$4,648.00 in spending authority, funded through the department's 2020 Justice Assistance Grant (JAG), to purchase several more headsets.

If approved, the police department's SWAT team would implement these additional headset communications which will equip at least four (4) more SWAT team members. These communication headsets mount to the SWAT team members' tactical helmets and allow for communication between SWAT members during an operation. Communications is a key element to a successful & safe outcome for what are often very dynamic operations. These modern headsets provide also for "push-to-talk" capabilities. This allows other SWAT team personnel not directly involved in an operation to communicate with those that are via a cellphone.

The department is requesting permission to spend up to \$4,648.00 for this award increase. Funding for purchases with this increased amount will be allocated from the department's 2020 Justice Assistance Grant (JAG). This is a one-time purchase.

Please feel free to contact me should you need any further information.

Sincerely,

Major Andrew P Sullivan
Administrative Bureau Commander

CITY OF WARWICK

STATE OF RHODE ISLAND

RESOLUTION OF THE CITY COUNCIL

05/08/2023

MEETING DATE: _____

NO: R-23-43

APPROVED: *[Signature]* MAYOR

DATE: 5-8-23

RESOLVED, That The City Council of the City of Warwick as required by the provisions of Sections 6-11 and 6-12 of the City Charter and the Ordinance relative to competitive bidding on purchase enacted there under hereby and herewith approves the acceptance of the following bid(s):

Bid #	Name	Vendor(s) Name/Address	Contract Award	Contract Period	Note	Code
2023 - 395	Pontiac Village Park Site Improvements	<i>YardWorks, Inc.</i> 1309 Warwick Ave. Warwick, RI 02888	\$274,400.00	One Year from Date of Award		
2023 - 439	GIS & Asset Management Services	<i>Beta Group, Inc.</i> 701 George Washington Highway Lincoln, RI 02865	\$207,972.00			56 - 6
2023 - 412	MDR/EDR Service Solution	<i>ConnectWise LLC</i> 400 N Tampa St. Suite 130 Tampa, FL 33602	\$94,374.72	Three Years from Date of Award		

Continued next page

Bid #	Name	Vendor(s) Name/Address	Contract Award	Contract Period	Note	Code
2024 - 031A	Pipe Fittings & Valves	Warwick Winwater Company 62 Wyoming Ave. Warwick, RI 02888 Ferguson Waterworks 2 Whitman Road Canton, MA 02021 John Hoadley & Sons, Inc. 672 Union St. Rockland, MA 02370 EJ Prescott Inc. 38 Albion Road Lincoln, RI 02865 Lindon Group, Inc. 310 Bovine Ave. Bldg. 67F Rumford, RI 02916	\$50,000.00 (inclusive of Bid2024-031 A & B)	7/25/2023 - 1/20/2024		
2024 - 031B	Pipe Fittings & Valves – Additional Vendors	Core & Main Jack Farrelly Co. Putnam Pipe Co. Radians Stiles, Inc. Ti-Sales, Inc.	\$50,000.00 (inclusive of Bid2024-031 A & B)	7/25/2023 - 01/20/2024		56 - 6
2023 - 442	Purchase New 2023 Ford Police Utility Vehicle	Colonial Municipal Group 40 Holman Road Plymouth, MA 02360	\$46,835.40			56 - 6
2023 - 407	Purchase Redundant Firewalls	443 Technologies 4 Research Dr. Suite 402 Shelton, CT 06484	\$44,019.00	Three Years from Date of Award		
2023 - 338	Hazard Mitigation Plan Update	VHB 1 Cedar Street, Suite 400 Providence, RI 02903	\$32,000.00	Two Years from Date of Award		

Continued next page

COPY

PCR-49-23 (Sub A)

Bid #	Name	Vendor(s) Name/Address	Contract Award	Contract Period	Note	Code
2023 - 444	Furnish & Install HVAC Controllers at Animal Shelter	<i>D. Larsen & Son</i> 110A Byfield Street Warwick, RI 02888	\$21,475.00			56 - 6
2024 - 025	Janitorial & Cleaning Supplies for Fire Department	<i>WB Mason Co., Inc.</i> 99 Bald Hill Rd. Cranston, RI 02920 <i>Likarr, Inc.</i> 6 Perry Drive Foxboro, MA 02035	\$20,000.00	7/1/2023 - 6/30/2024		
2024 - 015	Purchase SWAT Team Headsets with Mounting Hardware	<i>Surplus Provisions, LLC</i> 721 Pontiac Ave. Cranston, RI 02910	\$16,738.00			
2022 - 286B	City of Warwick (District 6) Gasoline, Low Sulfur Diesel, and Ultra Low Sulfur Diesel Fuel	<i>Santa Buckley Energy</i> 154 Admiral Street Bridgeport, CT 06601	\$13,522.31		1	6 - 12
2024 - 017	Animal Shelter Food & Cat Litter	<i>Pet Supplies Plus</i> 171 Sockanosset Crossroad Cranston, RI 02920	\$12,000.00	7/1/2023 - 6/30/2025		
2023 - 438	Replace Doors & Additional Post at Thayer Arena	<i>New England School Services, Inc.</i> 98 Hicks Ave. Medford, MA 02155	\$10,792.00			56 - 6
2023 - 419	Acoustic Wall & Ceiling Panels for Interview Room RE-BID	<i>Vibrasciences Inc.</i> 186 N. Main St. Branford, CT 06405	\$10,519.00			

★

Continued next page

Bid #	Name	Vendor(s) Name/Address	Contract Award	Contract Period	Note	Code
2024 - 009D	Quarterly Fire Alarm Inspections & Testing	<i>Precision Alarm Corp.</i> 14 Wakefield St. West Warwick, RI 02893	\$10,000.00	7/12/2023 - 7/11/2024		
2024 - 024	Fire Sprinkler Inspections & Repair for Fire Stations 1, 8, and 10	<i>Johnson Controls, Inc.</i> 6 Blackstone Valley Place Lincoln, RI 02865	\$10,000.00	7/1/2023 - 6/30/2025		
2023 - 417	Purchase One Shipping Storage Container for Police Range	<i>Outback Storage</i> 11 Gavitt Ave. Westerly, RI 02891	\$7,245.00	7/1/2023 - 6/30/2024		

Continued next page

Bid #	Name	Vendor(s) Name/Address	Contract Award	Contract Period	Note	Code
2023 - 073	Workstations, Laptops, Tablets, Printers, Copiers, and Computer Peripherals	<p>Xavus Solutions PO Box 55071 #30713 Boston, MA 02205-5071</p> <p>CDW Government LLC 300N Milwaukee Ave. Vernon Hills, IL 60061</p> <p>HP INC PO Box 101149 Atlanta, GA 30392</p> <p>Whalley Computer Associates Inc. 9 Industrial Rd. Milford, MA 01757</p> <p>GovConnection Inc. 732 Milford Rd. Merrimack, NH 03054</p> <p>Staples 1901 Summit Tower Blvd. Orlando, FL 32810</p> <p>W.B. Mason Co. Inc. 99 Bald Hill Rd. Cranston, RI 02920</p> <p>Amazon 410 Terry Ave. North Seattle, WA 98109</p> <p>Custom Computer Specialist Inc 70 Suffolk Court Hauppauge, NY 11788</p> <p>Easy Workforce Software 3141 Commerce Parkway Miramar, FL 33025</p>	\$6,300.00		2	6 - 12
2024 - 021	Blood Borne Pathogen & Narcotics Remediation	<p>New England Trauma Services, LLC 391 Oakland St. Mansfield, MA 02048</p>	\$6,000.00	7/1/2023 - 6/30/2024		

Continued next page

Bid #	Name	Vendor(s) Name/Address	Contract Award	Contract Period	Note	Code
2024 - 022	BCI Photography & Printing Supplies	<i>WB Hunt Co., Inc. Dba Hunt's Photo & Video 100 Main St. Melrose, MA 02176</i>	\$5,000.00	7/1/2023 - 6/30/2024		
2024 - 023	BCI Crime Scene Supplies	<i>Sirchie Acquisition Company, LLC 100 Hunter Place Youngsville, NC 27596</i>	\$5,000.00	7/1/2023 - 6/30/2024		
2024 - 026	Structural Firefighting Gloves	<i>Fire Tech & Safety of New England 100 Business Park Dr. Tyngsborough, MA 01879</i>	\$5,000.00	7/1/2023 - 6/30/2024		
2023 - 432	SolarWinds Additional Polling Engine	<i>SHI International Corp. 290 Davidson Ave. Somerset, NJ 08873</i>	\$4,730.52	6/27/2023 - 6/26/2024	3	56 - 10
2023 - 420	Purchase Harley Davidson Cool Flow Fans	<i>Russ' Ocean State Inc. Dba Russ's Ocean State Harley Davidson 35 Albany Road Warwick, RI 02888</i>	\$4,413.62			
2022 - 389	Buckeye Brook Restoration Projects	<i>Cardi Corporation 400 Lincoln Ave. Warwick, RI 0288</i>	No Monies Requested	5/25/2023 - 9/25/2023	4	6 - 12
2024 - 028	Hoxsie School Basketball Courts	<i>Narragansett Improvement Co. 223 Allens Ave. Providence, RI 02903</i>	\$71,092.50	One Year from Date of Award		

Continued next page

Bid #	Name	Vendor(s) Name/Address	Contract Award	Contract Period	Note	Code
2023 - 455	Purchase 8 Solar Speed Signs	<i>All Traffic Solutions, Inc.</i> 14201 Sullyfield Circle, Suite 300 Chantilly, VA 20151	\$28,976.00			56 - 6
2023 - 454	Purchase (2) 30-Yard Roll-Off Containers	<i>RI Container Products</i> 175 Shun Pike Johnston, RI 02919	\$13,200.00			56 - 6
2023 - 450	Software for Fuel Dispensing System	<i>Multiforce Systems Inc.</i> 101 Wall St. Princeton, NJ 08540	\$4,410.00	One Year from Date of Award		56 - 6
2023 - 453	Purchase 2023 Chevrolet Trailblazer AWD LT	<i>Colonial Municipal Group</i> 61 Camelot Drive Plymouth, MA 02360	\$31,933.00			56 - 6
2023 - 441	Installation & Maintenance of West Shore Road Buffer Planting	<i>Green View Tree Service</i> 109 Fletcher Ave. Cranston, RI 02920	\$29,420.00	One Year from Date of Award		56 - 6

AND BE IT FURTHER RESOLVED, That such purchase or contract be awarded to the lowest responsible bidder.

1. Request permission to increase PCR-140-22 (Sub A) from \$270,000.00 to \$283,522.31.
2. Request permission to increase PCR-37-23 (Sub A) from \$123,556.08 to \$129,856.08.
3. Request permission to piggyback state MPA #517.
4. Request permission to extend expiration date of PCR-62-22 (Sub A) from May 25, 2023 to September 25, 2023.

Continued next page

COPY

PCR-49-23 (Sub A)

Actions Taken:

Bid2024-027 ADA Improvements at Crosswalks

PCR-52-23 (Sub A)
Amended Bid number
from 2024-029 to
2024-027

THIS RESOLUTION SHALL TAKE EFFECT UPON ITS PASSAGE

Bid2024-015 Purchase SWAT Team Headsets with Mounting Hardware

- 2 bids received

CODE: 33-350 Police Grants – RI State JAG 2022

MANNER OF AWARD: \$16,738.00
One-Time Purchase

RECOMMEND: Surplus Provisions, LLC

Surplus Provisions LLC
721 Pontiac Ave.
Cranston, RI 02910

Atlantic Tactical, Inc.
763 Corporate Circle
New Cumberland, PA 17070

Item #	Description	Surplus Provisions Bid (Price per one unit)	Atlantic Tactical Bid (Price per one unit)
1.	TCI Liberator IV Headset & PTT Single Comm. System w/ Helmet Mount, Black	\$1,095.00	\$1,259.03
2.	Push to Talk Systems	\$0.00 (see note 1)	Included in item #1
3.	Upgraded Alpha PTT	\$235.00 (see note 2)	Included in item #1
4.	Helmet Mounts, Black	\$135.00	Included in item #1

Notes:

1. Item #2 is included in price of items #1 & #3.
2. Item #3 is for upgraded Alpha PTT only. Total price of Liberator IV Headset with Helmet Mount w/ Alpha PTT equals item #1 plus item #3, or \$1,330.00.

CITY OF WARWICK

APR 24 2023

Bradford E. Connor
Chief of Police

Frank J. Picozzi
Mayor



Police Department
99 Veterans Memorial Drive
Warwick, Rhode Island 02886-4617
Telephone: (401) 468-4200

April 18, 2023

Ms. Francis Gomez, Purchasing Agent
Warwick City Hall
3275 Post Road
Warwick, RI 02886

Re: Bid Recommendation – Police Department
Bid2024-015 Purchase SWAT Team Headsets with Mounting Hardware
Funding Source: 2022 Justice Assistance Grant (JAG)

Dear Ms. Gomez,

The department received two (2) bids for Bid2024-015, "Purchase SWAT Team Headsets with Mounting Hardware." The bids were received from the following vendors:

1. Surplus Provisions, LLC of 721 Pontiac Avenue Cranston, RI 02910
2. Atlantic Tactical, Inc of 763 Corporate Circle New Cumberland, PA 17070

The Police Department recommends Surplus Provisions be awarded the bid as they were the lowest overall qualified bidder.

If approved, the police department's SWAT team would implement headset communications. These communication headsets mount to the SWAT team members' tactical helmets and allow for communication between SWAT members during an operation. Communications is a key element to a successful & safe outcome for what are often very dynamic operations. These modern headsets provide also for "push-to-talk" capabilities. This allows other SWAT team personnel not directly involved in an operation to communicate with those that are via a cellphone.

The department is requesting permission to spend up to \$16,738 for this award. Funding for purchases under this bid will be allocated from the department's 2022 Justice Assistance Grant (JAG). This is a one-time purchase.

Please feel free to contact me should you need any further information.

Sincerely,

A handwritten signature in black ink, appearing to read "Andrew P Sullivan".

Major Andrew P Sullivan
Administrative Bureau Commander

✓ Award Letter

September 26, 2022

Dear Nicholas Reay,

On behalf of Attorney General Merrick B. Garland, it is my pleasure to inform you the Office of Justice Programs (OJP) has approved the application submitted by WARWICK, CITY OF for an award under the funding opportunity entitled 2022 BJA FY 22 Edward Byrne Memorial Justice Assistance Grant Program - Local Solicitation. The approved award amount is \$16,738.

Review the Award Instrument below carefully and familiarize yourself with all conditions and requirements before accepting your award. The Award Instrument includes the Award Offer (Award Information, Project Information, Financial Information, and Award Conditions) and Award Acceptance. For COPS Office and OVW funding the Award Offer also includes any Other Award Documents.

Please note that award requirements include not only the conditions and limitations set forth in the Award Offer, but also compliance with assurances and certifications that relate to conduct during the period of performance for the award. These requirements encompass financial, administrative, and programmatic matters, as well as other important matters (e.g., specific restrictions on use of funds). Therefore, all key staff should receive the award conditions, the assurances and certifications, and the application as approved by OJP, so that they understand the award requirements. Information on all pertinent award requirements also must be provided to any subrecipient of the award.

Should you accept the award and then fail to comply with an award requirement, DOJ will pursue appropriate remedies for non-compliance, which may include termination of the award and/or a requirement to repay award funds.

Prior to accepting the award, your Entity Administrator must assign a Financial Manager, Grant Award Administrator, and Authorized Representative(s) in the Justice Grants System (JustGrants). The Entity Administrator will need to ensure the assigned Authorized Representative(s) is current and has the legal authority to accept awards and bind the entity to the award terms and conditions. To accept the award, the Authorized Representative(s) must accept all parts of the Award Offer in the Justice Grants System (JustGrants), including by executing the required declaration and certification, within 45 days from the award date.

To access your funds, you will need to enroll in the Automated Standard Application for Payments (ASAP) system, if you haven't already completed the enrollment process in ASAP. The Entity Administrator should have already received an email from ASAP to initiate this process.

Congratulations, and we look forward to working with you.

Maureen Henneberg
Deputy Assistant Attorney General

Office for Civil Rights Notice for All Recipients

The Office for Civil Rights (OCR), Office of Justice Programs (OJP), U.S. Department of Justice (DOJ) has been delegated the responsibility for ensuring that recipients of federal financial assistance from the OJP, the Office of Community Oriented Policing Services (COPS), and the Office on Violence Against Women (OVW) are not engaged in discrimination prohibited by law. Several federal civil rights laws, such as Title VI of the Civil Rights Act of 1964 and Section 504 of the Rehabilitation Act of 1973, require recipients of federal financial assistance to give assurances that they will comply with those laws. Taken together, these civil rights laws prohibit recipients of federal financial assistance from discriminating in services and employment because of race, color, national origin, religion, disability, sex, and, for grants authorized under the Violence Against Women Act, sexual orientation and gender identity. Recipients are also prohibited from discriminating in services because of age. For a complete review of these civil rights laws and nondiscrimination requirements, in connection with DOJ awards, see <https://ojp.gov/funding/Explore/LegalOverview/CivilRightsRequirements.htm>.

Under the delegation of authority, the OCR investigates allegations of discrimination against recipients from

individuals, entities, or groups. In addition, the OCR conducts limited compliance reviews and audits based on regulatory criteria. These reviews and audits permit the OCR to evaluate whether recipients of financial assistance from the Department are providing services in a nondiscriminatory manner to their service population or have employment practices that meet equal-opportunity standards.

If you are a recipient of grant awards under the Omnibus Crime Control and Safe Streets Act or the Juvenile Justice and Delinquency Prevention Act and your agency is part of a criminal justice system, there are two additional obligations that may apply in connection with the awards: (1) complying with the regulation relating to Equal Employment Opportunity Programs (EEOs); and (2) submitting findings of discrimination to OCR. For additional information regarding the EEO requirement, see 28 CFR Part 42, subpart E, and for additional information regarding requirements when there is an adverse finding, see 28 C.F.R. §§ 42.204(c), .205(c)(5).

The OCR is available to help you and your organization meet the civil rights requirements that are associated with DOJ grant funding. If you would like the OCR to assist you in fulfilling your organization's civil rights or nondiscrimination responsibilities as a recipient of federal financial assistance, please do not hesitate to contact the OCR at askOCR@ojp.usdoj.gov.

Memorandum Regarding NEPA

NEPA Letter Type

OJP - Ongoing NEPA Compliance Incorporated into Further Developmental Stages

NEPA Letter

The Edward Byrne Memorial Justice Assistance Grant Program (JAG) allows states and local governments to support a broad range of activities to prevent and control crime and to improve the criminal justice system, some of which could have environmental impacts. All recipients of JAG funding must assist BJA in complying with NEPA and other related federal environmental impact analyses requirements in the use of grant funds, whether the funds are used directly by the grantee or by a subgrantee or third party. Accordingly, prior to obligating funds for any of the specified activities, the grantee must first determine if any of the specified activities will be funded by the grant.

The specified activities requiring environmental analysis are:

- a. New construction;
- b. Any renovation or remodeling of a property located in an environmentally or historically sensitive area, including properties located within a 100-year flood plain, a wetland, or habitat for endangered species, or a property listed on or eligible for listing on the National Register of Historic Places;
- c. A renovation, lease, or any proposed use of a building or facility that will either (a) result in a change in its basic prior use or (b) significantly change its size;
- d. Implementation of a new program involving the use of chemicals other than chemicals that are (a) purchased as an incidental component of a funded activity and (b) traditionally used, for example, in office, household, recreational, or education environments; and
- e. Implementation of a program relating to clandestine methamphetamine laboratory operations, including the identification, seizure, or closure of clandestine methamphetamine laboratories.

Complying with NEPA may require the preparation of an Environmental Assessment and/or an Environmental Impact Statement, as directed by BJA. Further, for programs relating to methamphetamine laboratory operations, the preparation of a detailed Mitigation Plan will be required. For more information about Mitigation Plan requirements, please see <https://www.bja.gov/Funding/nepa.html>.

NEPA Coordinator

First Name

Orbin

Middle Name

—

Last Name

Terry

- > Award Letter
- > Award Information
- > Project Information
- > Financial Information
- > Award Conditions
- ✓ Award Acceptance

Declaration and Certification to the U.S. Department of Justice as to Acceptance

By checking the declaration and certification box below, I—

A. Declare to the U.S. Department of Justice (DOJ), under penalty of perjury, that I have authority to make this declaration and certification on behalf of the applicant.

B. Certify to DOJ, under penalty of perjury, on behalf of myself and the applicant, to the best of my knowledge and belief, that the following are true as of the date of this award acceptance: (1) I have conducted or there was conducted (including by applicant's legal counsel as appropriate and made available to me) a diligent review of all terms and conditions of, and all supporting materials submitted in connection with, this award, including any assurances and certifications (including anything submitted in connection therewith by a person on behalf of the applicant before, after, or at the time of the application submission and any materials that accompany this acceptance and certification); and (2) I have the legal authority to accept this award on behalf of the applicant.

C. Accept this award on behalf of the applicant.

D. Declare the following to DOJ, under penalty of perjury, on behalf of myself and the applicant: (1) I understand that, in taking (or not taking) any action pursuant to this declaration and certification, DOJ will rely upon this declaration and certification as a material representation; and (2) I understand that any materially false, fictitious, or fraudulent information or statement in this declaration and certification (or concealment or omission of a material fact as to either) may be the subject of criminal prosecution (including under 18 U.S.C. §§ 1001 and/or 1621, and/or 34 U.S.C. §§ 10271-10273), and also may subject me and the applicant to civil penalties and administrative remedies under the federal False Claims Act (including under 31 U.S.C. §§ 3729-3730 and/or §§ 3801-3812) or otherwise.

Agency Approval

Title of Approving Official	Name of Approving Official	Signed Date And Time
Deputy Assistant Attorney General	Maureen Henneberg	9/18/22 7:06 PM

Authorized Representative

Declaration and Certification

Entity Acceptance

Title of ~~Authorized Entity~~ Official
City Treasurer

Name of Authorized Entity Official
LYNNE PRODGER

Signed Date And Time
11/4/2022 2:07 PM

<u>Bid2024-015 Purchase SWAT Team Headsets with Mounting Hardware</u>			
<u>The following vendors were sent specifications</u>			
<u>VENDOR</u>	<u>ADDRESS</u>	<u>CITY</u>	<u>STATE</u>
Atlantic Tactical, Inc.	763 Corporate Circle	New Cumberland	PA
Optics Planet, Inc.	3150 Commercial Ave	Northbrook	IL
Surplus Provision	721 Pontiac Ave.	Cranston	RI
<u>EMAILS</u>	<u>ZIP</u>		
tom.carusso@atlantictactical.com	17070		
sales@opticsplanet.com	60062		
sales@surplusprovisions.com			

CODE: 66-369 Building Maintenance – ~~Renovation~~ Projects

SECTION 56-6

Bid2024-105 Purchase Lumber for Salt Barn

Coventry Lumber
2030 Nooseneck Hill Rd.
Coventry, RI 02816

Contract Award: \$4,206.30

Contract Period: One Time Purchase



CITY OF WARWICK
DEPARTMENT OF PUBLIC WORKS
925 SANDY LANE • WARWICK, RHODE ISLAND 02889
TEL (401) 738-2003 • FAX (401) 732-5208

FRANK J. PICOZZI
MAYOR

ERIC J. EARLS, PE
DIRECTOR OF PUBLIC WORKS

To: Francis Gomez, Purchasing Agent

From: Eric J. Earls, Director of Public Works *EJE*

Date: June 29, 2023

Subj: Coventry Lumber

This department is requesting an Exception to Notice for Coventry Lumber to purchase lumber for the newly installed salt barn in the DPW yard. It is highly recommended by the company that installed this unit to reinforce the walls with plywood above the cement blocks to insure the integrity of the walls should the stored materials breach above the blocks and to protect it from damage should a machine move too close to the walls. This unit cost the City \$226,000 and this department finds this nominal amount for lumber a solid investment to maintaining the integrity of the structure for years to come. This department is also required to maintain a covering over the salt pile in accordance with the RIDEM MS4 permit issued to the City.

Please consider this memo a request for an exception to notice under Sec. 56-6 of the Warwick Code for Coventry Lumber in the amount of \$4,206.30 to purchase the lumber materials required for this project. This is a one-time fee and therefore no contract period is necessary.

(66-369 - \$4,206.30)



Coventry Lumber
 2030 Nooseneck Hill Rd
 Coventry, Rhode Island 02816
 Phone: 401-821-2800

Quotation

Quote No 282825
Quote Date 06/28/2023

Invoice Address
 City Of Warwick
 Purchasing Division City Hall
 3275 Post Road
 Warwick, RI, 02886

Delivery Address
 City Of Warwick
 925 Sandy Lane
 Warwick, Rhode Island, 02889

Customer 005616
Your Ref 925 Sandy Lane
Delivery On 06/28/2023
Taken By Timothy Blake
Sales Rep Cory Bates



Special Instructions	Notes

Line	Product Code	Description	Qty/Footage	Price	Per	Total
1	12CDXPT	4X8' 1/2" PRESSURE TREATED CDX PLY MCA GC	75 SH	43.37	SH	3,252.75
2	248PT	2X4X8 #1 PRIME WAX MCA Pressure Treated Ground Contact	110 PC	6.87	PC	755.70
3	MC9	5/32" x 5 1/2" Tapper Drill Bit	12 ea	6.99	ea	83.88
4	MC9	3/16 x 3 3/4" Tapper+ 100 Ct Box	3 ea	37.99	ea	113.97

Before accepting the estimate, please be sure to review for accuracy. Final dollar amounts represent only material listed and will be final upon submission. Finetco is not responsible for shortages, errors, and or omissions of material that is not shown. Structural integrity and conformance are the responsibility of the customers. All prices valid through the Thursday following the date of this quotation.

Total Amount	\$4,206.30
Sales Tax	\$0.00
Quotation Total	\$4,206.30

Special Order Products are NOT returnable. All material must be verified, approved and a signed release is required by the customer before ordering. If a special order product is verified and ordered by Finetco for the customer, the customer is obligated to purchase all material on that order. When ordering a special order product it will be invoiced on delivery or no later than 30 days following Finetco's receipt of materials. ALL material must be delivered within 90days of receipt at Finetco. If the material is held longer than 90 days it will be subject to storage and disposal fees. Please sign the following as

By your signature below, you are agreeing to the Terms and Conditions set forth on back or attached.

 Buyer Date

Scan for Survey



CODE: 78-205 Postage

SECTION 56-6

Bid2024-106 Maintenance Agreement for Mail Machine

Pitney Bowes
PO Box 981022
Boston, MA 02298

Contract Award: \$3,908.04

Contract Period: September 30, 2023 – September 29, 2024

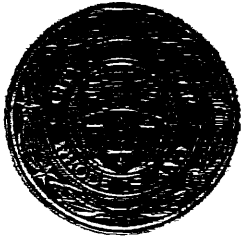

CITY OF WARWICK
DEPARTMENT OF PUBLIC WORKS
925 SANDY LANE • WARWICK, RHODE ISLAND 02889
TEL (401) 738-2003 • FAX (401) 732-5208

FRANK J. PICOZZI
MAYOR

ERIC J. EARLS, PE
DIRECTOR OF PUBLIC WORKS

To: Francis Gomez, Purchasing Agent

From: Eric J. Earls, Director of Public Works *EJE*

Date: June 29, 2023

Subj: Pitney Bowes

This department is responsible for the mail that is sent from the City through the United States Postal Service. Five years ago, in July 2018, this department received approval to enter into a five year lease of the mail machine with Pitney Bowes that is soon coming to an end. The cost for this term was \$50,835.60 under a NJPA (currently Sourcewell) government contract. At the end of the lease term, the City retains ownership of the mail equipment. This request is for an annual service agreement to cover equipment issues, particularly preventative maintenance, parts and labor. As it is Pitney Bowes equipment, this department is requesting a contract with this vendor. Also, should the City bid for a new contract and equipment, the cost will be equal to or more than the lease term that is ending, making this the most economical option.

Please consider this memo a request for an exception to notice under Sec. 56-6 of the Warwick Code for Pitney Bowes in the amount of \$3,908.04 for a one year maintenance agreement with Pitney Bowes, commencing from date of award.

(78-205 - \$3,908.04)



pitney bowes

PRICE QUOTATIONS ON MAINTENANCE AGREEMENTS AND POSTAGE METER RENTAL CONTRACTS

****THIS IS NOT A BILL!****

6/27/2023

CITY OF WARWICK CITY HALL
3275 POST RD
WARWICK, RI 02886-7191

Dear Valued Customer:

Please accept this as a written confirmation of our current Annual Maintenance Pricing
This price is only for the models and serial numbers of equipment indicated below and is contingent upon either current active SLA coverage or inspection and repair by Pitney Bowes.

The following price quote(s) are for an Annual agreement price billed: Annually 09/30/2023-9/29/2024
Install Account Number: 0011946981

Table with 4 columns: Model, Serial #, Description, Program ID. Rows include MSF6, MPR1, MSD2, 1E02, MSPS, 1E28 with their respective serial numbers and descriptions.

Annual Total: \$3,908.04

Quoted amounts do not include any applicable state or local taxes.

Inspection and repair of the equipment by Pitney Bowes prior to SLA coverage is paid by you.

Reminder: Account Number and Serial Number must be included on your Purchase Order

Thank you for doing business with Pitney Bowes.

Moretti Christy L

From: Pitney Bowes Support Email <supportemail@pb.com>
Sent: Thursday, June 15, 2023 9:42 AM
To: Moretti Christy L
Subject: [EXT] - Case#: 35245327



Hi Christy,
Your lease runs through 09/29/2023; at that point it will end and you will own the equipment.

Since you cannot own a meter chip (inside the machine), a rental for that piece will commence 09/30/2023.

I am sending off a quote request for an SLA on the to-be-owned at end of lease hardware.

Kind Regards,
Tom - Client Service

Email Thread ID [ref:_00D80KkyB._500Hn1aGLbN:ref]



Pitney Bowes Customer Technical Support

Count on our team of certified technicians to help prevent problems and quickly resolve any issues. Flexible service options integrate maintenance, technical support and systems monitoring to support your business needs.

Standard SLA

Service Contracts provide access to factory-trained technicians with skills, experience, insight, and **ability** to advise or perform any necessary maintenance for your product.

Pitney Bowes is at the ready to provide the technical and operational expertise needed to help you get peak performance and optimal value from your Pitney Bowes solution.

We offer two service offerings for nearly every serialized piece of hardware from Pitney Bowes. A **Standard Service Level (SLA)** agreement is available in nearly every geographic location in North America, and we offer a **Performance Service Level Agreement** for select products and select geographic locations. Please contact your local Pitney Bowes Sales Representative for details on available Performance SLAs.

Clients with or without a service contract can resolve many common issues or technical questions by visiting our product support web page <https://www.pitneybowes.com/us/support.html>.

Remote Product Support

We have several methods to reach us for support. Please have your product model and serial number ready to help direct your inquiry to the correct team. The remote support agent can determine if your solution is covered by a service contract and provide a quote for support options if you do not currently have coverage. There is no limit on the number of contacts a client can make for support. All channels of support for North America are available in English and French-Canadian languages.

By Phone Hardware Support: **844 256 6444** Software & Intelligent Locker Support: **800 888 0286**



Our automated voice message system is live 24-hours a day. You can hear account balance information and recent account activity. You can also listen to easy instructions for finding answers to your questions on our Support site. *Remote support Representatives are available Monday through Friday between 8am and 8pm ET, excluding holidays.

Our goal is to answer the phone within 60 seconds.

By Chat



You can locate a link to open a chat session directly from the web support page for every product. Please have your model and serial number available so the chatbot or agent can locate your account information. PB's chatbot service can answer many product questions and is available 24 hours a day.

*Live chat may be available for select products Monday through Friday between 8am and 8pm ET, excluding holidays.

Our goal is to respond to a live chat request within 30 seconds.

Create a Case



The feature Create a Case allows you to make your own support requests. Submit questions about your account, billing, make a service request for technical support, or view your cases anytime.

Note: You must first create a profile to access case management online. Once you submit your case, you will receive a confirmation number, and a Pitney Bowes representative will be in contact within 60 seconds.

**Normal Business Hours for remote support are Monday through Friday between 8am and 8pm ET, excluding holidays.*

Onsite Field Support

Our remote support agents will make every effort to resolve technical issues via your preferred **contact method**.

When efforts exceed 60 minutes to resolve remotely, our support effort will generally result in the need to dispatch a service technician to a client location. Our goal is to meet the onsite response time for the level of offering and the coinciding zone based on the service contract.

Our SLA offering availability for field support from our certified technicians is zoned based. Details are outlined below:

Zone	Standard SLA			Performance SLA 8 Hour / 4 hour
	Metro	Urban	Rural	*Metro & Urban only
Onsite Response Time Goal	8 business hours	12 business hours	24 business hours	8 or 4 hours guaranteed

*In specific geographical areas only, postal code-based eligibility. Please contact your local Pitney Bowes Sales representative to determine your zone and available Performance SLA options.

For a client in Metro area, with a **Standard SLA** contract, we will strive to have a service technician onsite within 8 business hours from the point of dispatch. This is considered an escalation to the field service team for onsite support.

For a client in Urban area, with a **Standard SLA** contract, we will strive to have a service technician onsite within 12 business hours from the point of dispatch. This is considered an escalation to the field service team for onsite support.

For a client in Rural area, with a **Standard SLA** contract, we will strive to have a service technician onsite within 24 business hours from the point of dispatch. This is considered an escalation to the field service team for onsite support.

For a client in with a **Performance SLA** contract, we will have a service technician onsite within 4 or 8 business hours from the point of dispatch based on the contract. This is considered an escalation to the field service team for onsite support.

For clients with no service contract, we can provide a quote for the Time (Labor) and Materials (Parts) to send a technician; the service commitment is best effort. The Technical Support Agent will provide an estimated time.

Point of Dispatch is at the end of the initial contact with the Remote Product Support agent, when it is determined onsite support is required.

Service by Replacement

In some cases, we may opt to send a replacement unit to resolve the issue with your hardware solution. The Technical Support Agent will inform you if the hardware will be serviced by replacement and provide further details to support you through the exchange process.

Additional Benefits of the Standard SLA

1. **SELF HELP.** 24/7 access to web self-help, user guides and product support articles.

2. **REMOTE TECHNICAL SUPPORT.** PB provides all technical support via chat or phone ("Remote Support") unless otherwise specified. To receive Remote Support, you will be asked for your model and serial number and any error codes to expedite the process of validating the client and coverage entitlement. The support agent will view product and case history and begin the effort to understand the technical problem. It is advised that the caller can be near the machine to help provide feedback and perform test functions to narrow down the root cause. Our goal in remote support efforts is to have the client back in operation and possibly avoid additional down time waiting for an onsite technician.

3. **ONSITE REPAIR (TRAVEL & LABOR).** Travel costs and labor are included when your products are covered under a Standard SLA contract, except for excluded circumstances. A certified technician will come to the installed location to further diagnose a technical issue with your solution. They carry the tools, test equipment and advanced product knowledge needed to get your solution operational. Our Field Service professionals will also consult and make recommendations on getting the highest value from your solution.

4. **PARTS.** Our service technicians carry vehicle inventory for the most common OEM parts required to service your equipment. In some cases, due to the sensitivity of components in the (heat or cold) environment of a vehicle, or the rare failure rate of a component, certain parts are not carried. When a technician does not have the part in inventory, they will order from their mobile device for an expedited delivery and arrange a follow up repair visit to coincide with the part arrival.

*Some wearable items are considered consumable, they can be ordered through our supplies web site, but they will not be included in the Standard or Performance SLA. The remote support agent and/or the field service technician can consult with you on managing supplies.

5. **PREVENTIVE MAINTENANCE.** With SLA coverage, you are entitled to up to two (2) preventative maintenance service calls per calendar year. Any preventative maintenance service calls beyond two (2) per calendar year are billed at the rate in effect at the time the preventative maintenance is delivered. PBI determines whether preventative maintenance is performed on-site or remotely. PBI will notify you when preventative maintenance is due or you can request preventative maintenance service by contacting our remote support teams. Note: Our on-site service technicians customarily inspect select hardware products during every service visit to ensure you have trouble free operation and minimal downtime. They will replace any worn parts during every service visit and provide an update of work performed as preventative maintenance.

Additional Benefits of the Performance SLA

The Performance SLA includes every feature of the Standard SLA with the addition of the guaranteed response time and one additional benefit.

1. **TWO-HOUR APPLICATION CONSULTATION.** One two-hour application consultation for your mailing and shipping needs is included with the solution order. Please contact your Sales Representative for more details and scheduling this session.

Software Maintenance Agreements

Pitney Bowes offers a world-class level of technical support to our clients, providing assistance in the resolution of technical issues with Pitney Bowes software products, ensuring that our clients have access to the most up to date versions available of their licensed software, and updates to data subscriptions.

Clients can contact support through the same methods outlined for Standard and Performance SLAs.

Software Maintenance Agreements (SMA) do not include professional services, custom development, new feature additions, hardware support, hardware parts or consumable supplies, equipment support, system back-ups, training, or other services, which, if purchased by you, will be set forth elsewhere in your license agreement or in a separate agreement with PB.

Two (2) levels of Software Maintenance Services ("SMA" or "Maintenance Services") are available to clients, based on the client's needs and elected at time of purchase. SMA Tier 1 is a basic offering and SMA Tier 2 offers an additional benefit of limited onsite support. A Premier Support Add-On Supplement option is available for purchase for on-premise software coverage options SMA Tier 1 and SMA Tier 2, plus also available for most on-demand solution. Additional detail is outlined below.

SMA Tier 1 Overview

As part of SMA Tier 1 Maintenance Services, PB will provide you with the following:

1. **SELF HELP.** 24/7 access to web self-help and user and product support articles.
2. **TECHNICAL SUPPORT.** PB provides all technical support over the phone and via the Internet ("Remote Support") unless otherwise specified. To receive Remote Support you will be requested to provide access to your system or computer, and it is within your discretion to determine the level of access granted to PB to receive Remote Support, which you grant at your own risk. When logging an issue, it is required that you provide information in sufficient detail for PB to reproduce the problem. PB can also assist you in the diagnosis of your IT environmental or infrastructure issues for an additional fee.
3. **FIXES.** Corrections or changes to the Product to correct errors or otherwise make the Product materially conform to the applicable Product documentation (commonly referred to as "fixes" or "patches").
4. **PRODUCT UPDATES.** PB will provide you with customer-installable updates, some that may be required to support industry compliance or continued use of the Products, as they become commercially available ("Updates"). Updates may include fixes or minor changes to the Product or additional carrier functionality or routine revisions to comply with carrier requirements. Updates may include changes to the Product documentation to reflect changes included in the applicable Update. You must be fully current with the installation of all Updates to be eligible to receive Maintenance Services. New features or functionality for the Product and non-routine or non-generally applicable revisions ("Upgrades") may become available from time to time, for an additional fee. PB reserves the right not to add functionality or carrier services, even though they may be available from the carrier.
5. **DATA UPDATES.** If your Product includes data that is licensed separately as a subscription ("Data"), PB will distribute to you each Update to the Data as they are made available to PB by its third-party vendors, or with the frequency set forth in your license agreement or Order. If you require additional distribution of the Data or a Data Update, an additional service charge may apply.

SMA Tier 1 Overview (continued)

6. **RATE CHANGES.** If your Product requires carrier rate information supplied by PB, client-installable rate change replacements **will be provided** to you based on the carrier coverage selected in the Order. Rate change replacements include postal or carrier rate increases and decreases, zip code or zone changes and changes in service provided by carriers (e.g. required new report formats or geographical expansions) and, if elected on the Order, a single UPS custom rate change per calendar year. Rate changes do not include other custom rate changes, new classes of services offered by carriers, and new rates needed to establish a new home zip code because of a change in location.
7. **DELIVERY; IMPLEMENTATION.** All Updates, Upgrades, fixes, Data Updates and rate changes will be delivered electronically unless physical media options are provided at PB's discretion. All Updates, etc. are your responsibility to install and implement unless otherwise agreed to in writing by PB, which will incur fees at PB's then current rates.
8. **ON-SITE SUPPORT.** On-site support is **not** offered under SMA TIER 1 maintenance service. If you request on-site support, you will incur fees at PB's then-current rates at the time of the request.

SMA Tier 2 Overview (Available in US only)

SMA Tier 2 includes all the services provided in **SMA Tier 1**, and if the Remote Support team is unsuccessful at resolving the reported issue, on-site service and support will be provided at your location for no additional charge. If PB determines that support must be provided on-site, such support will be provided Monday through Friday, from 8 am to 5pm in your local time zone, excluding PB observed holidays. Average response time is within one (1) business day of PB determining that on-site support is required. Request for on-site support outside of these hours or without providing PB with access and opportunity to solve issues remotely may result in additional fees.

Premier Support Clients

Upon initial sign up for Premier Support, your assigned Account Manager will contact you at the phone number you provide with your Order, confirm future preferred method of contact, and discuss the following benefits.

You will be given a premier 4-digit PIN number to access the team of Premier Support Agents and Case Managers. This gives you direct access to Level 2 Support Desk Agents and Case Managers for product support issues.

When you use the premier PIN code, your call will be queued in front of all non-Premier calls and routed to the Level 2 Support Desk Agents. As a result, your call will be answered ahead of any other non-Premier callers.

To learn more detail on service contract offerings for most hardware, please visit the web link below.

What is covered under each Service Level Agreement option for hardware?

<https://www.pitneybowes.com/us/support/billing/what-is-covered-under-each-service-level-agreement-option.html>

To learn more detail on service contract offerings for software, please visit the web links below.

What is covered under our Software Maintenance Agreements for software?

<https://www.pitneybowes.com/us/license-terms-of-use/shipping-and-mailing-maintenance-services-terms.html>

Software Maintenance Agreements Cut Sheet

<https://www.pitneybowes.com/content/dam/pitneybowes/us/en/business-services/maintenance-support/pdf/17-ent-06244-pbgs-software-maintenance-agreement-cut-sheet-us-web.pdf>

Escalation Management

Pitney Bowes has a well-defined escalation process across the organization. The first point of escalation for a client should be a request to the call center agent handling their case. All call center agents are training to handle escalations in a timely and acceptable manner. If there is still no satisfactory outcome, the call will be referred to a call center manager. The call center management team is there to ensure escalations are addressed in an organized and transparent manner. Call center managers work closely with both the client and relevant departments to ensure issues and success criteria are clearly understood and that communications are clear and predictable. All parties are kept up to date with a clearly defined action plan to achieve success. In the most extreme cases, a call may be referred to the Office of the President, to ensure executive oversight through satisfactory resolution of the issue.

An outline of the coverage attributes associated to our service offerings is listed below.

A – Available at an additional charge * = at Pitney Bowes discretion	Hardware Products		Software Products		
	Standard SLA	Performance SLA	SMA Tier 1	SMA Tier 2	SMA Premier Support
Self Help: 24/7 access to web self-help and product support articles.	✓	✓	✓	✓	✓
Technical Support: Telephone and Remote, Mon – Fri 8AM – 8PM EST excluding holidays.	✓	✓	✓	✓	✓
On-Site Support*: Mon-Fri 8AM – 5PM Local time, excluding holidays.	✓	✓	A	✓	✓
Phone Support First In Line Routing					✓
24/7 Emergency Standby Phone Support Coverage	A	A	A	A	A
Next Business Day Onsite Support*	✓				
Guaranteed Response Onsite Support*		✓			
Expedited Overnight Parts Shipment	A	A	A	A	A
Parts and Labor	✓	✓			
Preventive Maintenance	✓	✓			
One 2 Hour Application Consultation	A	✓			
Assigned Account Support Manager					✓
Direct Access to Premier Support Technicians					✓
Prep for Move and Post Move Re-Install	A	A	A	A	A
Refresher Training	A	A	A	A	A

Follow Us



CODE: 510-0400 ARPA Expenditures

SECTION 56-6

Bid2024-107 Purchase Dugout Benches for City Park

Global Industrial
11 Harbor Park Dr.
Port Washington, NY 11050

Contract Award: \$3,242.50

Contract Period: One Time Purchase



JUN 29 2023

CITY OF WARWICK
DEPARTMENT OF PUBLIC WORKS
925 SANDY LANE • WARWICK, RHODE ISLAND 02889
TEL (401) 738-2003 • FAX (401) 732-5208

FRANK J. POGGIA
MAYOR

ERIC J. EARLS, PE
DIRECTOR OF PUBLIC WORKS

To: Francis Gomez, Purchasing Agent

From: Eric J. Earls, PE, Public Works Director *EJE*

Date: June 28, 2023

Subj: Dugout Benches for City Park

A request has been made to replace the benches at the City Park dog park and the four ball fields that are used for softball with ARPA funds in Ward 6. In an effort to maximize the purchasing needs for this project, the four benches currently in the ball field dugouts will be moved to the dog park, therefore, only the benches for the dugout will be purchased. This vendor has the proper length and installation setup required for the size and construction of the City Park dugouts.

These projects are on the approved City Council Resolution R-117-22 for APRA improvements.

This is a one-time project and therefore no contract period is necessary. As we are in the beginning of a long softball season, this department is requesting a Sec. 56-6, Exception to Notice from Global Industrial. It should also be noted that because of the aluminum material these benches are made from, it is likely that the price may rise if the purchase is delayed. The total cost for the (8) dugout benches is \$3,242.50, including shipping. These benches will be installed by City personnel.

(510-0400 - \$3,242.50 – Ward 6)



11 HARBOR PARK DRIVE
PORT WASHINGTON, NY 11050

Sales Quote

Account #: 2117608	Quote #: 7034099	Quote Issued: 06/28/2023
City of Warwick, RI	christy.l.moretti@warwickri.gov	*Pricing valid for 30 days from quote issue date. subject to change based on product availability and/or extraordinary market conditions
Christy Moretti	Phone: (401) 921-9602	
3275 POST RD	Fax:	
WARWICK, Rhode Island 02886		
<u>CLICK HERE TO LOGIN AND PLACE THIS ORDER ONLINE.</u>		

Part#	Description	Shipping	Quantity	Price	Extended
B2310978	15' Aluminum Team Bench, Backless, Surface Mount Country Of Origin: UNITED STATES	TRUCK	8	\$325.95	\$2,607.60
Item Total:					\$2,607.60
Shipping and Handling:					\$634.90
PLEASE BE SURE TO REVIEW OUR TERMS AND CONDITIONS					*Total: \$3,242.50

Notes	Thank you for the opportunity to help with your needs. To place your order or for further assistance please contact me. Name: AUDREY CAMP Email: ACamp@globalindustrial.com Phone: (470) 655-3580 x123580 Fax:
--------------	--

*Applicable taxes and shipping charges will be added to invoice.



11 Harbor Park Drive, Port Washington, N.Y. 11050
Copyright © 2023 by Global Industrial. All Rights Reserved.

Help | Contact Us

This order is subject to Global Industrial's Terms & Conditions of Sale. Global Industrial objects to any other additional or different terms in your purchase order or acceptance.

CODE: 30-330 Police Department – Auto & Vehicle Maintenance

SECTION 6-12

Request permission to increase PCR-118-22 (Sub A) from \$5,000.00 to \$8,000.00

Bid2023-190 Police Automotive Graphics Replacement

MHQ
401 Elm St.
Marlboro, MA 01752

Global Public Safety
60 Alhambra Rd.
Suite #6
Warwick, RI 02886

LAST ACTION TAKEN

Award (Sec. 6-12): PCR-145-22 (Sub A) approved on December 22, 2022 to add MHQ as an additional vendor.

Contract Increase Requested:	\$3,000.00
Current Contract Award:	\$5,000.00
Contract Period Requested	No Change in Contract Period
Current Contract Period	10/21/2022 – 10/20/2023

CITY OF WARWICK

Bradford E. Connor
Chief of Police

Frank J. Picozzi
Mayor



JUN 29 2023

Police Department
99 Veterans Memorial Drive
Warwick, Rhode Island 02886-4617
Telephone: (401) 468-4200

June 28, 2023

Ms. Francis Gomez, Purchasing Agent
City of Warwick
3275 Post Road
Warwick, Rhode Island 02886

Re: 6-12 Alteration to bid
Police Automotive Graphics Replacement
Bid# 2023-190
Funding source: Auto/vehicle maintenance 30-330

Dear Ms. Gomez:

The Police Department previously went out to bid for police vehicle graphics replacement for marked police vehicles.

Of the three bids received, Global Public Safety of Warwick was initially awarded the one-year bid and subsequently MHQ of Marlboro, MA was added in December of 2022 in a previous 6-12 Alteration to Contract on this bid due to supply chain issues.

The Police Department is requesting an increase in spending authority in the amount of \$3,000. This would bring the new bid total to \$8,000. The requested increase in spending authority is due to unforeseen bid expenses. These expenses are partially attributed to the upfitting of equipment the police department received at no cost such as two all-terrain vehicles and trailers.

If the increase is approved, this bid will continue to be funded by police operating budget code 30-330 "Auto/vehicle maintenance." Purchases will continue to be made on an as-needed basis.

The bid contract term of 10/21/22-10/20/23 will remain unchanged.

Please feel free to contact me if you have any questions or concerns.

Sincerely

A handwritten signature in black ink, appearing to read "Andrew P Sullivan".

Andrew P Sullivan
Administrative Bureau Commander

CITY OF WARWICK
 STATE OF RHODE ISLAND
 RESOLUTION OF THE CITY COUNCIL

MEETING DATE: 12/19/2022

NO: R-22-124

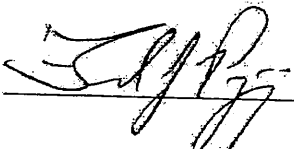
APPROVED:  MAYOR

DATE: 12-22-22

RESOLVED, That The City Council of the City of Warwick as required by the provisions of Sections 6-11 and 6-12 of the City Charter and the Ordinance relative to competitive bidding on purchase enacted there under hereby and herewith approves the acceptance of the following bid(s):

Bid #	Name	Vendor(s) Name/Address	Contract Award	Contract Period	Note	Code
2023 - 300	State of RI Vehicle Repairs	Ballard Mack Sales & Serv of RI Inc. Diesel Maintenance Services LLC Fleet Master Inc. Paul Masse Chevrolet Inc. Rhode Island Diesel Equipment Service LLC Smithfield Diesel & Transmission Repair Inc. Strobes & More Tasca Automotive Group Inc.	\$300,000.00 Inclusive of Bid 2023-300 & 2023-301	Date of award - 6/30/25	1	56 - 10

Continued next page

Bid #	Name	Vendor(s) Name/Address	Contract Award	Contract Period	Note	Code
2023 - 301	State of RI Automotive and Truck Repairs Heavy Trucks	<i>Advantage Truck Raynam LLC</i> <i>AT Northern Warwick LLC d/b/a Coastal International</i> <i>Ballard Mack Sales & Serv of RI Inc.</i> <i>Diesel Maintenance Services LLC</i> <i>Fleet Master Inc.</i> <i>Rhode Island Diesel Equipment Service LLC</i> <i>Rhode Island Truck Center LLC</i> <i>Smithfield Diesel & Transmission Repair Inc.</i> <i>Strobes & More</i> <i>Tasca Automotive Group Inc.</i>	Inclusive of Bid 2023-300 & 2023-301	Date of award - 6/30/25	2	56 - 10
2023 - 251	Purchase 2023 or Newer Chevrolet 3500 HD	<i>Liberty Chevrolet, Inc.</i> 90 Bay State Road Wakefield, MA 01880	\$203,244.00			
2023 - 245	Copier Equipment, Service, & Maintenance	<i>Artec Office</i> 984 Charles Street N. Providence, RI 02904 <i>Imagetex</i> 11 Powder Hill Road Lincoln, RI 02865 <i>Axion/Visual Edge IT</i> 80 Cypress St. Warwick, RI 02888	\$125,000.00	1/1/23 - 12/31/25		

Continued next page

Bid #	Name	Vendor(s) Name/Address	Contract Award	Contract Period	Note	Code
2023 - 304	Purchase Ford F-150 Responder Vehicles	<i>McGovern Municipal Headquarters</i> 1200 Worcester Road Framingham, MA 01702 <i>Colonial Municipal Group</i> 61 Camelot Dr. Plymouth, MA 02360	\$120,184.80			56 - 6
2023 - 162	Purchase 2023 Chevrolet 3500 HD w/ Plow Package & Dump Body or Equivalent	<i>Liberty Chevrolet, Inc.</i> 90 Bay State Road Wakefield, MA 01880	\$82,729.00		3	6 - 12
2023 - 289	IMC Software Support	<i>Tritech Software Systems, a Central Square Co</i> 1000 Business Center Drive Lake Mary, FL 32746	\$58,435.93	1/1/23 - 12/31/23		56 - 6
2023 - 302	Chevrolet Silverado 2500HD 4WD Double Cab	<i>Colonial Municipal Group CMG</i> 61 Camelot Drive Plymouth, MA 02360	\$51,773.63			56 - 6
2023 - 310	State of RI Software and Services for Database Programming	<i>Accelare</i> <i>CBTS LLC</i> <i>Dell Marketing LP</i> <i>Deloitte Consulting LLP</i> <i>Insight Public Sector, Inc.</i> <i>IntraSystems, Inc.</i> <i>Markley Boston LLC</i> <i>Stonewall Solutions Inc.</i> <i>Zones LLC</i>	\$30,000.00	1/1/23 - 12/31/23	4	56 - 10

Continued next page

PCR-145-22 (Sub A)

Bid #	Name	Vendor(s) Name/Address	Contract Award	Contract Period	Note	Code
2023 - 239	Emergency Equipment Repair for Police Vehicles	<i>Global Public Safety</i> 60 Alhambra Rd. Suite #6 Warwick, RI 02886 <i>All Mobile Towing & Recovery LLC</i> P.O Box 14544 East Providence, RI 02914	\$10,000.00	2/10/23 - 2/9/24		
2023 - 190	Automotive Graphics Replacement	<i>MHO</i> 401 Elm St. Marlboro, MA 01752 <i>Global Public Safety</i> 60 Alhambra Road Suite 6 Warwick, RI 02886	Additional Vendor		5	6 - 12
2023 - 308	State of RI Automated External Defibrillators & AED Equipment	<i>Stryker Sales Corporation</i> 2825 Airview Blvd. Portage, MI 49002	\$28,908.75		6	56 - 10
2023 - 309	Entry-Level Firefighter Written Examination	<i>IPMA-HR</i> 1617 Duke St. Alexandria, VA 22314	\$4,620.00			56 - 6
2023 - 299	Remove & Replace Hanging Systems	<i>D. Larsen & Son</i> 2 Huckleberry Ct. Warwick, RI 02888	\$23,940.00			56 - 6
2023 - 298	Reinstall Unit at McDermott Pool	<i>D. Larsen & Son</i> 2 Huckleberry Ct. Warwick, RI 02888	\$17,415.00			56 - 6

Continued next page

Bid #	Name	Vendor(s) Name/Address	Contract Award	Contract Period	Note	Code
2023 - 297	Install Indoor & Outdoor Camera System	<i>Electronic Alarms</i> 10 Jefferson Blvd. Warwick, RI 02888	\$15,901.48			56 - 6
2023 - 311	Municipal Court Software & Support	<i>Curia Systems, Inc.</i> PO Box 2031 East Greenwich, RI 02818	\$10,000.00	9/1/22 - 8/31/23		56 - 6
2023 - 316	Repairs to W16	<i>Affordable Auto Body</i> 96 Evergreen Ave. Warwick, RI 02888	\$13,627.77			56 - 6

AND BE IT FURTHER RESOLVED, That such purchase or contract be awarded to the lowest responsible bidder.

1. Request permission to piggyback State MPA#203A
2. Request permission to piggyback State MPA#203B
3. Request permission to increase PCR-114-22 (Sub A) from \$248,187.00 to \$330,916.00.
4. Request permission to piggyback State MPA#227
5. Request permission to award PCR-118-22 (Sub A) to MHQ as an additional vendor.
6. Request permission to piggyback State MPA#370

Actions Taken:

2023-288 Food and Paper Products

**PCR-147-22
Held 01/04/2023**

THIS RESOLUTION SHALL TAKE EFFECT UPON ITS PASSAGE

Additional Vendor

SECTION 6-12

Request permission to award PCR-118-22 (Sub A) to MHQ as an additional vendor.

Bid2023-190 Police Automotive Graphics Replacement

MHQ
401 Elm St.
Marlboro, MA 01752

Global Public Safety
60 Alhambra Road Suite 6
Warwick, RI 02886

LAST ACTION TAKEN

Award (Bid) PCR-118-22 (Sub A) approved October 18, 2022 in the amount of \$5,000.00. Contract Period October 21, 2022 through October 20, 2023.

Contract Increase Requested: No monies requested
Current Contract Award: \$5,000.00

Contract Period Requested: No change in term
Current Contract Period: October 21, 2022 ~~2024~~ October 20, 2023

CITY OF WARWICK

DEC 05 2022

Bradford E. Connor
Chief of Police

Frank J. Picozzi
Mayor



COPY

Police Department
99 Veterans Memorial Drive
Warwick, Rhode Island 02886-4617
Telephone: (401) 468-4200

December 5, 2022

Ms. Francis Gomez, Purchasing Agent
City of Warwick
3275 Post Road
Warwick, Rhode Island 02886

Bid2023-190 Police Automotive Graphics Replacement
6-12 Alteration to Contract
Funding source: Auto/vehicle maintenance 30-330

Dear Ms. Gomez:

The Police Department previously went out to bid for police vehicle graphics replacement for marked police vehicles.

We received three (3) bids for bid # 2023-190, Police Automotive Graphics Replacement. The bids were received from the following three companies:

Global Public Safety of 60 Alhambra Road Suite 6 Warwick, RI 02886
MHQ of 401 Elm Street Marlboro, MA 01752
Municipal Graphics Inc. of 30 Commercial Drive Wrentham, MA 02093

The Police Department recommended **Global Public Safety** be awarded this contract as they were the lowest qualified bidder. This recommendation was subsequently approved. Since the bid began on October 21, 2022, there have been supply delays that are affecting timely repairs and upfitting of our police vehicles. Although Global Public Safety has a local address, the orders are fulfilled out-of-state which is partially the cause of the delays. The police department is recommending the contract bid be altered to now include **MHQ** of Marlboro, MA as a second vendor within the bid contract. **MHQ**, the 2nd overall lowest qualified bidder, has previously demonstrated timely service and supplies in other service contracts and dealings.

If approved, it will continue to be funded by police operating budget code 30-330 "Auto/vehicle maintenance" for an amount not to exceed \$5,000 and will still expire on the original expiration date of October 20, 2023. Purchases will continue to be made on an as-needed basis.

Please feel free to contact me if you have any questions or concerns.

Sincerely

Andrew P Sullivan
Administrative Bureau Commander

CITY OF WARWICK

STATE OF RHODE ISLAND

RESOLUTION OF THE CITY COUNCIL

MEETING DATE: 10/17/2022

NO: R-22-99

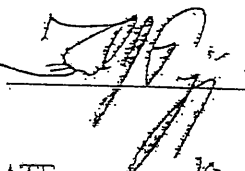
APPROVED:  _____ MAYOR
 DATE: 10-18-22

RESOLVED, That The City Council of the City of Warwick as required by the provisions of Sections 6-11 and 6-12 of the City Charter and the Ordinance relative to competitive bidding on purchase enacted there under hereby and herewith approves the acceptance of the following bid(s):

Bid #	Name	Vendor(s) Name/Address	Contract Award	Contract Period	Note	Code
2023 - 164	Shoreline Adaptation Inventory and Design Project, Strand Avenue & Seaview Drive, Warwick, RI	Cardi Corporation 400 Lincoln Ave. Warwick, RI 02888	\$654,000.00	One year from date of award		
2023 - 219	Purchase Ford Excavator Police Interceptor	McGovern Municipal Headquarters 1200 Worcester Road Frammingham, MA 01702	\$311,276.10	One year from date of award		55 - 6
2023 - 087	Remove and Replace or Repair Roofs at DPW Complex	Commercial Roofing & Contracting, Inc. 340 Kennedy Drive Putnam, CT 06260	\$286,000.00			

Continued next page

Bid #	Name	Vendor(s) Name/Address	Contract Award	Contract Period	Note	Code
2023 - 223	Purchase Trackless MT7	<i>CY Wood</i> 200 Merrimac Street Woburn, MA 01801	\$756,200.00			56 5
2023 - 168A	Purchase Various New Tires	<i>Sullivan Tire Co, Inc.</i> 1199 Jefferson Blvd. Warwick, RI 02886	\$100,000.00 DPW	1/1/23 - 12/31/23		
2023 - 180A	Police Personnel Uniforms	<i>Barney's Uniform</i> 922 Cranston Street Cranston, RI 02920	\$50,000.00	12/12/22 - 12/11/23		
2023 - 180B	Police Personnel Uniforms	<i>Various Vendors</i>	\$8,000.00	12/12/22 - 12/11/23		56 - 6
2023 - 168B	Purchase Various New Tires	<i>Sullivan Tire Co, Inc.</i> 1199 Jefferson Blvd. Warwick, RI 02886	\$30,000.00 POLICE	1/1/23 - 12/31/23		
2023 - 185	Emergency Lighting Equipment	<i>Strobes N More</i> 81 Tom Harvey Rd. Westley, RI 02891	\$10,000.00	1/4/23 - 1/3/24		
2023 - 190	Police Automotive Graphics Replacement	<i>Global Public Safety</i> 60 Alhambra Rd Ste. 6 Warwick, RI 02886	\$5,000.00	One year from date of award		
2023 - 171	Testing & Repair of Self Contained Breathing Apparatus	<i>MES - Shipman's Fire Equipment Co.</i> 172 Cross Road Waterford, CT 06385	\$45,000.00	12/16/22 - 12/15/24		
2022 - 254	Firefighting Vessel Maintenance Services	<i>Webster Marine</i> 47 Goodling Ave. Bristol, RI 02809	\$10,000.00		1	6 - 12
2023 - 179	Photography Equipment	<i>W.B Hunt Co., Inc.</i> 100 Main Street Melrose, MA 02176	\$8,000.00	One year from date of award		

Continued next page

COPY

PCR-118-22 (Sub A)

Bid #	Name	Vendor(s) Name/Address	Contract Award	Contract Period	Note	Code
2023 - 225	Purchase 2001 E-One 1500 GPM Pumper	<i>Town of Rehoboth</i> 340 Anawan Street Rehoboth, MA 02769	\$3,500.00			56 - 6
2023 - 154	Work Boots	<i>Saf-Gard Shoe Co.</i> 2701 Patterson St. Greensboro, NC 27407	\$21,420.00	11/21/22 - 11/20/25		
2021 - 277	Portable Toilet Rentals	<i>Scituate Portable Restroom, Inc.</i> 26 Greenhill Rd. Johnston, RI 02919	\$15,000.00		2	6 - 12
2023 - 181	Landscape Architectural Services Playground & Related Site Improvements at Bishop Park	<i>BETA Group, Inc.</i> 701 George Washington Highway Lincoln, RI 02865	\$40,000.00	One year from date of award		
2018 - 251	Consulting Services Buckeye Brook Permitting-Remedial Action	<i>EA Engineering, Science & Technology, Inc.</i> 301 Metro Center Bldg. Ste. 102 Warwick, RI 02886	\$24,033.00		3	6 - 12
2023 - 209	Construction Administration for SAID Project Straad Avenue & Seaview Drive	<i>GZA Geo Environmental, Inc.</i> 188 Valley Street, Suite 300 Providence, RI 02909	\$6,000.00	One year from date of award		56 - 6
2023 - 155	Liquid Chlorine for McDermott Pool	<i>Roberts Chemical Co., Inc.</i> 330B Victor Road Attleboro, MA 02703	\$20,000.00	1/1/23 - 12/31/24		

Continued next page

Bid #	Name	Vendor(s) Name/Address	Contract Award	Contract Period	Note	Code
		<i>Safety-Kleen Systems, Inc.</i>				
2022 - 162	Motor Oil, Hydraulic & Transmission Fluids, Chassis Grease & Gear Lube	42 Longwater Drive, Norwell, MA 02061 <i>Dennison Lubricants</i> 111 Rhode Island Road Lakeville, MA 02347 <i>Raps Auto Supply (NAPA)</i> 3666 West Shore Road Warwick, RI 02886	\$15,000.00		4	6 - 12
2023 - 222	Precast Items for Manholes & Catch Basins	<i>Old Castle APG Northeast Inc. (Anchor Concrete)</i> 30 Budlong Road Cranston, RI 02920	\$14,000.00	One year from date of award		56 - 6
2023 - 221	Repairs to H115	<i>Milton CAT</i> 100 Quarry Drive Milford, MA 01757	\$10,314.18			56 - 6
2023 - 159	Rodent Control Materials	<i>SiteOne Landscape</i> 1385 East 36 th Street Cleveland, OH 44114	\$10,000.00	12/5/22 - 12/4/23		
2023 - 156	Quick Pro Dry or Equal	<i>Winfield Solutions LLC dba Winfield United</i> 4001 Lexington Avenue N Alden Hills, MN 55126	\$5,000.00	12/23/22 - 12/23/23		

AND BE IT FURTHER RESOLVED, That such purchase or contract be awarded to the lowest responsible bidder.

1. Request permission to increase PCR-159-21 (amended) from \$10,000.00 to \$20,000.00.

COPY

2. Request permission to Increase PCR-46-21 (Sub A) from \$25,000.00 to \$40,000.00
3. Request permission to Increase PCR-62-22 (Sub A) from \$213,108.00 to \$237,141.00
4. Request permission to Increase PCR-137-21 (Sub A) from \$45,000.00 to \$60,000.00

Actions Taken:

2023-220 Body Worn Camera's Software & Associated Equipment PCR-119-22 (Sub A)
Amend total award
from \$953,750.00 to
\$910,000.00

2023-224 Post Collision Vehicle Inspection Training PCR-120-22 (Sub A)
Amend total award
from \$2,695.16 to
\$2,545.16

2021-226 Turnkey Operation for Printing & Mailing of Water,
Sewer, & Tax Billing PCR-121-22
Favorable Action

2023-231 Roofing Materials for 196 Range Road PCR-122-22
Favorable Action

THIS RESOLUTION SHALL TAKE EFFECT UPON ITS PASSAGE

Bid2023-190 Police Automotive Graphics Replacement

COPY

- 3 Bids Received

CODE: 30-330 Police Dept./ Auto & Vehicle Maintenance

MANNER OF AWARD: \$5,000.00
One year from date of award

RECOMMEND: Global Public Safety

Municipal Graphics Inc.
30 Commercial Drive
Wrentham, MA 02093

MHQ
401 Elm St.
Marlboro, MA 01752

Global Public Safety
60 Alhambra Road Suite 6
Warwick, RI 02886

Pricing as follows

Bid2023-190 Police Automotive Graphics Replacement

COPY

RESULTS

Item	Description	Municipal Graphics	MHQ	Global Public Safety
1	WPD Patch Logo 3m Reflective			
A	4 inch	\$8.00	\$11.00	\$5.80
B	6 inch	\$16.00	\$15.00	\$7.20
C	8 inch	\$24.00	\$22.00	\$9.80
D	12 inch	\$32.00	\$29.00	\$13.00
2	WPD Patch with American & RI State Flag Logo in 3M Reflective			
A	4 inch	\$8.00	\$11.00	\$6.80
B	6 inch	\$16.00	\$15.00	\$7.65
C	8 inch	\$24.00	\$22.00	\$10.00
D	12 inch	\$32.00	\$29.00	\$13.60
3	WPD Unit Numbering			
A	2 inch windshield	\$10.00	\$5.00	\$2.00
B	4 inch side & rear	\$20.00	\$12.00	\$4.00
4	Complete Vehicle Graphics Kit for 2020 Ford Utility Police Cruiser w/ Hash Marks			
A	Installed	\$995.00	\$895.00	\$838.00
B	Material Only	\$895.00	\$695.00	\$538.00
5	WPD Patch "Non Reflective" Material			
A	1 inch patch logo	\$4.00	\$2.00	\$0.75
B	2 inch patch logo	\$6.00	\$3.00	\$1.20
C	4 inch patch logo	\$8.00	\$4.00	\$3.40
6	WPD Patch with American Flag & RI State Flag "Non Reflective Material"			
A	2 inch Patch/Flag combo	\$10.00	\$3.00	\$2.20
B	4 inch patch/flag combo	\$26.00	\$4.00	\$4.05
7	Driver's Side door High Reflective Kit			
A	Lime Green	\$75.00	\$50.00	\$54.00

COPY

Police - Carruolo Gina

From: Police - Grant Michael
Sent: Monday, August 29, 2022 11:56 AM
To: Police - Carruolo Gina
Cc: 'Paul Johnson'
Subject: VENDOR LIST GRAPHICS

GREG GORMAN greg@signlogics.com
Bill Camillucci bcamillucci@mcgovernauto.com
Briana St. Germain bstgermain@mha.com
bor11985@aol.com
joe@nksigns.com
jodi municipalgraphics.com jodi@municipalpublicsafety.com
Paul.johnson@Globalpublicsafety.us

Michael J. Grant

Michael J. Grant
Fleet Manager
Warwick Police Dept.
401-468-4362 Office
401-639-9309 Cell

CITY OF WARWICK

SEP 30 2022

Bradford E. Connor
Chief of Police

Frank J. Picozzi
Mayor



COPY

Police Department
99 Veterans Memorial Drive
Warwick, Rhode Island 02886-4617
Telephone: (401) 468-4200

September 29, 2022

Mrs. Patricia Peshka, Purchasing Agent
City of Warwick
3275 Post Road
Warwick, Rhode Island 02886

Re: Bid Recommendation: Police Automotive Graphics Replacement
Bid# 2023-190
Funding source: Auto/vehicle maintenance 30-330

Dear Mrs. Peshka:

The Police Department went out to bid for police vehicle graphics replacement for marked police vehicles.

We received three (3) bids for bid # 2023-190, Police Automotive Graphics Replacement. The bids were received by the following three companies:

Global Public Safety of 60 Alhambra Road Suite 6 Warwick, RI 02886
MHQ of 401 Elm Street Marlboro, MA 01752
Municipal Graphics Inc. of 30 Commercial Drive Wrentham, MA 02093

The Police Department recommends **Global Public Safety** be awarded this contract as they were the lowest qualified bidder. There is not a contract currently in place for Police Automotive Graphics Replacement. If approved, it will be funded by police operating budget code 30-330 "Auto/vehicle maintenance" for an amount not to exceed \$5,000 and will expire one year from the date of award. Purchases will be made on an as needed basis.

Please feel free to contact me if you have any questions or concerns.

Sincerely

A handwritten signature in black ink, appearing to read "Andrew P. Sullivan".

Andrew P Sullivan
Administrative Bureau Commander

CODE: 68-956 Recycling – Sale of Scrap Metal
68-958 Recycling – Sale of Compost/Wood Chips
68-959 Recycling – Sale of Textiles
68-999 Recycling – Misc. Department Credits

SECTION 56-6

Bid2024-099 Municipal Recycling Facility By Products

Various Vendors

Contract Award: Revenue

Contract Period: July 1, 2023 – June 30, 2024



CITY OF WARWICK
DEPARTMENT OF PUBLIC WORKS
925 SANDY LANE • WARWICK, RHODE ISLAND 02889
TEL (401) 738-2003 • FAX (401) 732-5208

JUN 26 2023

FRANK J. PICOZZI
MAYOR

ERIC J. EARLS, PE
DIRECTOR OF PUBLIC WORKS

To: Francis Gomez, Purchasing Agent

From: Eric J. Earls, Director of Public Works *EJE*

Date: June 22, 2023

Subj: Municipal Recycling Facility By-Products

Yearly, by Council award, the Public Works Department has been disposing of the above products (metal, compost, wood chips etc.) by selling it at the highest market value to various vendors on the date it is delivered to the vendor facility. The process is supervised by the Public Works Director in cooperation with the Purchasing Agent to assure the City is receiving the highest possible price. This system has proven effective and we are requesting permission to continue with this program in fiscal year 2024.

Please consider this memo a request for an exception to notice under Sec. 56-6 of the Warwick Code for various vendors on an as needed basis. This is a revenue generated request. The current exception expires June 30, 2023. The new exception period will be July 1, 2023 through June 30, 2024.

(68-956, 68-958, 68-959, 68-999 – revenue)