

SITE IMPROVEMENT PLANS

FOR A PROPOSED MULTI-FAMILY DEVELOPMENT CONSISTING OF 4 DWELLING UNITS

GREENWICH BAY TOWNHOUSES

**5 WILLIAMS STREET
WARWICK, RHODE ISLAND
AP 220, LOT 95**

ZONING DISTRICT: RESIDENCE A-10 DISTRICT (A-10) with (PDR-L) PLANNED RESIDENTIAL-LIMITED OVERLAY



IMAGE COURTESY OF STUDIO 401 ARCHITECTURE, LLC

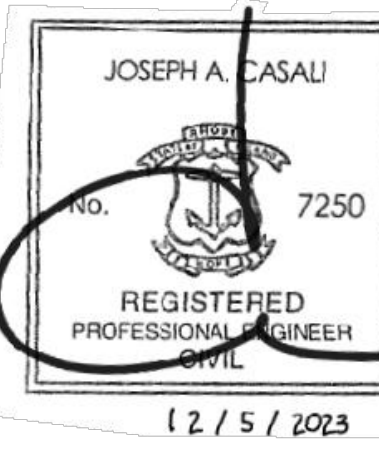
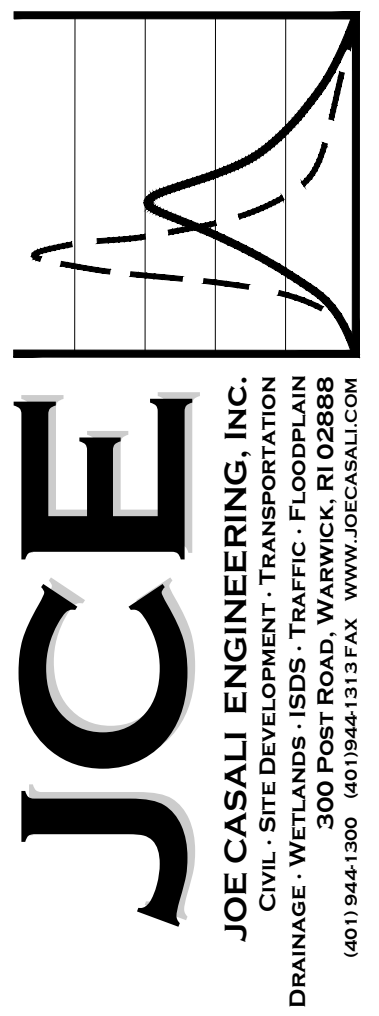

STIPULATIONS PER THE FEBRUARY 8, 2023 MASTER PLAN APPROVAL

- THAT WORK IMMEDIATELY ADJACENT TO THE TRAIN TRACK MAY REQUIRE REVIEW AND AUTHORIZATION FROM THE CONSOLIDATED RAIL CORPORATION.
- THAT, SANITATION SERVICES SHALL BE PRIVATE AND ALL COST(S) SHALL BE BORNE BY THE PROPERTY OWNERS. THE CITY OF WARWICK WILL NOT PROVIDE TRASH AND RECYCLING SERVICES.

APPROVALS:

WARWICK PLANNING BOARD OF REVIEW - MASTER PLAN APPROVAL WITH A CITY COUNCIL ZONE CHANGE RECOMMENDATION (FEBRUARY 8, 2023)
 WARWICK CITY COUNCIL - PETITION GRANTED FOR A ZONE CHANGE OF THE SUBJECT PARCEL TO RESIDENCE A-10 DISTRICT (A-10) WITH THE PLANNED DISTRICT RESIDENTIAL-LIMITED (PDR-L) OVERLAY (APRIL 17, 2023)
 RHODE ISLAND COASTAL RESOURCE MANAGEMENT COUNCIL (CRMC) - CATEGORY 'A' COUNCIL ASSENT NO. A2023-07-069 (OCTOBER 12, 2023)

FILINGS:

- WARWICK PLANNING BOARD OF REVIEW - PRELIMINARY PLAN
- KENT COUNTY WATER AUTHORITY
- WARWICK SEWER AUTHORITY
- WARWICK DEPARTMENT OF PUBLIC WORKS, ENGINEERING DIVISION

GREENWICH BAY TOWNHOUSES
 5 WILLIAMS STREET
 WARWICK, RHODE ISLAND
 AP 220, LOT 95

C:\20-10 Steven Miller\20-10b-Williams Street\CAD\Williams St, Warwick, [Preliminary Plan] - R1.dwg Dec. 07, 2023 9:41am

PROJECT TEAM			
OWNER/ APPLICANT:	JMR PROPERTIES, INC. C/O MR. STEPHEN MILLER 40 MALBONE STREET WARWICK, RI 02888 PHONE: 401-641-4455	CIVIL ENGINEER:	JOE CASALI ENGINEERING, INC. 300 POST ROAD WARWICK, RI 02888 PHONE: 401-944-1300 FAX: 401-944-1313
ARCHITECT:	STUDIO 401 ARCHITECTURE, LLC 5 DIVISION STREET, UNIT 39 WARWICK, RI 02818 PHONE: 401-884-1546	SURVEYOR:	OCEAN STATE PLANNERS, INC. 1225 OAKLAWN AVENUE CRANSTON, RI 02920 PHONE: 401-463-9696
	LANDSCAPE ARCHITECT:		DIANE C. SOULE & ASSOCIATES, ASLA 422 FARNUM PIKE SMITHFIELD, RI 02917 PHONE: 401-231-0736

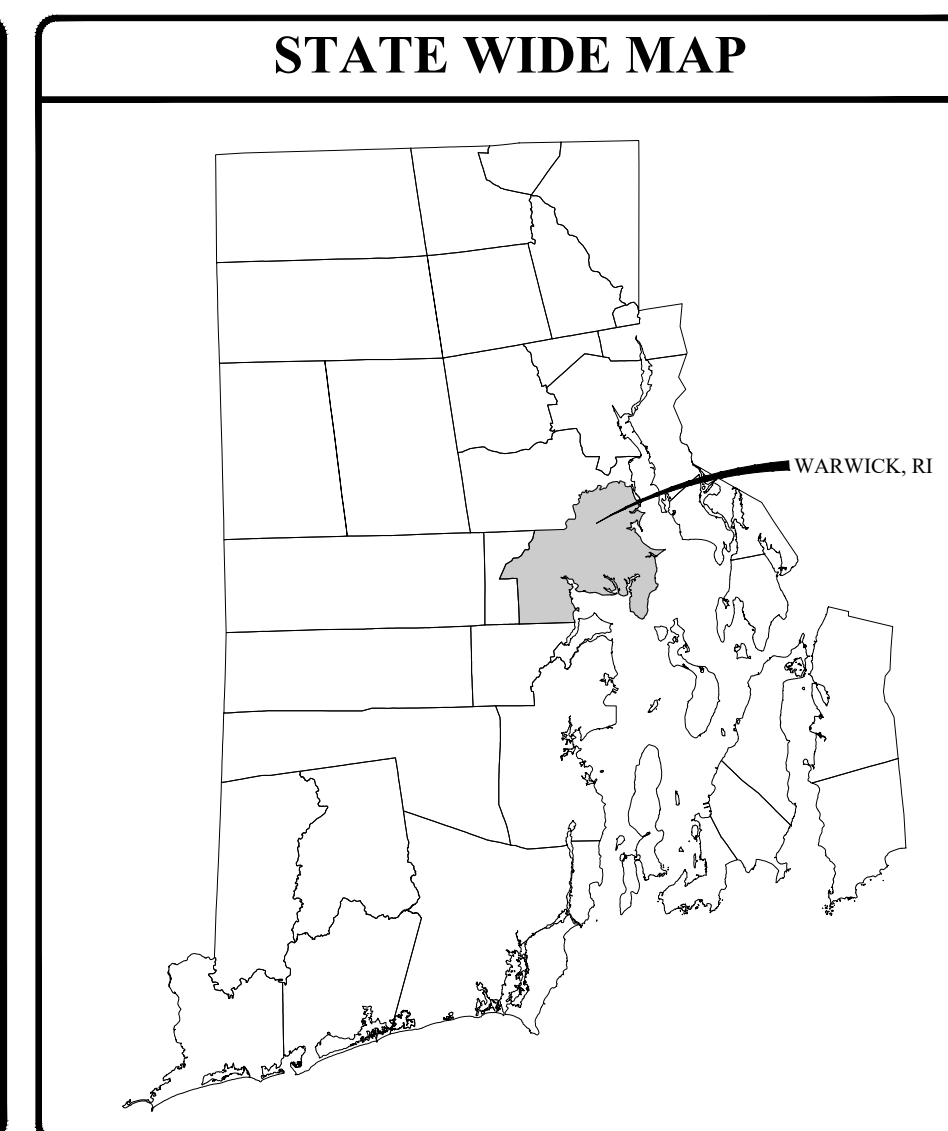
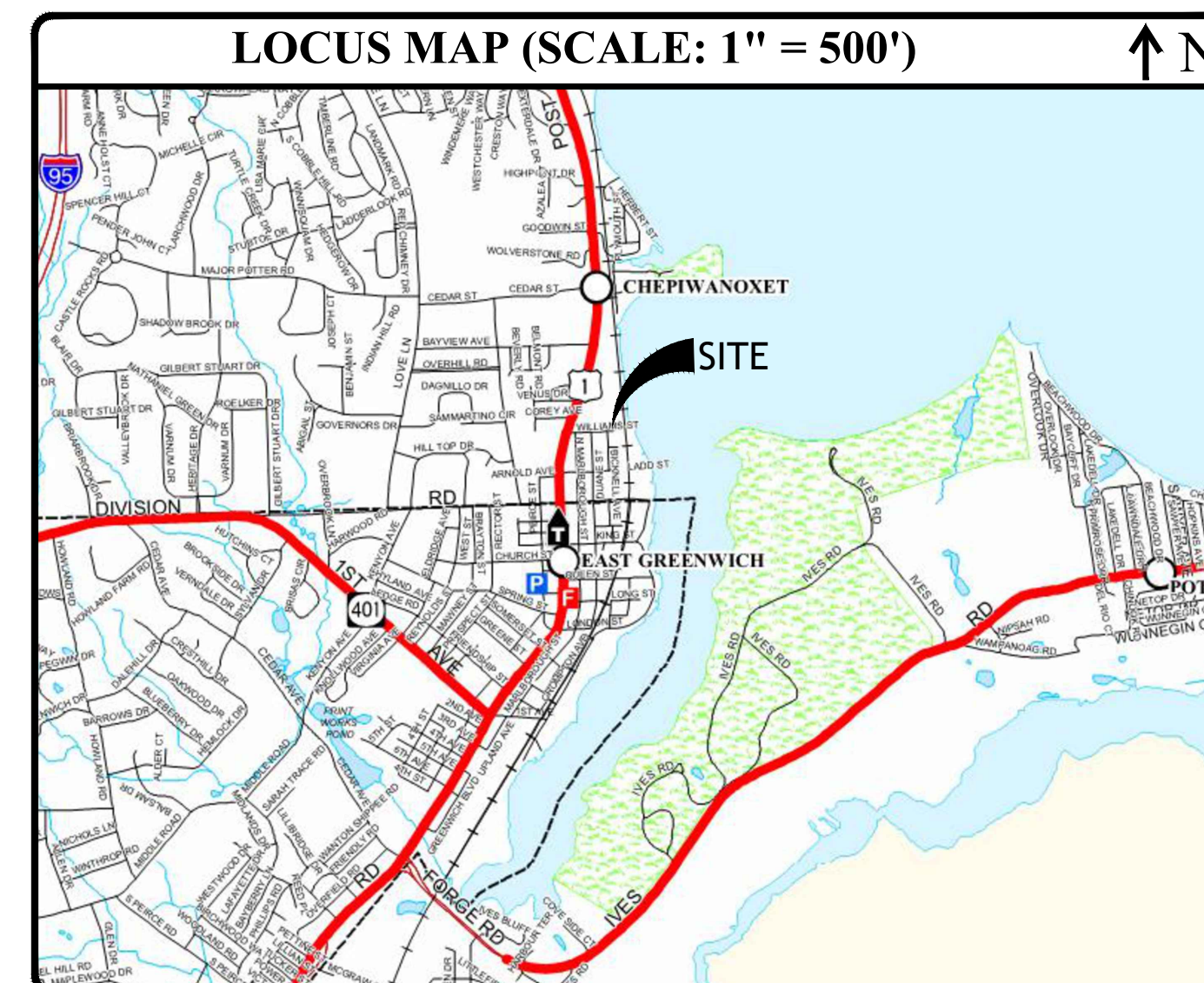

INDEX OF DRAWINGS	
SHEET NO.	PLAN
1	COVER SHEET
2	GENERAL NOTES AND LEGEND
3	EXISTING CONDITIONS & SITE PREPARATION PLAN
4	SITE PLAN
5	GRADING & DRAINAGE PLAN
6	UTILITY PLAN
7	DETAILS I
8	DETAILS II
9	KCWA NOTES
R1	BOUNDARY STAKE-OUT SURVEY, PREPARED BY OCEAN STATE PLANNERS, DATED NOVEMBER 2023
R2	LANDSCAPE PLAN, PREPARED BY DIANE C. SOULE AND ASSOCIATES, DATED JULY 2023

REVISIONS:		
NO.	DATE	DESCRIPTION
R1	1/9/22	REV SETBACKS
R2	7/2023	PERMIT SET
R3	12/2023	CITY COMMENTS

DESIGNED BY:	WMLJR
DRAWN BY:	SEP
CHECKED BY:	JAC
DATE:	20-10b
PROJECT NO.:	NOV. 2022

PRELIMINARY, NOT FOR CONSTRUCTION

COVER SHEET

SHEET 1 OF 9

GENERAL NOTES:

- CLASS I PROPERTY LINE & CLASS III TOPOGRAPHIC SURVEY COMPLETED BY OCEAN STATE PLANNERS, INC. OF 1255 OAKLAWN AVENUE, CRANSTON, RI 02920 IN FEBRUARY 2022.
- THE SITE LIES WITHIN FLOOD ZONE X (AREAS DETERMINED TO BE OUTSIDE THE 0.2% ANNUAL CHANCE FLOODPLAIN) AS SHOWN ON THE FIRM MAP FOR THE CITY OF WARWICK, MAP NUMBER 44003C0137H, EFFECTIVE DATE SEPTEMBER 18, 2013.
- THE SUBJECT PARCEL IS NOT LOCATED WITHIN A HISTORIC DISTRICT. THERE ARE NO EXISTING STRUCTURES LOCATED ON THE SUBJECT PARCELS LISTED ON THE NATIONAL HISTORIC REGISTER. THERE ARE NO HISTORIC CEMETERIES OR STONE WALLS ON OR IMMEDIATELY ADJACENT TO THE PROPOSED DEVELOPMENT.
- THERE ARE NO EASEMENTS WITHIN THE SUBJECT PARCEL.
- A PORTION OF THE SITE LIES WITHIN THE 200-FOOT CRMC JURISDICTIONAL BUFFER ASSOCIATED WITH GREENWICH COVE.
- EXISTING SOILS ON THE SITE HAVE BEEN CLASSIFIED AS HINCKLEY LOAMY SAND, 8-15 SLOPES (HKC). HKC SOILS ARE CLASSIFIED AS HYDROLOGIC GROUP A AND ARE CONSIDERED FARMLAND OF STATEWIDE IMPORTANCE.
- THE SUBJECT PARCEL IS NOT LOCATED WITHIN A NATURAL HERITAGE AREA OR A GROUNDWATER PROTECTION AREA.
- PUBLIC WATER, SEWER AND GAS ARE AVAILABLE TO THE PROJECT SITE.

SITE NOTES:

- CONTRACTOR SHALL BE RESPONSIBLE FOR REMOVING AND LEGALLY DISPOSING (R&D) OF ALL MATERIALS INDICATED ON THE PLANS.
- ACCESSIBLE ROUTES, PARKING SPACES, RAMPS, SIDEWALKS, AND WALKWAYS SHALL BE CONSTRUCTED IN CONFORMANCE WITH THE FEDERAL AMERICAN WITH DISABILITIES ACT AND WITH ALL APPLICABLE STATE AND LOCAL LAWS AND REGULATIONS, WHICHEVER IS MORE STRINGENT.
- STOCKPILES OF EARTH MATERIALS SHALL NOT BE LOCATED ADJACENT TO DRAINAGE STRUCTURES.
- ALL DISTURBED AREAS OUTSIDE OF THE PAVED AREAS WILL RECEIVE A MINIMUM OF 6" OF LOAM AND SEED.
- THE LAYOUT SHOWN REPRESENTS A GRAPHICAL DESIGN, AND PRIOR TO THE CONSTRUCTION, THE CONTRACTOR SHALL ENGAGE A PROFESSIONAL LAND SURVEYOR (PLS) REGISTERED IN THE STATE OF RHODE ISLAND TO SET AND VERIFY ALL LINES AND GRADES. ALL EXISTING UTILITY LOCATIONS AND ELEVATIONS ARE TO BE CONFIRMED BY THE CONTRACTOR PRIOR TO CONSTRUCTION. ANY ITEMS FOUND WHICH DO NOT MATCH THE PLANS MUST BE BROUGHT TO THE ENGINEERS ATTENTION PRIOR TO CONSTRUCTION FOR REVIEW. NO WORK SHALL PROCEED UNTIL AUTHORIZED BY THE ENGINEER.
- THE CONTRACTOR SHALL PROVIDE AND MAINTAIN SURVEY LAYOUT SERVICES FOR THE WORK AND SHALL SUBMIT "AS-BUILT" DRAWINGS OF ALL WORK, WHICH SHALL BE STAMPED AND CERTIFIED BY A RHODE ISLAND REGISTERED PROFESSIONAL LAND SURVEYOR.
- ANY ITEM OF WORK NOT SPECIFICALLY INDICATED ON THE PLANS BUT IS REQUIRED FOR THE COMPLETE CONSTRUCTION OF THE PROJECT WILL BE CONSIDERED INCIDENTAL TO THE CONTRACT AND INCLUDED IN THE CONTRACT BID PRICE. IT WILL BE THE CONTRACTOR'S RESPONSIBILITY TO VERIFY ALL EXISTING SITE CONDITIONS.
- REFER TO ARCHITECTURAL PLANS, STRUCTURAL PLANS, PLUMBING PLANS AND ELECTRICAL PLANS FOR ACTUAL SIZE OF THE PROPOSED BUILDINGS AND WORK WITHIN 5 FEET OF THE PROPOSED BUILDINGS.
- WHERE NECESSARY TO REMOVE CURBS, CATCH BASINS OR DRAINS TO COMPLETE WORK, THE CONTRACTOR SHALL REPLACE SUCH ITEMS TO THE SATISFACTION OF THE OWNER AT NO ADDITIONAL COST TO THE OWNER.
- ANY EXISTING PIPE OR UTILITY DAMAGED BY THE CONTRACTOR'S OPERATIONS SHALL BE REPAIRED IMMEDIATELY BY THE CONTRACTOR AT NO COST TO THE OWNER.
- THE CONTRACTOR SHALL RESTORE TO ITS ORIGINAL CONDITION OR REPLACE TREES, SHRUBS, FENCES, SIGNS, GUARDRAILS, DRIVEWAYS, SIDEWALKS AND ANY OTHER OBJECT AFFECTED BY THIS OPERATION, UNLESS OTHERWISE NOTED ON THE SITE PLANS.
- THE TOPS OF ALL VALVE BOXES AND CURB BOXES SHALL BE FLUSH WITH GROUND OR PAVEMENT SURFACE LEVEL AND PLUMB, UNLESS OTHERWISE DIRECTED.
- ROADWAYS SHALL BE LEFT PASSABLE AT ALL TIMES. CLOSURE OF ROADWAY IS NOT PERMITTED.
- WATER SERVICE SHALL BE MAINTAINED AT ALL TIMES.
- IF ENCOUNTERED, ALL LEDGE TO BE REMOVED BY MECHANICAL MEANS.
- ALL CONSTRUCTION WORK SHALL BE PERFORMED IN THE DRY. THE CONTRACTOR SHALL PROVIDE, OPERATE AND MAINTAIN ALL PUMPS, DRAINS, WET POINTS, SCREENS, OR OTHER FACILITIES NECESSARY TO CONTROL, COLLECT AND DISPOSE OF ALL SURFACE AND SUBSURFACE WATER ENCOUNTERED IN THE PERFORMANCE OF THE WORK.
- ALL SITE WORK, INCLUDING BUT NOT LIMITED TO, BITUMINOUS PAVEMENT, ROADWAY CONSTRUCTION, AGGREGATE MATERIALS, DRAINAGE STRUCTURES, CURBING, SIDEWALK, LANDSCAPING, SAW CUTTING, ETC. SHALL CONFORM TO THE RHODE ISLAND DEPARTMENT OF TRANSPORTATION STANDARD SPECIFICATIONS FOR ROADWAY AND BRIDGE CONSTRUCTION, AMENDED DECEMBER 2010 (WITH LATEST ADDENDA) AND THE RIDOT STANDARD DETAILS, 1998 EDITION (WITH LATEST ADDENDA).

MAINTENANCE AND PROTECTION OF TRAFFIC NOTES:

- THE CONTRACTOR SHALL BE RESPONSIBLE FOR ALL MAINTENANCE AND PROTECTION OF PEDESTRIAN AND VEHICULAR TRAFFIC INCLUDING POLICE PROTECTION. ALL TEMPORARY AND VEHICULAR SIGNS, BARRICADES AND LANE CLOSURES SHALL BE IN CONFORMANCE WITH THE LATEST REVISIONS OF THE MANUAL OF UNIFORM TRAFFIC CONTROL DEVICES (MUTCD), 2009 EDITION.
- TEMPORARY CONSTRUCTION SIGNS AND ALL APPLICABLE TRAFFIC CONTROL DEVICES SHALL BE IN PLACE PRIOR TO THE START OF WORK IN ANY AREA OPEN TO TRAFFIC.
- THE PRIVATE VEHICLES OF CONSTRUCTION WORKERS SHALL NOT BE PARKED IN THE CITY RIGHT-OF-WAY.
- ALL MAINTENANCE AND PROTECTION OF TRAFFIC CONTROL SETUPS, SIGNS CHANNELING DEVICES, ETC. SHALL BE IN ACCORDANCE WITH THE LATEST REVISIONS OF THE MANUAL OF UNIFORM TRAFFIC CONTROL DEVICES, 2009 EDITION.
- SIGN MOUNTINGS SHALL BE IN ACCORDANCE WITH THE RIDOT SPECIFICATIONS FOR TEMPORARY CONSTRUCTION SIGNS.

DRAINAGE SYSTEM NOTES:

- THE PROPOSED DRAINAGE LINES SHALL BE ADS N-12 HDPE PIPE OR AN APPROVED EQUAL UNLESS OTHERWISE NOTED ON THE SITE PLANS.
- ALL RIM ELEVATIONS SHOWN ARE APPROXIMATE AND ARE TO BE SET FLUSH WITH FINAL GRADES.

SOIL EROSION AND SEDIMENTATION CONTROL NOTES

- THE LIMITS OF CLEARING, GRADING, AND DISTURBANCE SHALL BE KEPT TO A MINIMUM WITHIN THE PROPOSED AREA OF CONSTRUCTION. ALL AREAS OUTSIDE OF THESE LIMITS, AS DEPICTED ON THE PLAN SHALL BE TOTALLY UNDISTURBED, TO REMAIN IN NATURAL CONDITION.
- ALL CATCH BASINS SHALL BE PROTECTED WITH SILTSACK SEDIMENT TRAPS DURING CONSTRUCTION ACTIVITIES. ALL PROPOSED STORM WATER DISCHARGE AREAS SHALL BE LINED WITH A RIPRAP SPLASH PAD AND PROTECTED WITH STAKED HAYBALE OUTLET PROTECTION (R.I. STD. 9-1.0), OR STAKED HAYBALE WITH SILT FENCE (R.I. STD. 9-3.0) OUTLET PROTECTION (STAKED HAYBALE OR STAKED HAYBALE WITH SILT FENCE) SHALL ALSO BE INSTALLED AT ALL EXISTING STORMWATER DISCHARGE LOCATIONS WHERE DISTRIBUTING PIPES, CATCH BASINS, AND MANHOLES ARE TO BE CLEANED AND FLUSHED.
- ALL DISTURBED SLOPES EITHER NEWLY CREATED OR CURRENTLY EXPOSED SHALL BE SEEDED, PROTECTED AND MAINTAINED BY THE CONTRACTOR. THE CONTRACTOR SHALL REGULARLY CHECK ALL SEEDED AREAS TO ENSURE THAT A GOOD STANDING OF VEGETATION IS MAINTAINED.
- ALL SILT FENCE, TEMPORARY TREATMENT (HAY, STRAW, ETC.) AND TEMPORARY EROSION PROTECTION SHALL BE MAINTAINED BY THE CONTRACTOR THROUGHOUT CONSTRUCTION AND SHALL REMAIN IN PLACE UNTIL AN ACCEPTABLE STAND OF GRASS OR APPROVED GROUND COVER IS ESTABLISHED.
- STOCKPILES OF TOPSOIL SHALL NOT BE LOCATED NEAR WATERWAYS. THEY SHALL HAVE SIDE SLOPES OF NO GREATER THAN 2:1 AND SHALL BE TEMPORARILY SEEDED AND/OR STABILIZED PER CONTRACT SPECIFICATIONS.
- THE SILT FENCE/HAYBALES SHALL BE CHECKED BY THE CONTRACTOR ON A WEEKLY BASIS AND AFTER EACH STORM FOR UNDERMINING OR DETERIORATION. THE CONTRACTOR SHALL REPAIR OR REPLACE ANY SILT FENCE/HAYBALES AS NEEDED. THE CONTRACTOR SHALL CLEAN THE ACCUMULATED SEDIMENT IF HALF OF THE ORIGINAL HEIGHT OF THE HAY-BALES BECOMES FILLED WITH SEDIMENTS.
- IT SHALL BE THE RESPONSIBILITY OF THE CONTRACTOR TO MAINTAIN ALL SOIL EROSION AND SEDIMENT CONTROLS ON THE PROJECT SITE FOR THE ENTIRE DURATION OF THE CONSTRUCTION PERIOD. THE CONTRACTOR SHALL FOLLOW THE DIRECTION OF THE RESIDENT ENGINEER, TOWN ENGINEER, OR OWNER WITH REGARD TO INSTALLATION, MAINTENANCE, AND REPAIR OF ALL SOIL EROSION AND SEDIMENTATION CONTROLS ON THE PROJECT SITE. TEMPORARY SOIL EROSION AND SEDIMENTATION CONTROLS (HAYBALES, SILT FENCE, ETC.) SHALL BE MAINTAINED UNTIL ALL EXPOSED SOILS ARE SATISFACTORILY STABILIZED. THE CONTRACTOR SHALL BE RESPONSIBLE FOR REPAIRING AND/OR RESEEDING ALL AREAS THAT DO NOT DEVELOP WITHIN ONE YEAR FROM THE COMPLETION OF CONSTRUCTION.
- ALL REFERENCED SOIL EROSION AND SEDIMENTATION CONTROLS INCLUDING MATERIALS USED, APPLICATION RATES AND THE INSTALLATION PROCEDURES SHALL BE PERFORMED PER THE "RHODE ISLAND EROSION AND SEDIMENTATION HANDBOOK", DATED 1993 AMENDED 2014.

MISCELLANEOUS UTILITY NOTES:

- PRIOR TO CONSTRUCTION ALL POTENTIAL UTILITY/DRAINAGE CONFLICTS MUST BE IDENTIFIED BY THE CONTRACTOR. ANY MODIFICATIONS TO THE PROPOSED UTILITIES TO AVOID CONFLICTS MUST BE APPROVED BY THE ENGINEER PRIOR TO CONSTRUCTION.
- OVERHEAD ELECTRIC AND TELEPHONE SERVICES ARE TO BE REMOVED BY THE APPROPRIATE UTILITY COMPANY AND COORDINATED BY THE CONTRACTOR.
- THE CONTRACTOR SHALL AT ALL TIMES PROVIDE A SUFFICIENT NUMBER OF WORKMEN AND GUARDS AS MAY BE NECESSARY TO PROPERLY SAFEGUARD THE PUBLIC FROM THEIR OPERATIONS.
- THE CONTRACTOR SHALL TAKE PRECAUTIONS AGAINST DAMAGING OF PAVING, SIDEWALKS, UTILITIES, OR PRIVATE PROPERTIES AND SHALL PROMPTLY REPAIR AT THEIR OWN EXPENSE ANY DAMAGE TO SUCH PAVING, SIDEWALKS, UTILITIES, OR PRIVATE PROPERTIES TO THE SATISFACTION OF THE OWNER OR CITY.
- EXISTING UTILITY FRAMES AND COVERS FOR SANITARY SEWER, WATER, GAS, STORM DRAINAGE AND OTHER UTILITIES SHALL BE ADJUSTED TO GRADE AS REQUIRED IN NEW PAVING AND PAVEMENT OVERLAY AREAS.
- ALL SEWER CONSTRUCTION SHALL BE PERFORMED IN ACCORDANCE WITH THE WARWICK SEWER AUTHORITY REQUIREMENTS.
- ALL NEW SEWER PIPES AND MANHOLES SHALL BE CLEANED AND TESTED PRIOR TO ACCEPTANCE. GRAVITY SEWER PIPES SHALL BE REQUIRED TO PASS BOTH LOW PRESSURE AIR AND DEFLECTION (IE., MANDREL) TESTING. LOW PRESSURE SEWER PIPING SHALL BE REQUIRED TO PASS A LOW PRESSURE (IE., HYDROSTATIC) TEST.
- A BACKFLOW PREVENTION DEVICE MUST BE INSTALLED AT EACH SEWER SERVICE BUILDING CONNECTION THAT IS BELOW THE RIM ELEVATION OF THE NEAREST SEWER MANHOLE, AS REQUIRED BY THE INTERNATIONAL PLUMBING CODE AND THE WARWICK SEWER AUTHORITY.
- APPLICANT IS REQUIRED TO PROVIDE TWO SETS OF FINAL AS-BUILT PLANS TO WARWICK SEWER AUTHORITY AND ENGINEERING DEPARTMENT UPON COMPLETION OF CONSTRUCTION, PRIOR TO FINAL ACCEPTANCE. AS-BUILT PLANS SHALL INCLUDE FIELD MEASUREMENTS OF ALL INSTALLED PIPE AND APPURTENANCES, INCLUDING LENGTH, SLOPE, MANHOLE RIMS AND INVERTS, AS WELL AS SWING TIES/MEASUREMENTS TO ALL MANHOLES, SEWER STUBS, AND/OR LATERAL SERVICE CONNECTIONS.
- INSPECTION OF ALL SEWER CONSTRUCTION SHALL BE PERFORMED BY WARWICK SEWER AUTHORITY. APPLICANT SHALL PROVIDE SCHEDULE FOR CONSTRUCTION AS SOON AS POSSIBLE TO ALLOW FOR DEVELOPMENT OF INSPECTION FEE, TO BE PAID BY APPLICANT DIRECTLY TO THE WARWICK SEWER AUTHORITY. UPON PAYMENT OF FEE, COMMENCEMENT OF CONSTRUCTION INSPECTION REQUIRES MINIMUM NOTIFICATION OF 48-HOURS.
- APPLICANT IS RESPONSIBLE FOR SECURING ALL REQUIRED PERMITS FROM LOCAL, STATE, AND/OR FEDERAL AGENCIES WITH REGULATORY JURISDICTION OVER THE PROPOSED WORK. COPIES OF ALL PERMITS SHALL BE PROVIDED TO THE CITY ENGINEER PRIOR TO CONSTRUCTION. ALL SEWER CONSTRUCTION SHALL BE PERFORMED BY A DRAIN LAYER LICENSED IN THE STATE OF RHODE ISLAND AND THE CITY OF WARWICK.
- NO FLOW WILL BE ACCEPTED UNTIL A COMPLETION CERTIFICATE IS ISSUED.
- THE CONTRACTOR SHALL CONFINE HIS CONSTRUCTION OPERATIONS AND ACTIVITIES TO WITHIN THE STREET LINES, EASEMENT AND/OR RIGHT-OF-WAY, AS SHOWN ON THE DRAWINGS.
- PRIOR TO CONSTRUCTION OF THE RELOCATION OF ALL WATER MAINS, THE CONTRACTOR SHALL COORDINATE WITH PROVIDENCE WATER SUPPLY BOARD FOR INSPECTION AND CHLORINATION OF NEW PIPING, FITTINGS AND VALVES.

BMP MAINTENANCE SCHEDULE:

- ALL MAINTENANCE (INCLUDING CLEANING) REQUIRED DURING THE CONSTRUCTION PHASE OF THE PROJECT SHALL BE THE RESPONSIBILITY OF THE CONTRACTOR AND SHALL INCLUDE:
 - MEASURES NEEDED TO ENSURE THE PROPER OPERATION OF THE STORMWATER RUNOFF (DRAINAGE) AND WATER QUALITY CONTROL SYSTEMS TO INCLUDE INSPECTION, CLEANING AND REPAIRS ALL PIPES, INTAKE AND DISCHARGE STRUCTURES, CATCH BASIN SUMPS, AND MANHOLES.
 - INSPECTION OF ALL SLOPES, BERMS, AND OTHER CONTROL STRUCTURES FOR STRUCTURAL INTEGRITY/STABILITY AND EVIDENCE OF SOIL EROSION PROCESSES, AND MAINTENANCE OF THESE STRUCTURES IF NECESSARY. INSPECTIONS SHALL BE PERFORMED FOLLOWING ALL RAIN EVENTS OF 1/2 INCH RAINFALL OR MORE IN A 24-HOUR PERIOD, OR BI-MONTHLY IF NO RAINFALL EVENT OCCURS.
- UPON COMPLETION OF THE PROJECT CONSTRUCTION, AND PRIOR TO VACATING THE SITE, THE CONTRACTOR SHALL CONDUCT A FINAL INSPECTION AND CLEANING OF THE DRAINAGE SYSTEM AND ALL ASSOCIATED STRUCTURES.
- ALL INSTALLATION, CLEANING, AND MAINTENANCE OF THE STORMWATER DRAINAGE SYSTEM SHALL FOLLOW AT LEAST THE RHODE ISLAND DEPARTMENT OF TRANSPORTATION MINIMUM STANDARDS, SECTION 212 AND SECTION 708. WHERE APPROPRIATE, PROCEDURES REGARDING THE DRAINAGE INSTALLATION, CLEANING, INSPECTION, AND MAINTENANCE OF THE STORMWATER DRAINAGE SYSTEM SHALL BE FOLLOWED AS OUTLINED IN THE "RHODE ISLAND STORMWATER DESIGN AND INSTALLATION STANDARDS MANUAL" (RIDEM/RICRAW, 2010).
- AFTER CONSTRUCTION, STORMWATER BMPs SHALL BE INSPECTED AND MAINTAINED BY THE CONDOMINIUM ASSOCIATION AS FOLLOWS:

ROOF DRAIN LEADERS

- PERFORM ROUTINE ROOF INSPECTIONS QUARTERLY.
- KEEP ROOFS CLEAN AND FREE OF DEBRIS.
- KEEP ROOF DRAINAGE SYSTEMS CLEAR.

UNDERGROUND INFILTRATION SYSTEM

- INFILTRATION SYSTEMS SHALL BE INSPECTED ON A BI-ANNUAL BASIS TO ENSURE PROPER FUNCTIONS. INSPECTION PORTS SHALL BE USED TO VERIFY THAT THE SYSTEMS ARE DRAINING WITHIN 72 HOURS. IF THE SYSTEM FAILS TO DRAIN WITHIN 72-HOURS, THE SYSTEM SHALL BE CLEANED OR REPLACED AS NECESSARY.
- THE INFILTRATION SYSTEM SHALL BE INSPECTED BI-ANNUALLY FOR SEDIMENT ACCUMULATIONS. IF THE SYSTEM HAS ACCUMULATED 3 INCHES OF SEDIMENT, THE SEDIMENT SHALL BE REMOVED BY FLUSHING FROM THE SYSTEM WITH HIGH PRESSURE WATER JETS AND AND VACUUMING THE SEDIMENT AND DEBRIS THROUGH THE ACCESS PORTS. ALL SEDIMENT REMOVED SHALL BE DISPOSED OF IN ACCORDANCE WITH ALL STATE AND FEDERAL REGULATIONS.

BIORETENTION BASIN:

- DURING THE SIX MONTHS IMMEDIATELY AFTER CONSTRUCTION, THE INFILTRATION BASIN SHALL BE INSPECTED AFTER THE FIRST TWO RAINFALL EVENTS OF AT LEAST 1.0 INCH TO ENSURE THE SYSTEM IS FUNCTIONING PROPERLY. THEREAFTER INSPECTIONS SHALL BE CONSTRUCTED ON AN ANNUAL BASIS AND AFTER STORM EVENTS GREATER THAN OR EQUAL TO 2 INCHES.
- SILT AND SEDIMENT SHALL BE REMOVED FROM THE BASIN WHEN THE ACCUMULATION EXCEEDS SIX INCHES, OR WHEN WATER PONDS ON THE SURFACE OF THE INFILTRATION BASIN FOR MORE THAN 48 HOURS.
- SOIL EROSION GULLIES SHALL BE REPAIRED WHEN THEY OCCUR.
- THE OUTLET DEVICES SHALL BE CLEANED/REPAIRED WHEN NECESSARY.
- TRASH AND DEBRIS SHALL BE REMOVED WHEN NECESSARY.
- THE OUTLET CONTROL STRUCTURE SHALL BE INSPECTED ANNUALLY TO ENSURE THAT IT IS FUNCTIONING PROPERLY.

ALL REMOVED SEDIMENT IS TO BE TESTED TO DETERMINE POLLUTANT CONTENT. SEDIMENT IS TO BE PROPERLY DISPOSED OF BASED UPON THE TEST RESULTS AND LOCAL, STATE, AND FEDERAL REGULATIONS.

LOAMING & SEEDING

SEEDING ACTIVITIES SHALL BE PERFORMED IN ACCORDANCE WITH SECTION L.02 SEEDING OF THE RHODE ISLAND DEPARTMENT OF TRANSPORTATION STANDARD SPECIFICATIONS FOR ROADWAY AND BRIDGE CONSTRUCTION, 2010 EDITION (WITH LATEST ADDENDA), AND SHALL ALSO CONFORM TO THE FOLLOWING:

- AFTER ROUGH GRADING IS COMPLETED, ALL DISTURBED AREAS AND AREAS LABELED AS "LOAM AND SEED" ARE TO BE BROUGHT TO AN ELEVATION OF 6" BELOW THE PROPOSED FINISHED GRADE. SCARIFY THE SUBGRADE TO A DEPTH OF 12" WITH THE TEETH OF A BACKHOE OR A POWER RAKE TO RESULT IN AN UNCOMPACTED SUBSOIL. 6" OF GOOD QUALITY TOPSOIL IS TO BE APPLIED AND RAKED TO FINISHED GRADE.
- THE TOPSOIL IS TO BE GOOD QUALITY LOAM, FERTILE AND FREE OF WEEDS, STICKS AND STONES OVER 3/4" IN SIZE AND OTHERWISE COMPLYING WITH SECTION M.18.01 OF THE RHODE ISLAND DEPARTMENT OF TRANSPORTATION STANDARD SPECIFICATIONS FOR ROADWAY AND BRIDGE CONSTRUCTION, 2010 EDITION (WITH LATEST ADDENDA).
- PRIOR TO SEEDING OR SODDING, FERTILIZER WITH 10-10-10 OR EQUIVALENT ANALYSIS. AT LEAST 40% OF THE FERTILIZER NITROGEN SHALL BE IN SLOW RELEASE FORM. INCORPORATE THE FERTILIZER INTO THE TOP 1-2" OF THE PLANTING SOIL. APPLY AT A RATE OF 8 LBS. PER 1000 SQUARE FEET.
- APPLY LIME AT A RATE OF ONE TON PER ACRE AND UNIFORMLY INCORPORATE INTO THE TOP 1-2" OF TOPSOIL.
- SEEDING
AFTER THE SEED BED IS PREPARED, SEED IS TO BE BROADCAST EVENLY OVER THE SURFACE AND WORKED INTO THE TOP 1" OF SOIL. SEED SHALL BE APPROVED URI #2 OR APPROVED EQUAL. APPLY AT A RATE OF 4-5 LBS. PER 1000 SQUARE FEET OR AS OTHERWISE DIRECTED BY THE MANUFACTURER.

URI #2 IMPROVED SEED MIX, % BY WEIGHT:
40% CREEPING RED FESCUE
20% IMPROVED PERENNIAL RYEGRASS
20% IMPROVED KENTUCKY BLUEGRASS
20% KENTUCKY BLUEGRASS

RECOMMENDED SEEDING DATES ARE APRIL 1 TO JUNE 15 AND AUGUST 15 TO OCTOBER 15. AT THE CONTRACTORS DISCRETION, SEED MAY BE APPLIED BY HYDROSEEDING RATHER THAN THE METHOD DESCRIBED ABOVE.

SEQUENCE & STAGING OF PROPOSED CONSTRUCTION ACTIVITIES:

THIS IS A GENERAL SEQUENCE AND STAGING OF CONSTRUCTION ACTIVITIES. A DETAILED SEQUENCE WITH TIME LINES SHALL BE ESTABLISHED BY THE CONTRACTOR IN COORDINATION WITH THE OWNER, ENGINEER AND SITE CONTRACTORS PRIOR TO THE START OF CONSTRUCTION.

- SURVEY AND STAKE THE PROPOSED DRAINAGE BMP'S (UNDERGROUND INFILTRATION CHAMBER SYSTEMS), PARKING LOTS, WATER LINE, SEWER LINE AND LIMIT OF DISTURBANCE.
- PLACE SEDIMENTATION BARRIERS (SILT FENCE) AS SHOWN ON THE PLANS AND AS STAKED OUT IN THE FIELD. IN NO CASE IS THE LIMIT OF WORK TO EXTEND BEYOND THE SEDIMENTATION BARRIERS.
- BEGIN SITE WORK (CLEARING AND GRUBBING, EXCAVATING AND GRADING ETC.)TOPSOIL IS TO STRIPPED AND STOCKPILED WITHIN DISTURBANCE LIMITS. THE STOCKPILES ARE TO BE PROTECTED BY A ROW OF SEDIMENTATION BARRIERS. STOCKPILES TO BE COVERED OR TEMPORARILY SEEDED.
- EXCAVATE AND CONSTRUCT STORMWATER MANAGEMENT AREAS AS SHOWN ON PLAN. DIVERT ALL THE RUNOFF FROM DISTURBED AREAS TO THE PROPOSED STORMWATER STORAGE AREA.
- INSTALL UTILITIES AND DRAINAGE INCLUDING DRAINAGE PIPE. SEED ALL DISTURBED AREAS.
- BEGIN BUILDING CONSTRUCTION.
- BEGIN PAVEMENT AND PROPOSED GRADING.
- FINISH PAVEMENT CONSTRUCTION.
- MAINTAIN SEDIMENT AND EROSIONS CONTROLS WHILE BUILDING ARE CONSTRUCTED.
- FINISH LANDSCAPING AND PERMANENT STABILIZATION.
- INSPECT AND REPAIR ALL DRAINAGE STRUCTURES INCLUDING DISCHARGE POINTS. REMOVE ANY DEBRIS (LEAVES, TREE LIMBS, BOULDERS, ETC.) FROM DRAINAGE INLETS AND OUTLETS. FLUSH ALL SEDIMENTS FROM DRAINAGE PIPES AND APPLY TOPSOIL TO PONDS.
- REMOVE ALL TEMPORARY SOIL EROSION AND SEDIMENTATION CONTROL MEASURES ONCE VEGETATION HAS BEEN ESTABLISHED TO ALL DISTURBED AREAS.

LEGEND

- EXISTING PROPERTY LINE
- - - - - ABUTTING PROPERTY LINE
- - - - - BUILDING SETBACK LINE
- 100 --- EXISTING CONTOUR
- 100 --- PROPOSED CONTOUR
- EXISTING STONE WALL
- EXISTING CURB
- PROPOSED CURB
- EXISTING GUARD RAIL
- EXISTING DRAIN LINE
- PROPOSED DRAIN LINE
- EXISTING DRAINAGE MANHOLE
- PROPOSED DRAINAGE MANHOLE
- EXISTING CATCH BASIN
- PROPOSED CATCH BASIN
- EXISTING UTILITY POLE
- PROPOSED UTILITY POLE
- TEL --- EXISTING TELECOM DUCTBANK
- E --- EXISTING ELECTRIC DUCTBANK
- E --- RELOCATED ELECTRIC DUCTBANK
- GAS --- EXISTING GAS LINE
- GAS --- PROPOSED GAS LINE
- W --- EXISTING WATER LINE
- W --- PROPOSED WATER LINE
- EXISTING WATER SHUT OFF VALVE
- PROPOSED WATER SHUT OFF VALVE
- S --- EXISTING SEWER LINE
- S --- PROPOSED SEWER LINE
- EXISTING SEWER MANHOLE
- PROPOSED SEWER MANHOLE
- N/F --- NOW OR FORMERLY
- TREE LINE
- SILT FENCE / COMPOST SOCK
- LIMIT OF DISTURBANCE
- TEST HOLE

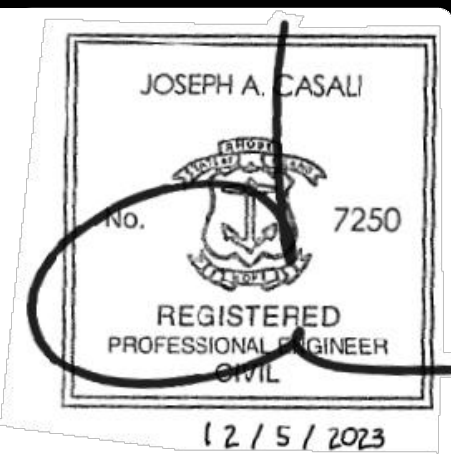
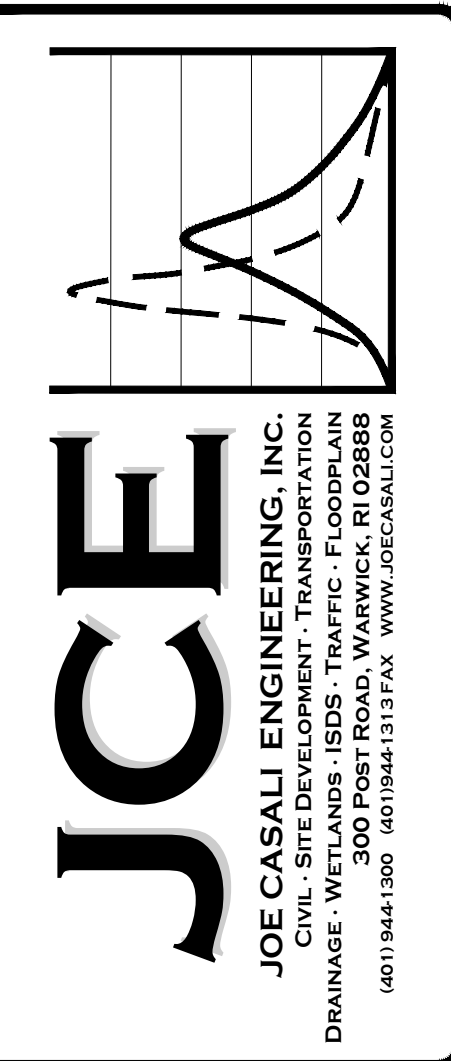

GREENWICH BAY TOWNHOUSES
5 WILLIAMS STREET
WARWICK, RHODE ISLAND
AP 220, LOT 95

NO.	DATE	DESCRIPTION
R1	1/9/22	REV SETBACKS
R2	7/2023	PERMIT SET
R3	12/2023	CITY COMMENTS

DESIGNED BY:	WMLR
DRAWN BY:	SEP
CHECKED BY:	JAC
DATE:	20-10b
PROJECT NO.:	NOV. 2022

PRELIMINARY, NOT FOR CONSTRUCTION

GENERAL NOTES & LEGEND

SHEET 2 OF 9

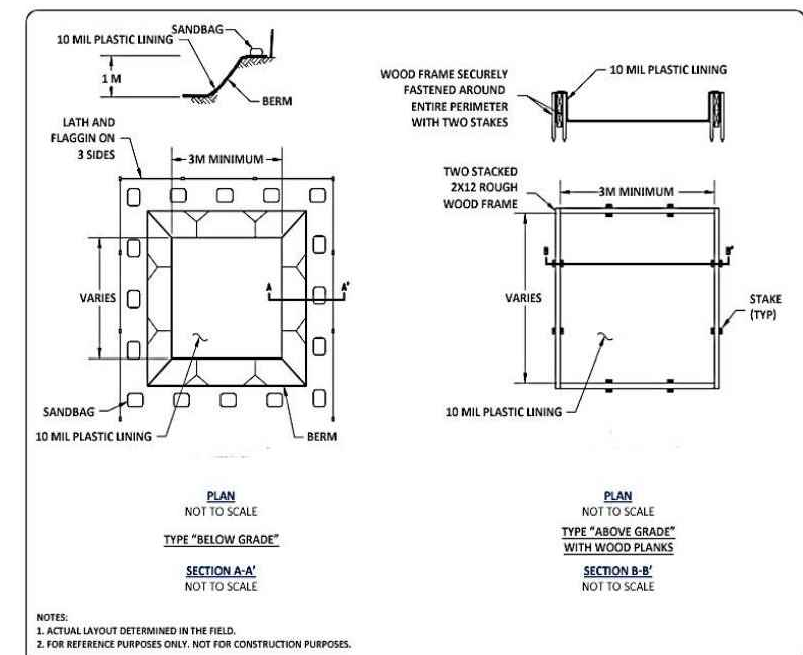

1 TEMP. CONCRETE WASHOUT FACILITY
NOT TO SCALE

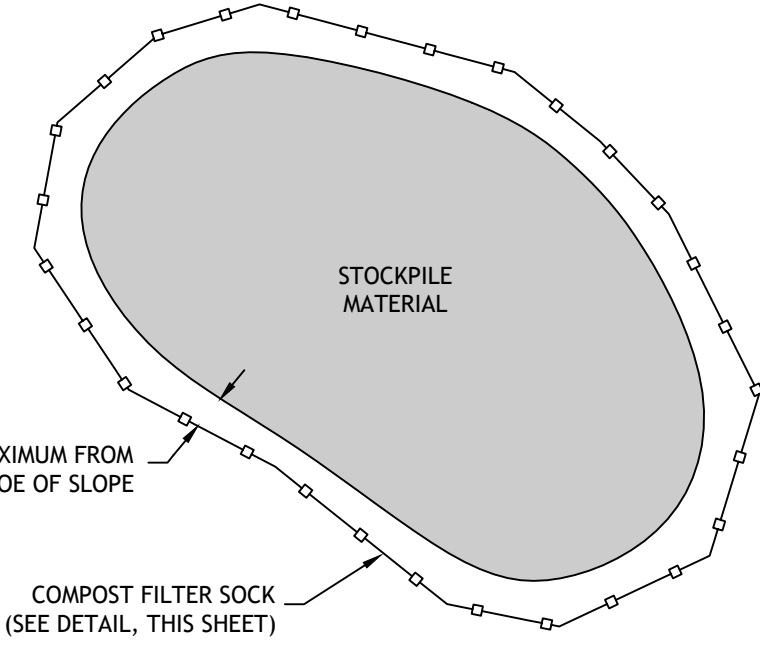

2 STOCKPILE DETAIL
NOT TO SCALE

**ZONING DIMENSIONAL REQUIREMENTS:
PROPOSED MULTI-FAMILY DEVELOPMENT**

ZONING CRITERIA	REQUIRED	EXISTING
ZONING DISTRICT	A-10 (PDR-L)	A-10 (PDR-L)
MULTI-FAMILY (3-9 DWELLING UNITS)		
MINIMUM LOT AREA	30,000 SF	31,529 SF
MAX. DENSITY (D.U. PER AC.)	7	N/A
MINIMUM FRONTAGE	155 FT	100.00 FT ¹
MINIMUM LOT WIDTH	155 FT	237.67 FT
MINIMUM FRONT AND CORNER SIDE YARD	35 FT	N/A
MINIMUM SIDE YARD	25 FT	N/A
MINIMUM REAR YARD	35 FT	N/A
MAXIMUM STRUCTURE HEIGHT	35 FT	N/A
MINIMUM LANDSCAPED OPEN SPACE	25%	N/A

NOTE:
1. PRE-EXISTING, NON-CONFORMING CONDITION

	SOIL EVALUATION TEST PIT DATA	
	SURFACE EL.	SHWT / EL.
TP-1	42.00	>96' / 34.00
TP-2	42.50	>84' / 35.50
TP-3	42.20	>98' / 34.00
TP-4	41.50	>98' / 33.50

NOTE:
TEST PIT EVALUATIONS WERE CONDUCTED BY JOE CASALI ENGINEERING, INC., IN APRIL 2023.

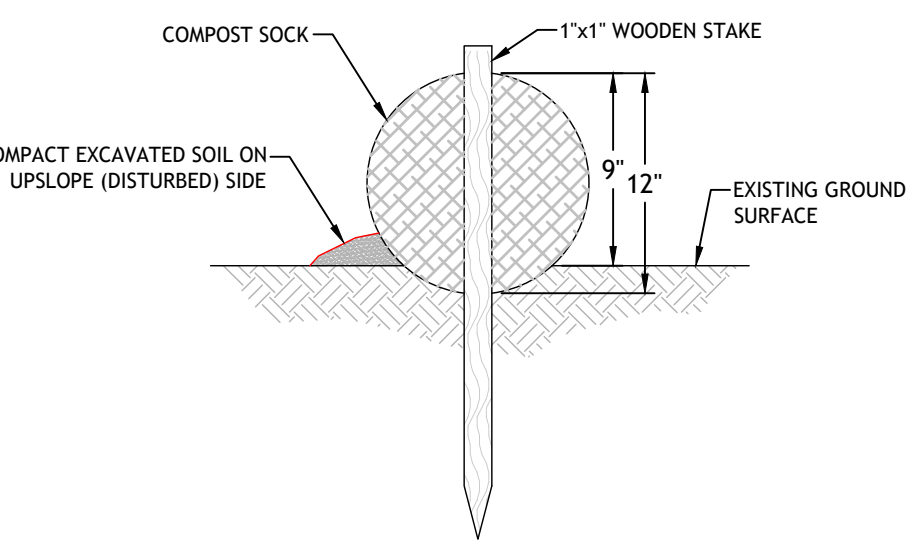

- NOTES:
- BEGIN SOCK INSTALLATION BY EXCAVATING A 2 TO 3-INCH-DEEP BY 9" WIDE TRENCH ALONG THE CONTOUR OF THE SLOPE OR ALONG THE EXISTING GROUND SURFACE. EXCAVATED SOIL SHOULD BE PLACED UP-SLOPE OR ON THE DISTURBED SIDE OF THE ANCHOR TRENCH.
 - PLACE SOCK IN THE TRENCH SUCH THAT IT CONTOURS TO THE EXISTING SOIL SURFACE. COMPACT SOIL FROM THE EXCAVATED TRENCH AGAINST THE SOCK ON THE UP-SLOPE OR DISTURBED SIDE. ADJACENT SOCKS SHOULD TIGHTLY ABUT.
 - SECURE SOCK WITH 18 TO 24-INCH-LONG STAKES. INSTALL AN ADDITIONAL STAKE AT EACH END OF THE SOCK. STAKES SHOULD BE DRIVEN THROUGH THE MIDDLE OF THE SOCK LEAVING AT LEAST 2 TO 3 INCHES OF STAKE EXTENDING ABOVE. THE STAKES SHOULD BE DRIVEN PERPENDICULAR TO THE SLOPE FACE OR GROUND SURFACE.
 - COMPOST FILTER SOCK SPACING BASED ON 12-INCH DIAMETER SOCK; SHOULD SMALLER OR LARGER DIAMETER SOCK BE USED, SPACING SHALL BE ADJUSTED BASED ON TABLE 2 (TO THE RIGHT).
 - COMPOST FILTER SOCK INSTALLATION AND MAINTENANCE SHALL BE IN ACCORDANCE WITH THE RI SOIL EROSION AND SEDIMENT CONTROL HANDBOOK, 2014.
 - COMPOST FILTER SOCKS SHALL BE MAINTAINED UNTIL PERMANENT VEGETATIVE COVER IS ESTABLISHED.

3 COMPOST FILTER SOCK
NOT TO SCALE

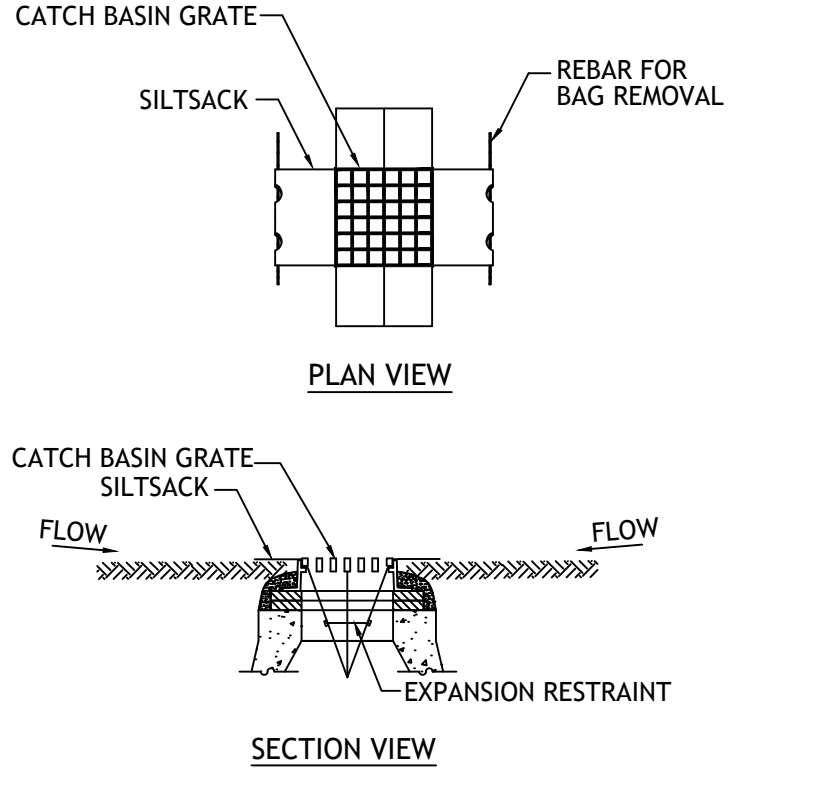

- Notes:
- INSTALL SILTSACK IN ALL PROPOSED CATCH BASINS IDENTIFIED ON THE GRADING & DRAINAGE PLAN.
 - GRATE TO BE PLACED OVER SILTSACK. SILTSACK SHALL BE INSPECTED PERIODICALLY AND AFTER ALL STORM EVENTS AND CLEANING OR REPLACEMENT SHALL BE PERFORMED PROMPTLY AS NEEDED. MAINTAIN UNTIL UPSTREAM AREAS HAVE BEEN PERMANENTLY STABILIZED.

4 SILT SACK SEDIMENT TRAP
NOT TO SCALE

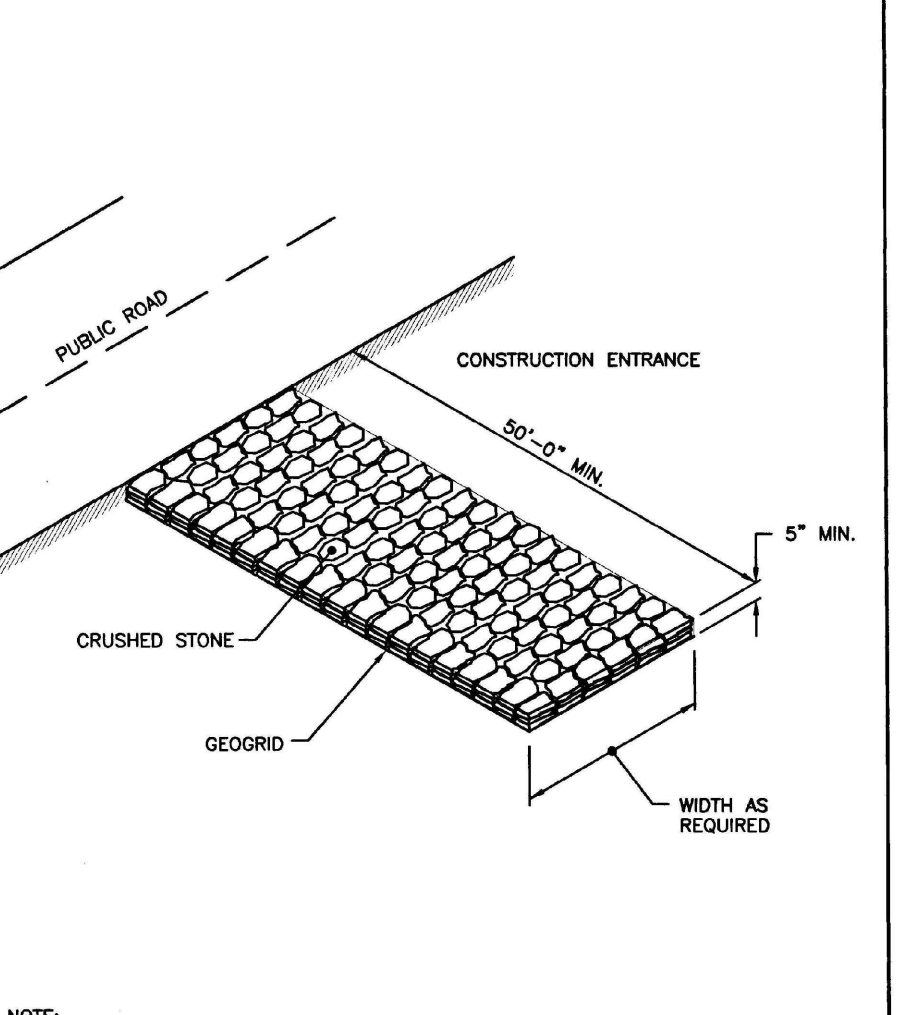

NOTE:
SHALL BE IN ACCORDANCE WITH SECTION 211 OF THE R.I. STANDARD SPECIFICATIONS.

RHODE ISLAND DEPARTMENT OF TRANSPORTATION		
NO.	BY	DATE
CONSTRUCTION ACCESS		
		R.I. STANDARD 9.9.0
JUNE 15, 1998		

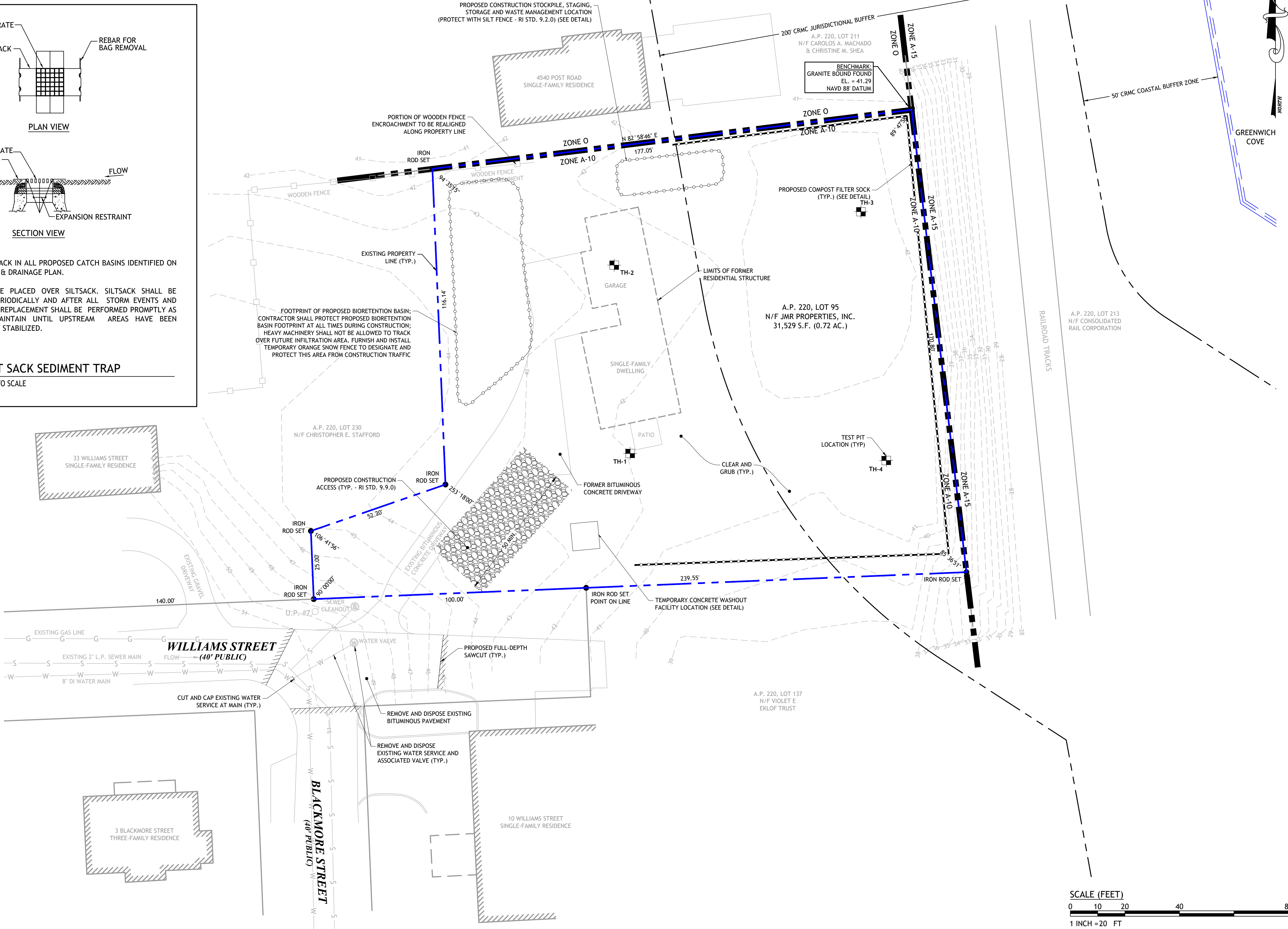

JCE
JOE CASALI ENGINEERING, INC.
CIVIL ENGINEER
300 POST ROAD, WARWICK, RI 02888
(401) 944-1300

JOSEPH A. CASALI
No. 7250
REGISTERED PROFESSIONAL ENGINEER
CIVIL
12/5/2023

GREENWICH BAY TOWNHOUSES
5 WILLIAMS STREET
WARWICK, RHODE ISLAND
AP 220, LOT 95

REVISIONS:

NO.	DATE	DESCRIPTION
R1	1/9/22	REV SETBACKS
R2	7/2023	PERMIT SET
R3	12/2023	CITY COMMENTS

DESIGNED BY:	WMLR
DRAWN BY:	SEP
CHECKED BY:	JAC
DATE:	20-10b
PROJECT NO.:	NOV. 2022

PRELIMINARY, NOT FOR CONSTRUCTION

EXISTING CONDITIONS & SITE PREP. PLAN

SHEET 3 OF 9

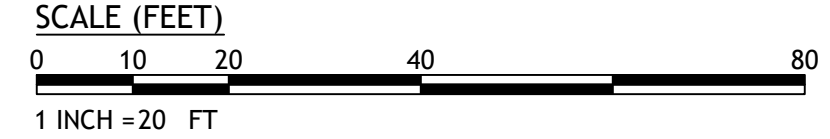

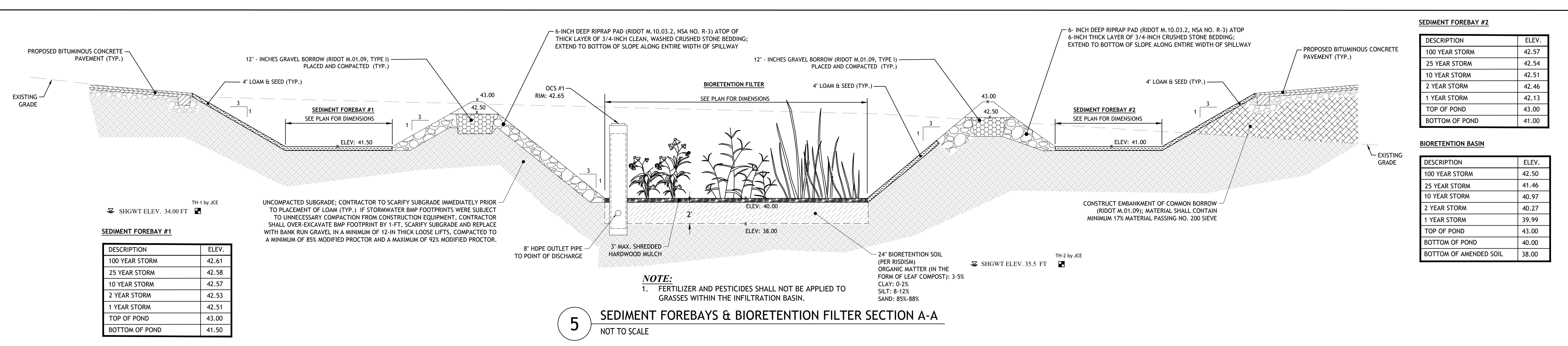

DESCRIPTION	ELEV.
100 YEAR STORM	42.61
25 YEAR STORM	42.58
10 YEAR STORM	42.57
2 YEAR STORM	42.53
1 YEAR STORM	42.51
TOP OF POND	43.00
BOTTOM OF POND	41.50

DESCRIPTION	ELEV.
100 YEAR STORM	42.50
25 YEAR STORM	41.46
10 YEAR STORM	40.97
2 YEAR STORM	40.27
1 YEAR STORM	39.99
TOP OF POND	43.00
BOTTOM OF POND	40.00
BOTTOM OF AMENDED SOIL	38.00

DESCRIPTION	ELEV.
100 YEAR STORM	42.57
25 YEAR STORM	42.54
10 YEAR STORM	42.51
2 YEAR STORM	42.46
1 YEAR STORM	42.13
TOP OF POND	43.00
BOTTOM OF POND	41.00

5 SEDIMENT FOREBAYS & BIORETENTION FILTER SECTION A-A
NOT TO SCALE

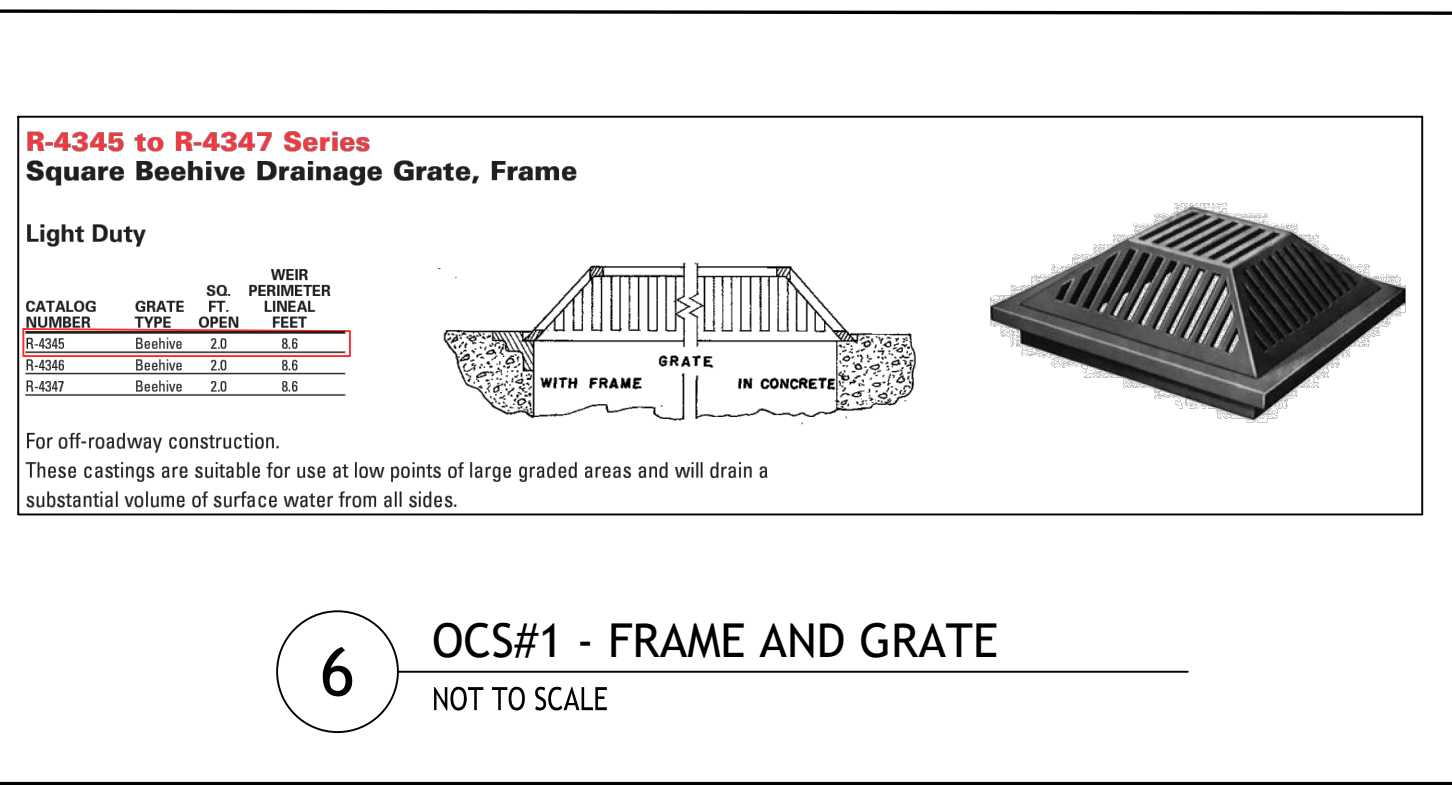

6 OCS#1 - FRAME AND GRATE
NOT TO SCALE

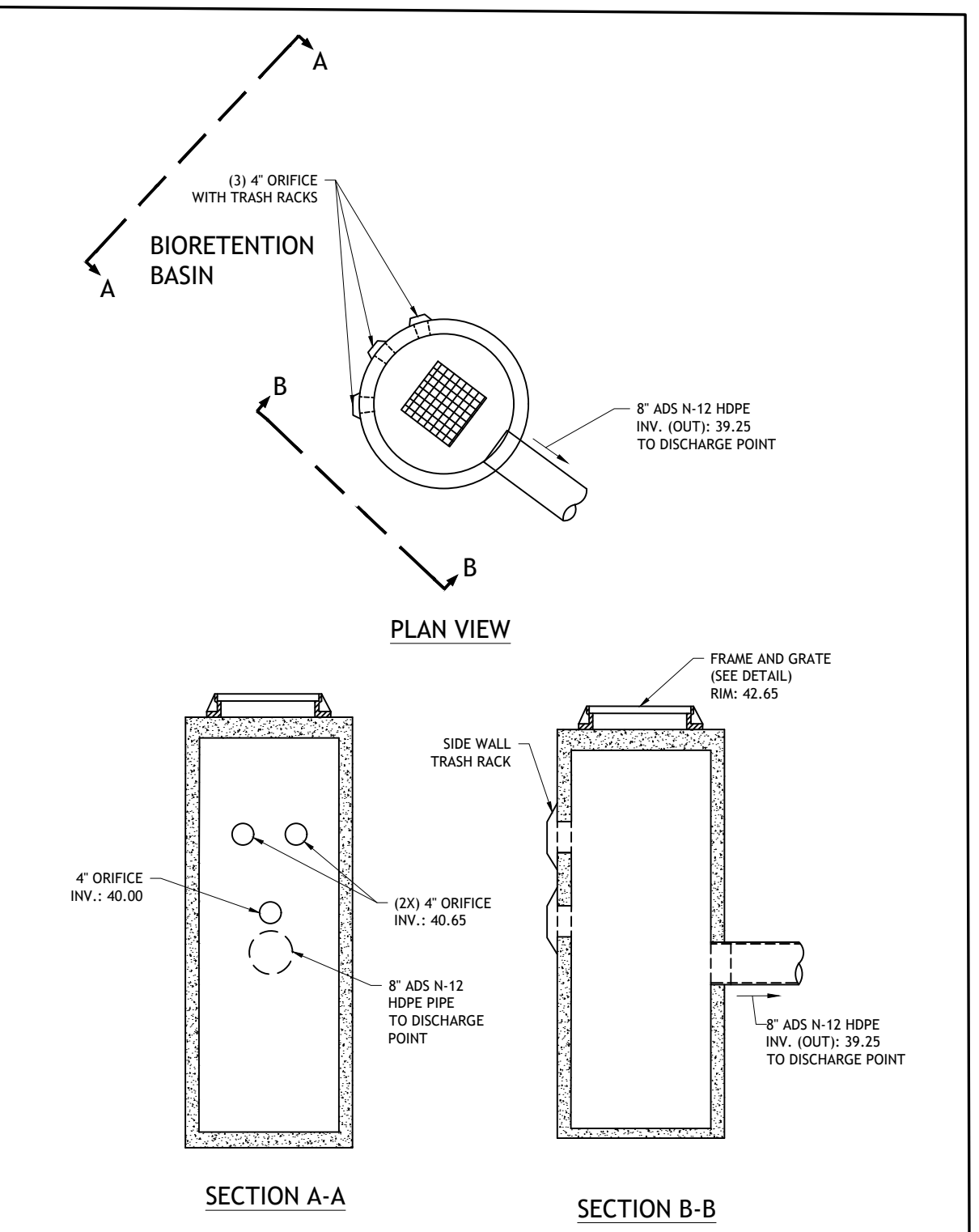

7 PROPOSED OCS #1 DETAIL
NOT TO SCALE

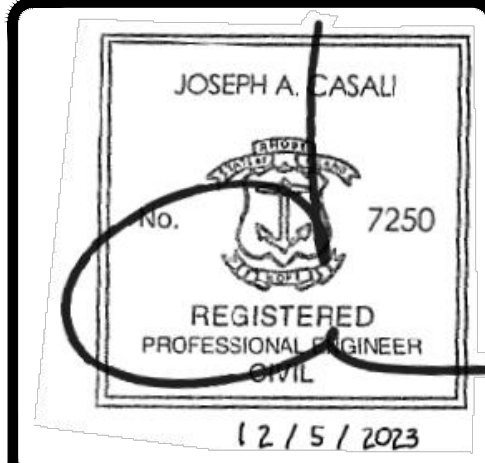
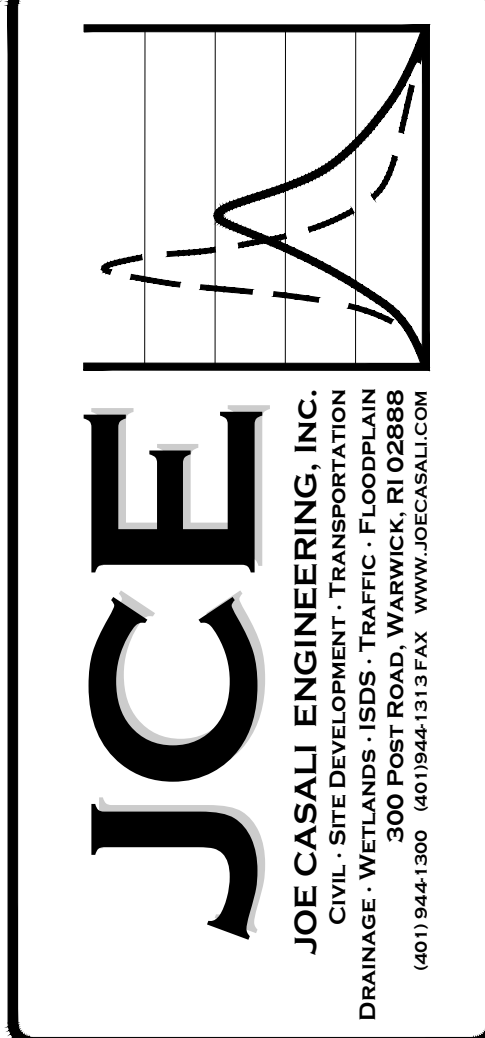
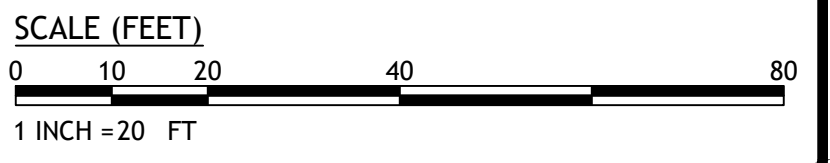

GREENWICH BAY TOWNHOUSES
5 WILLIAMS STREET
WARWICK, RHODE ISLAND
AP 220, LOT 95

NO.	DATE	DESCRIPTION
R1	1/9/23	REV SETBACKS
R2	7/2023	PERMIT SET
R3	12/2023	CITY COMMENTS

DESIGNED BY:	WMLJR
DRAWN BY:	SEP
CHECKED BY:	JAC
DATE:	20-10b
PROJECT NO.:	NOV. 2022

PRELIMINARY, NOT FOR CONSTRUCTION

GRADING & DRAINAGE PLAN

SHEET 5 OF 9

C:\2023\10\Steven Miller\23-10b-Williams Mill\23-10b-Williams Street\CAD\Williams St, Warwick, [Preliminary Plan] - R1.dwg Dec. 07, 2023 9:24am

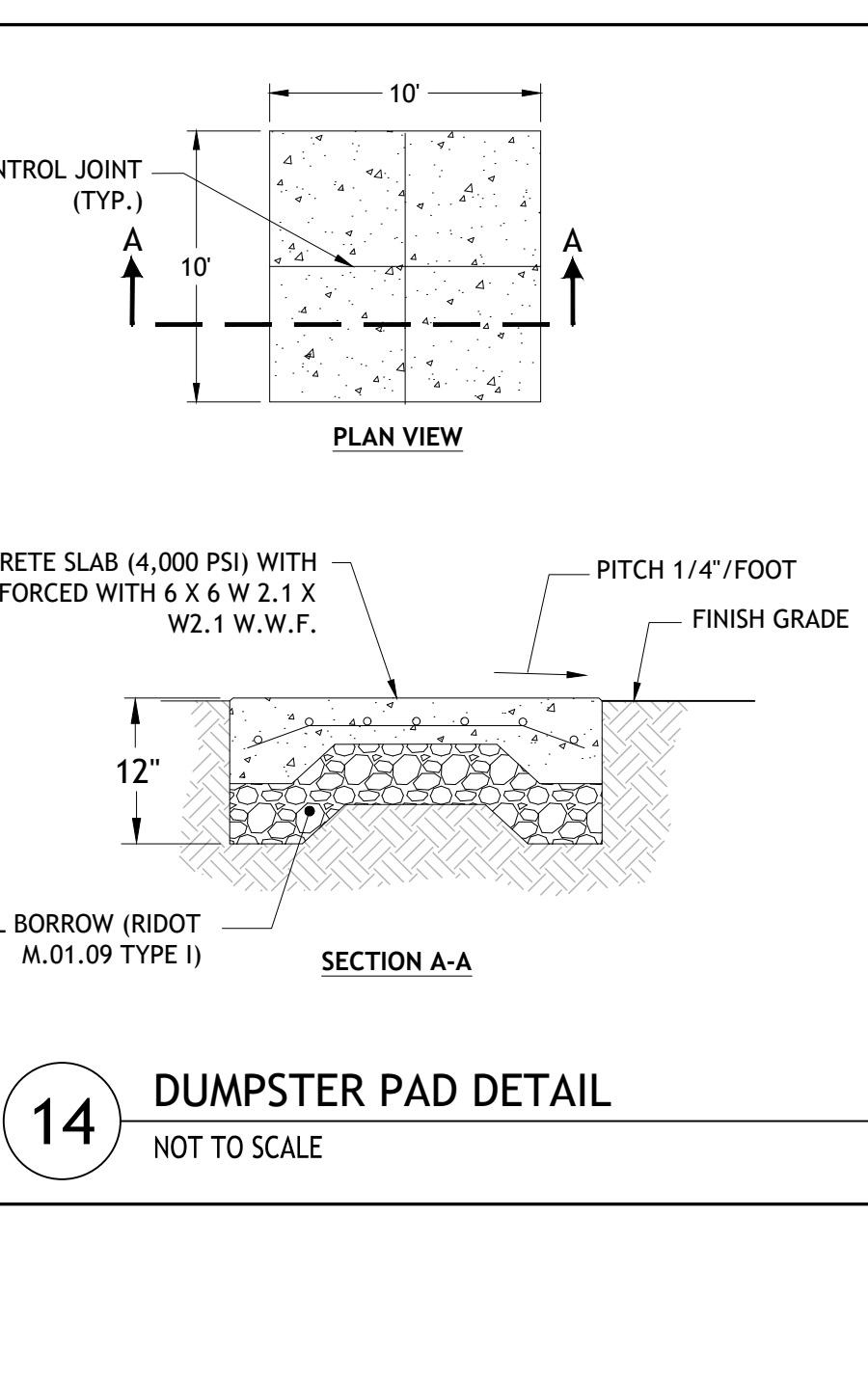
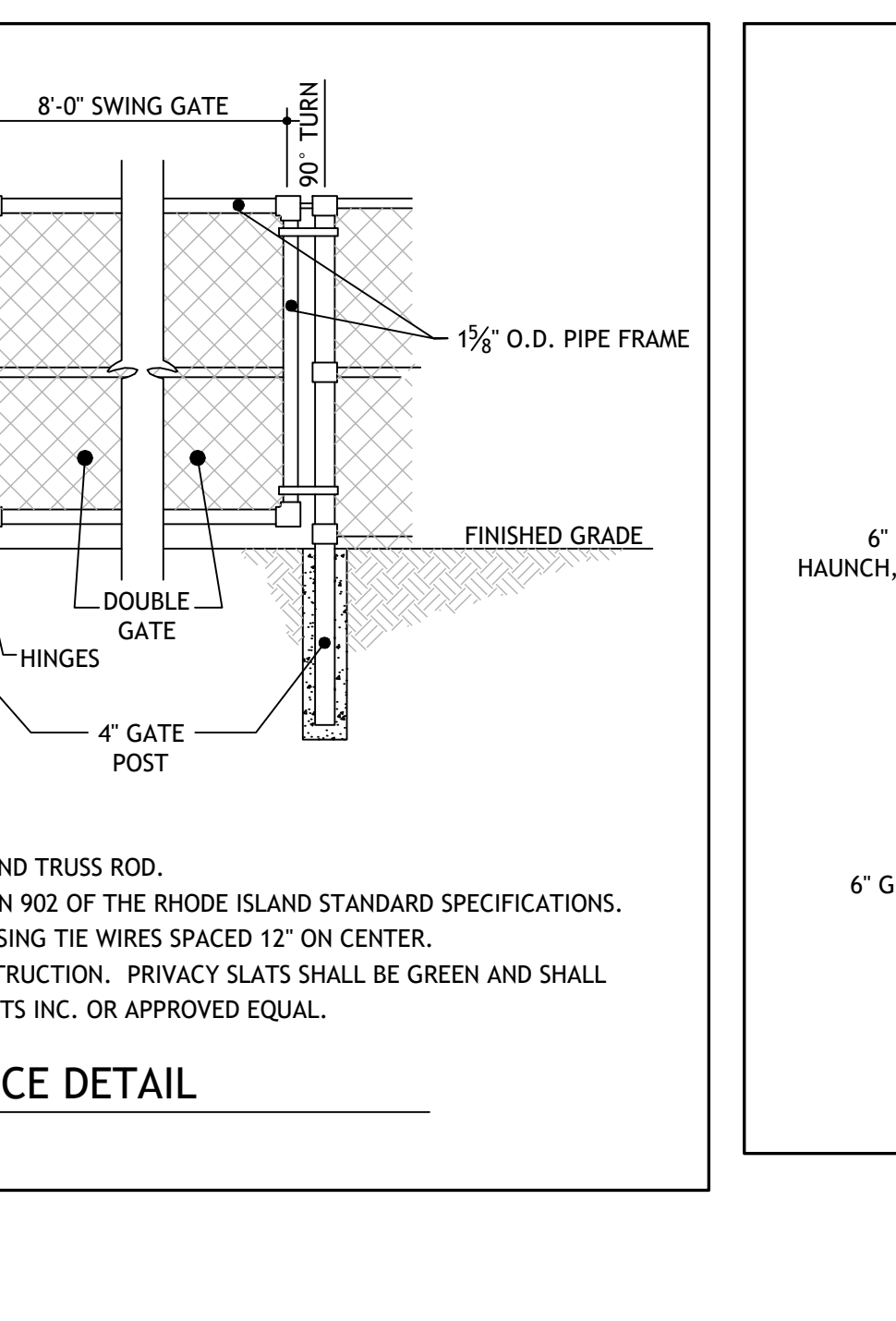
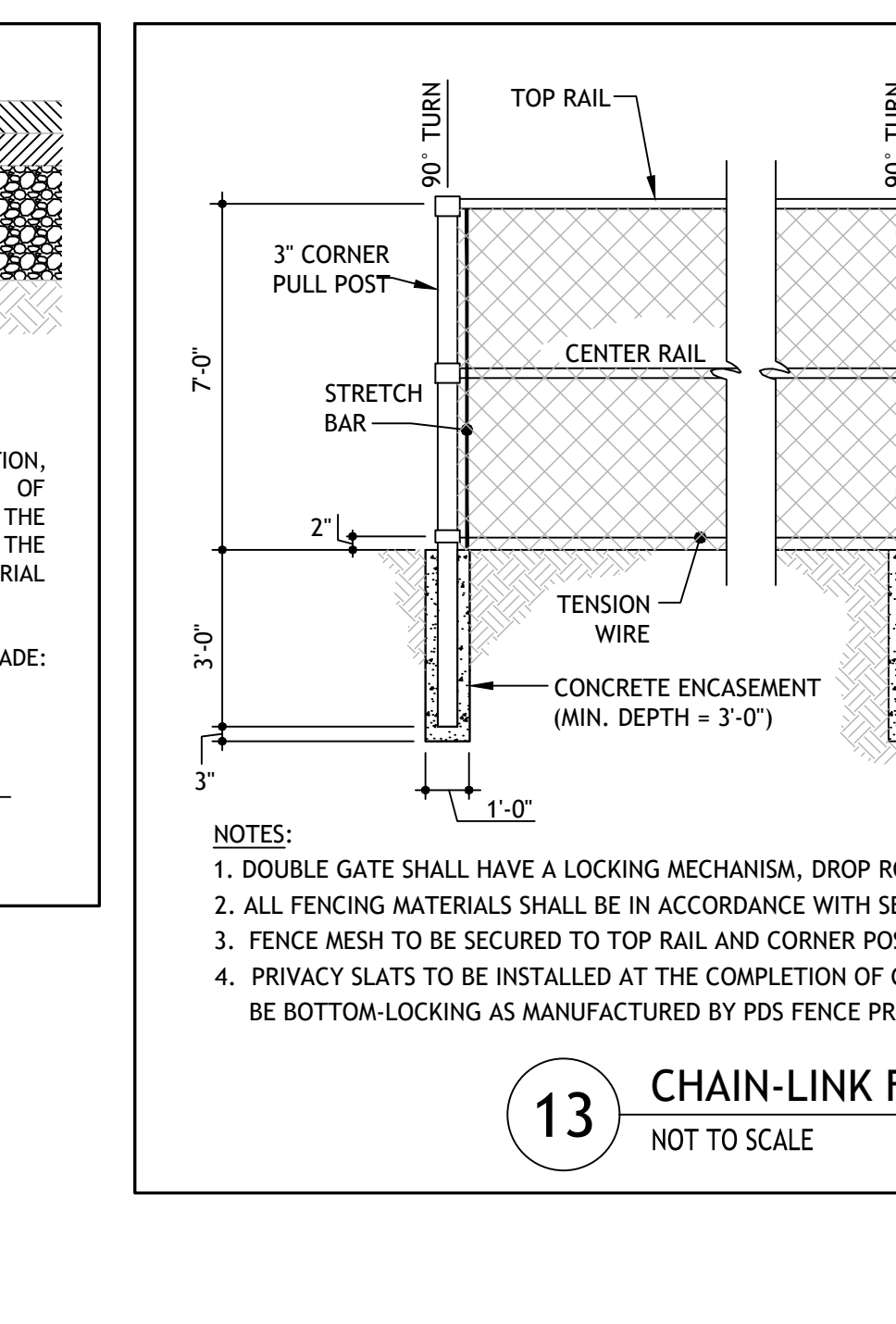
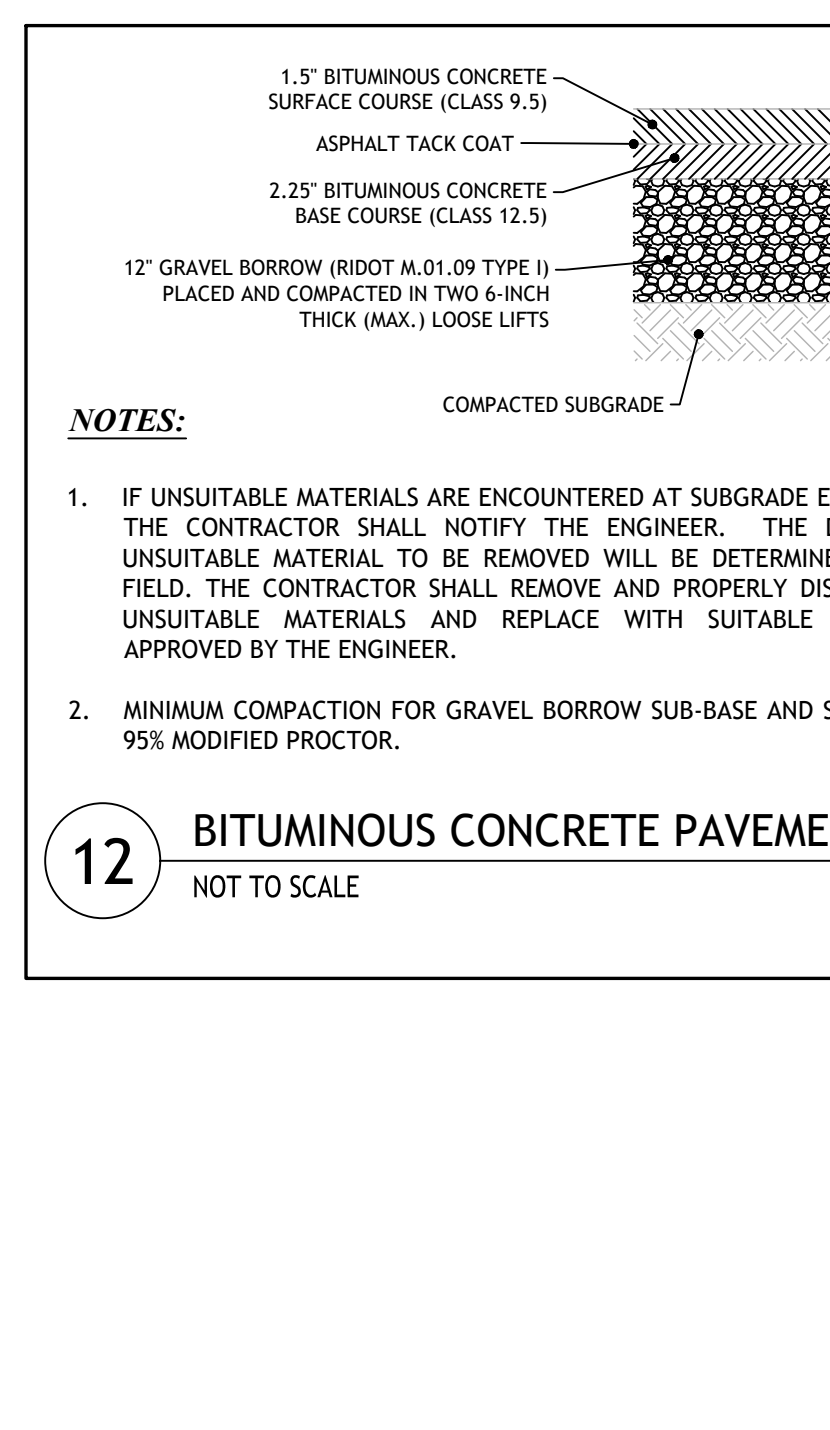
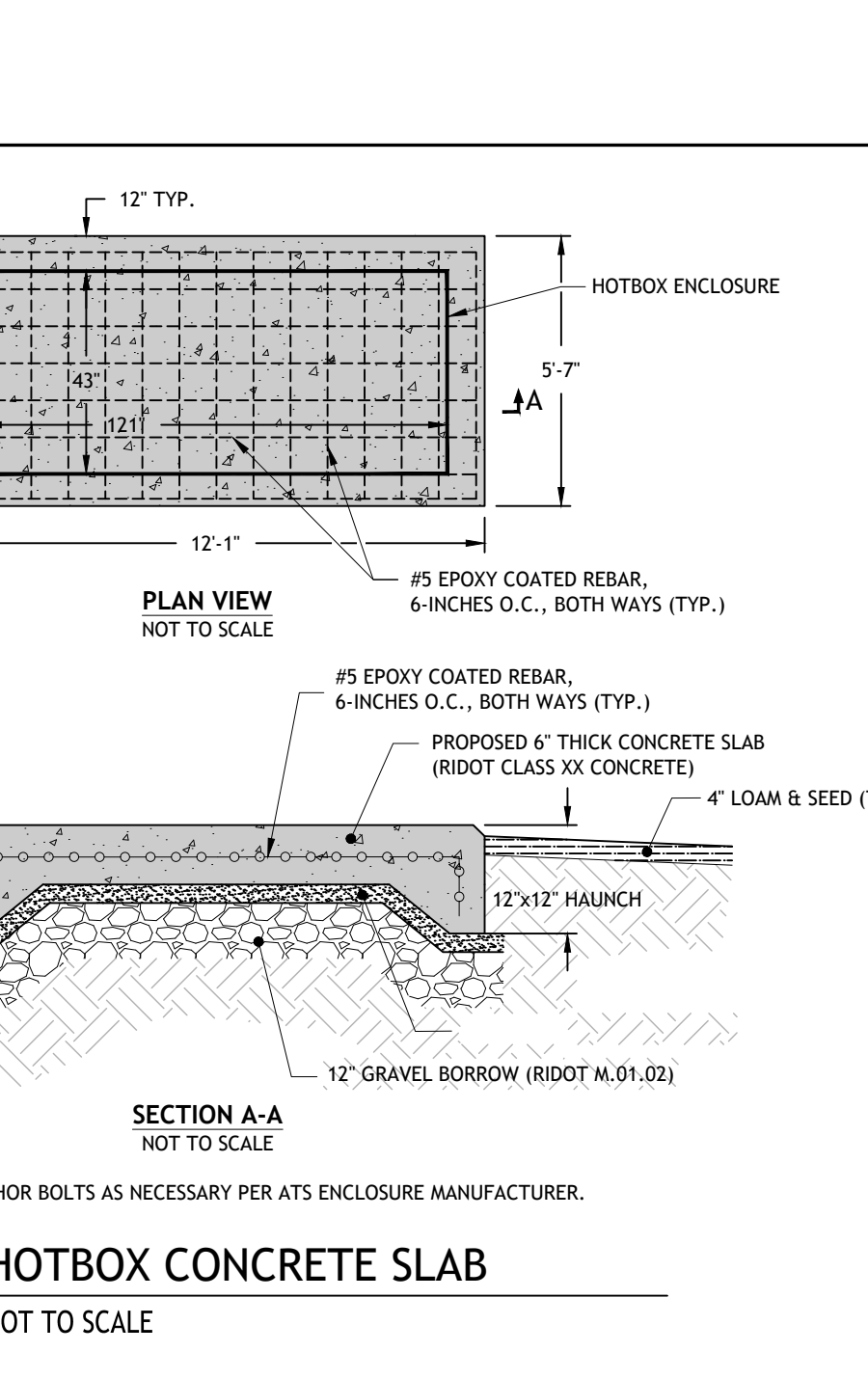
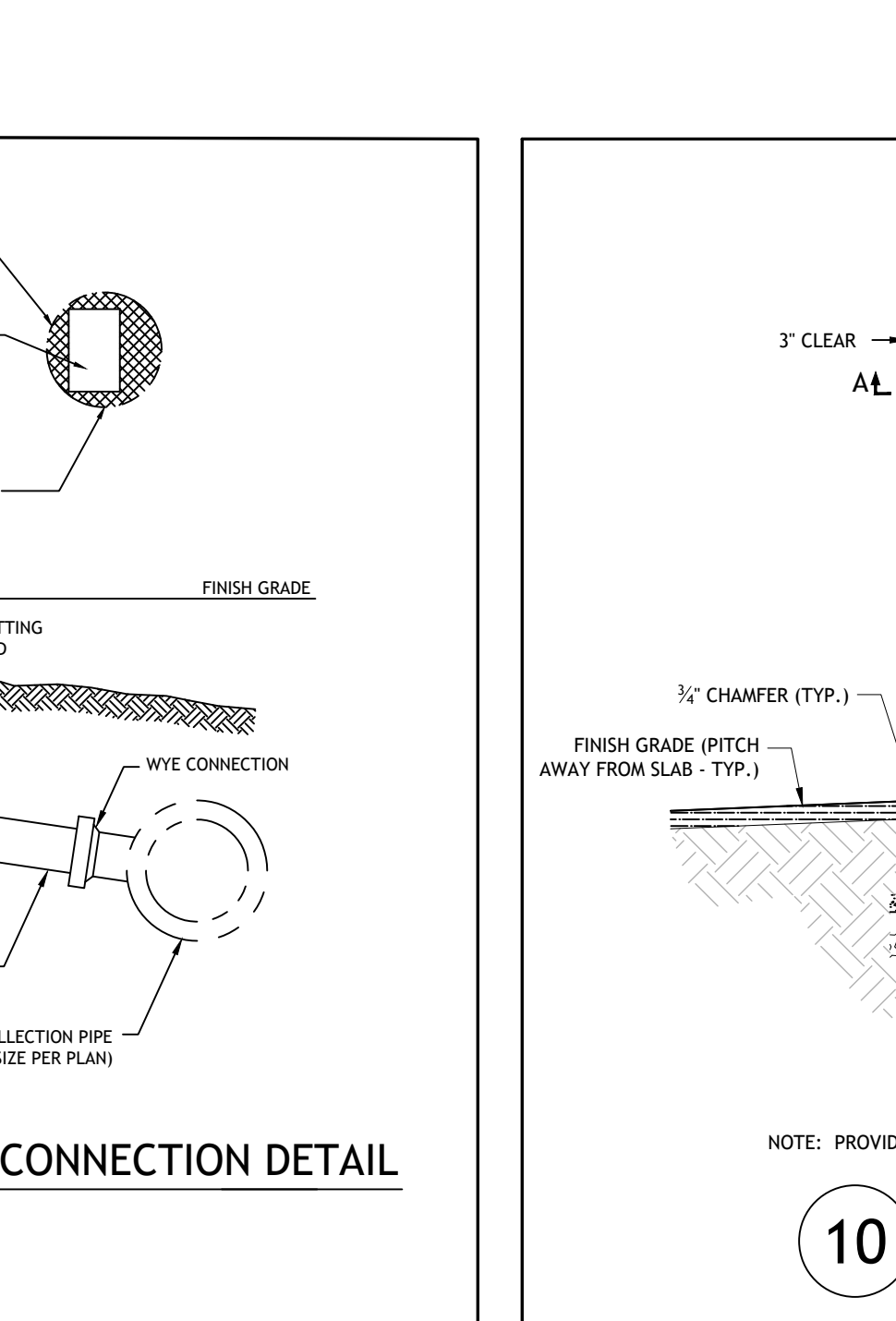
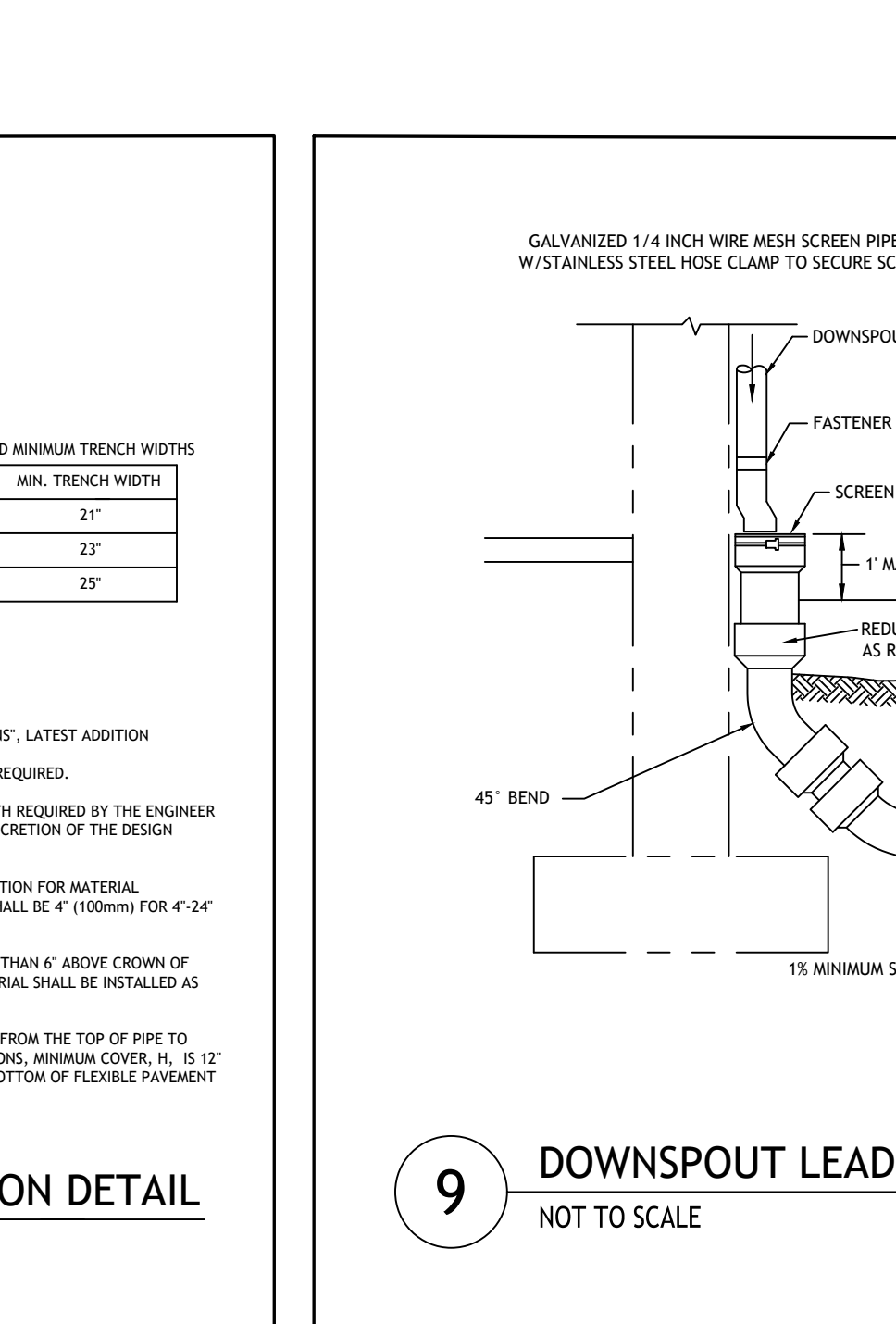
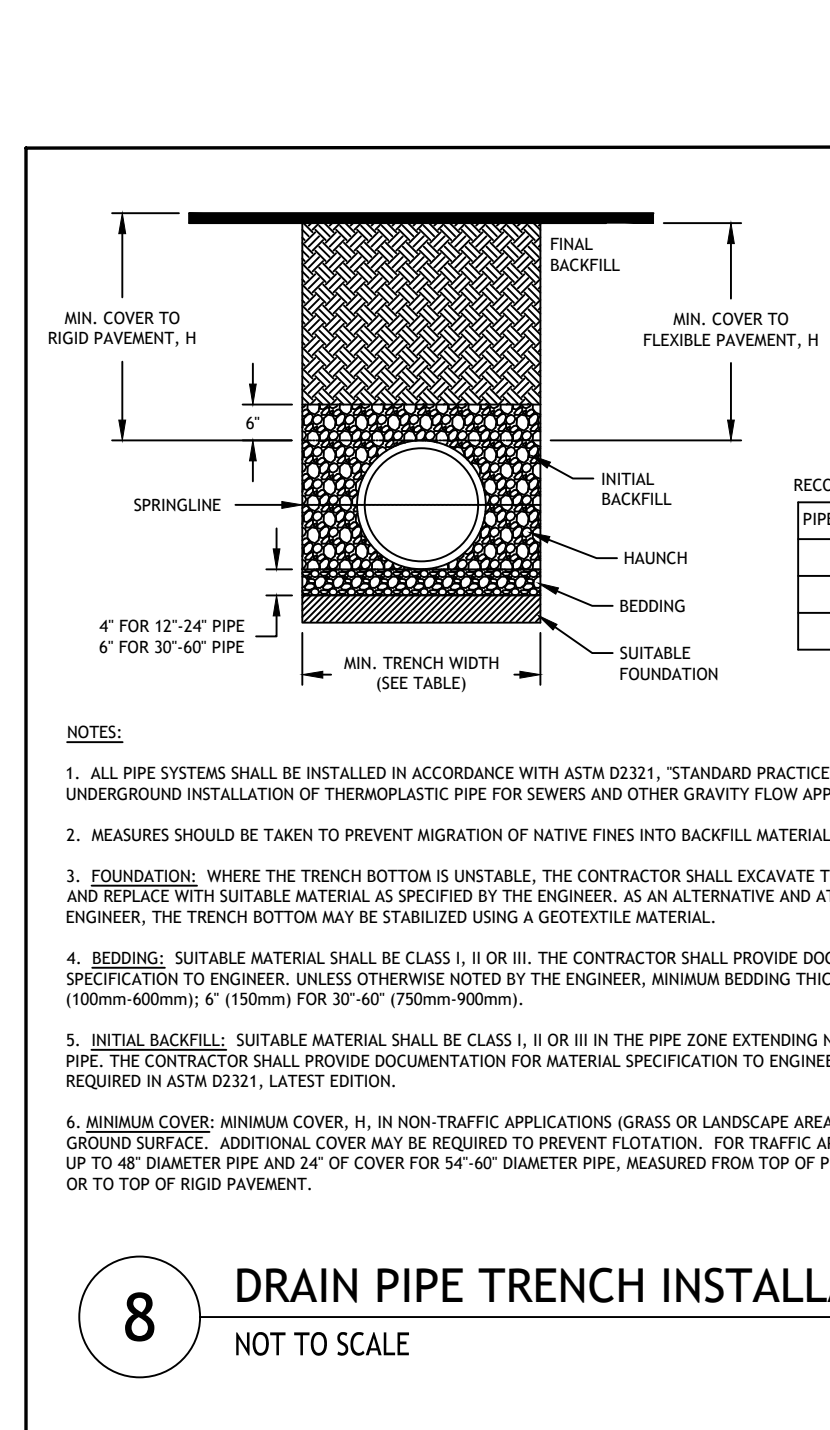
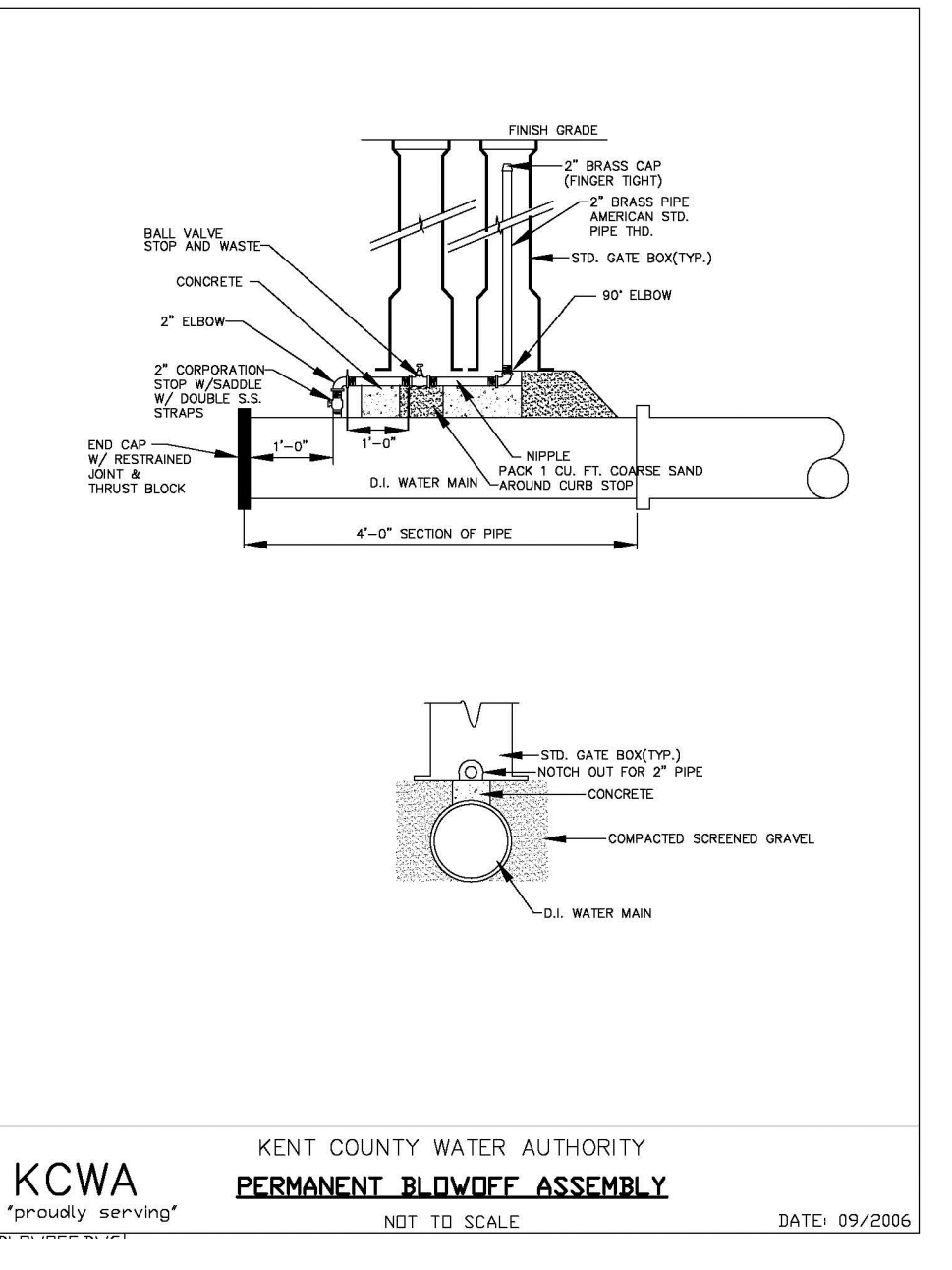
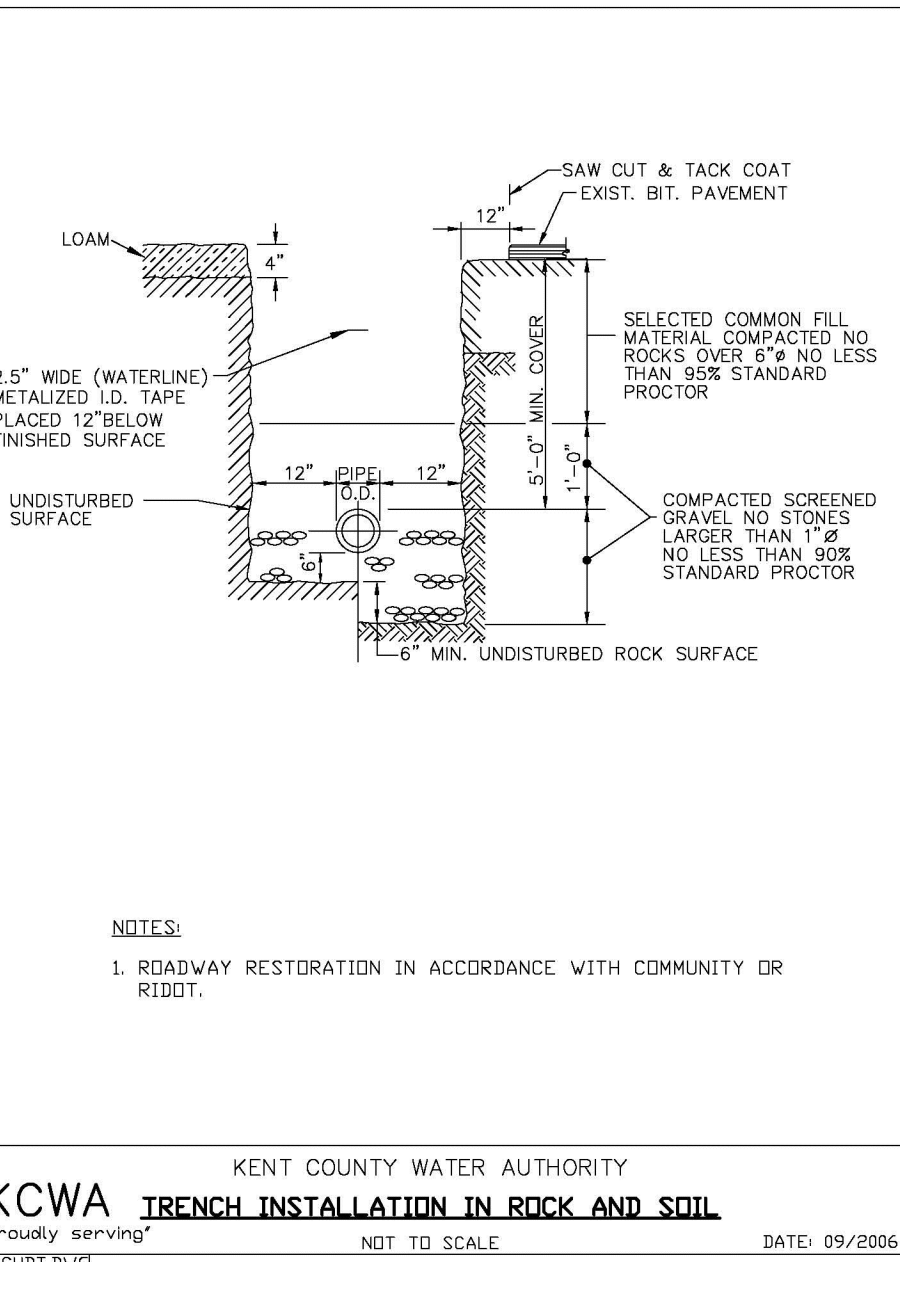
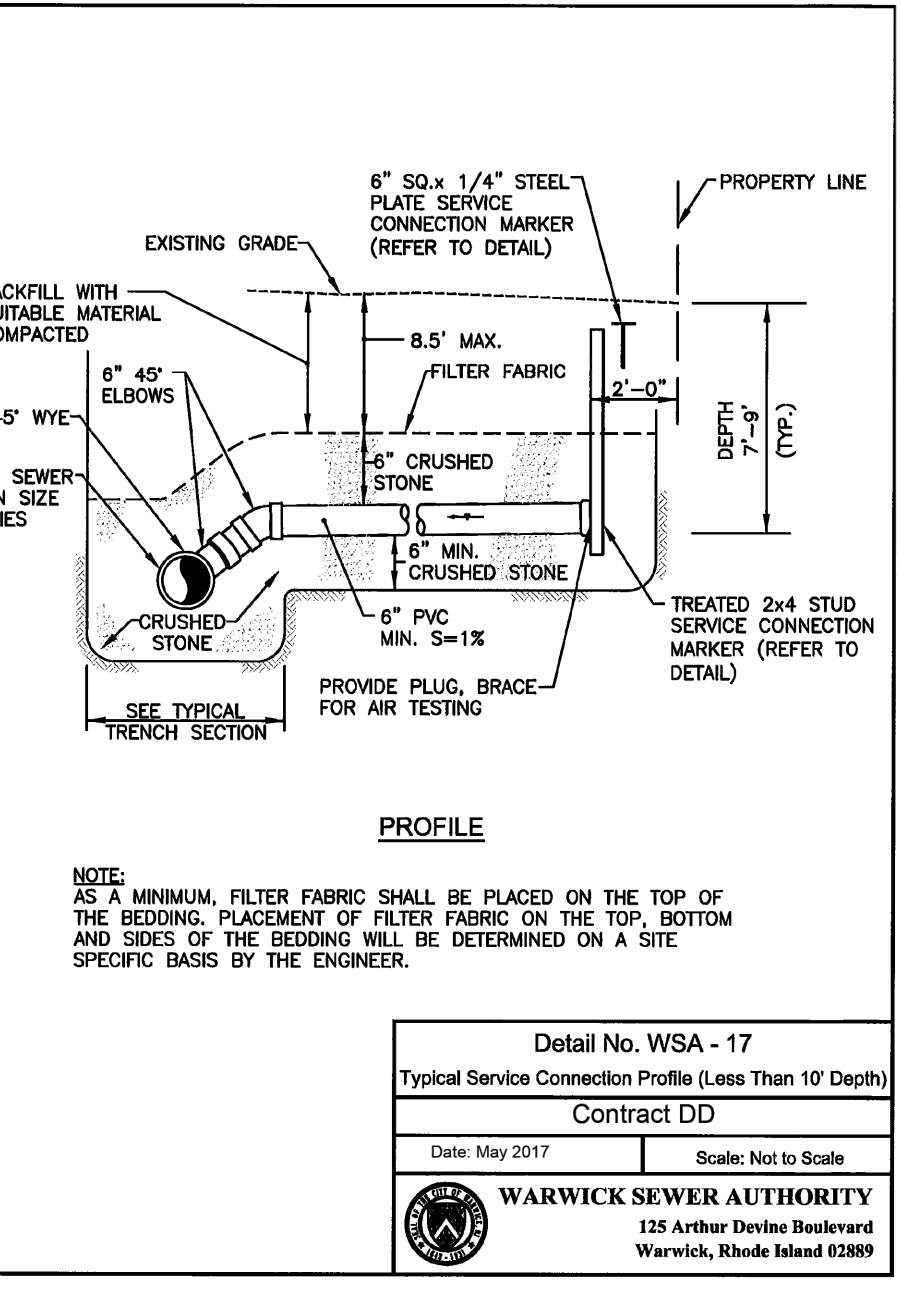
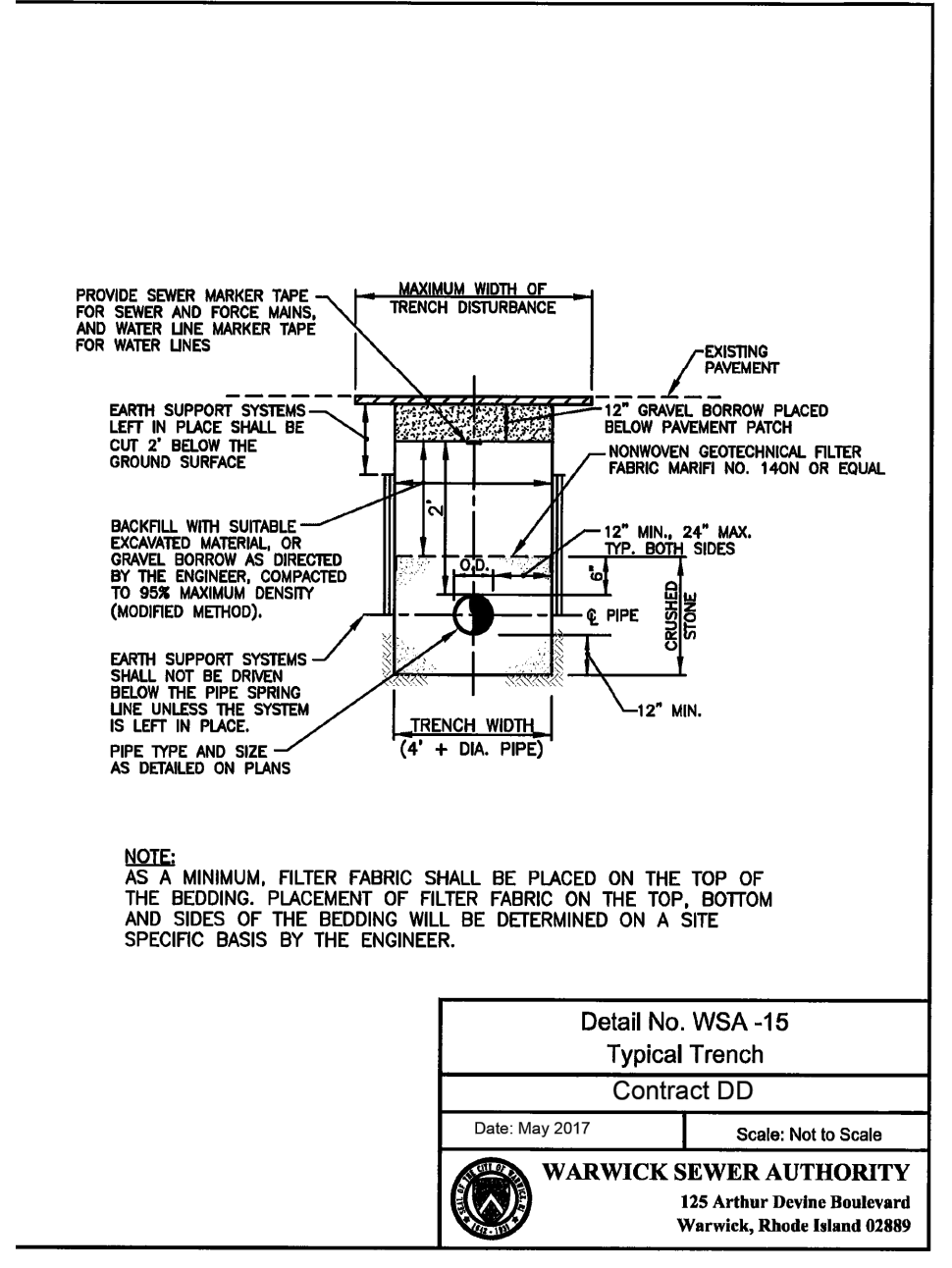
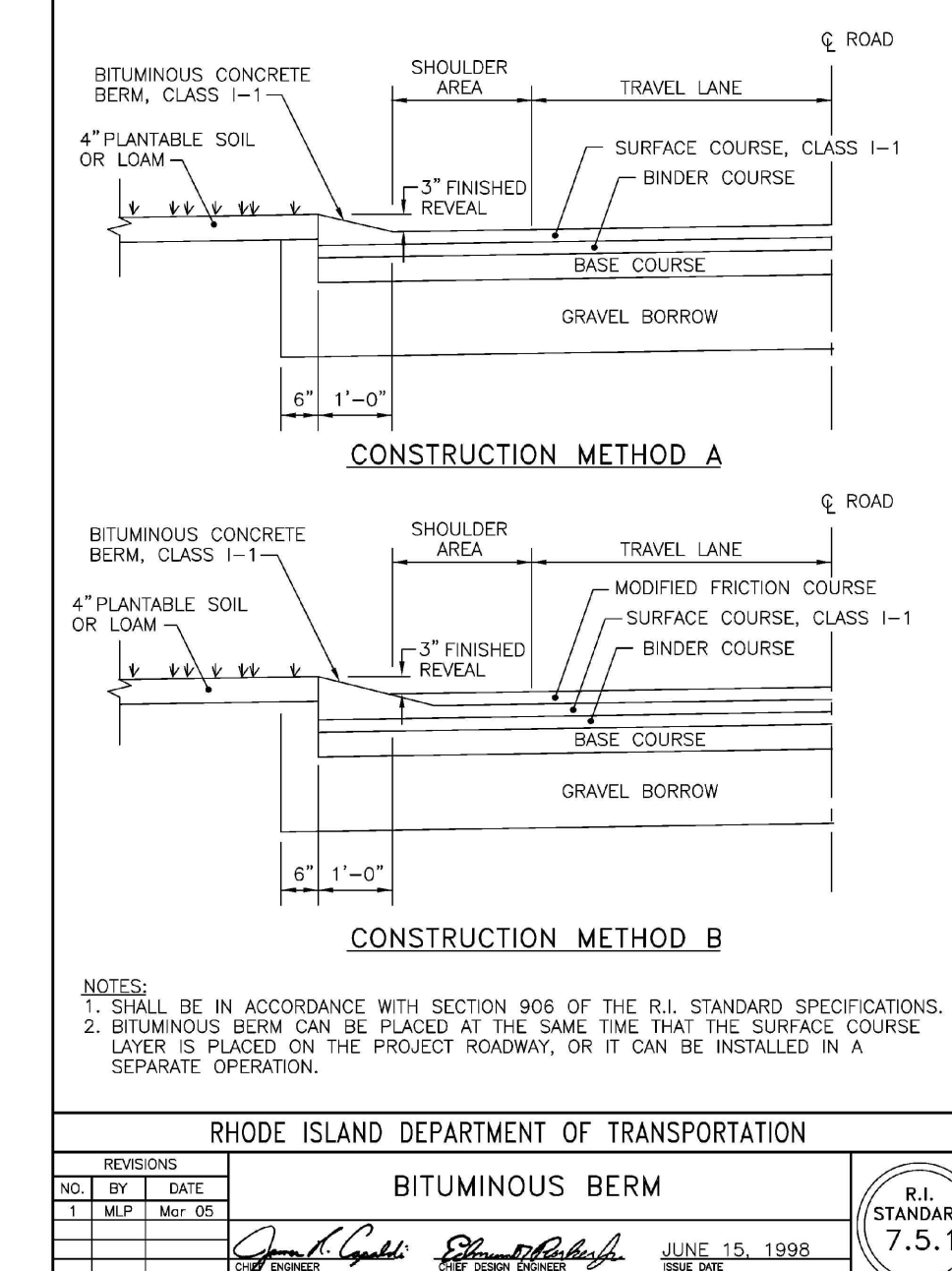
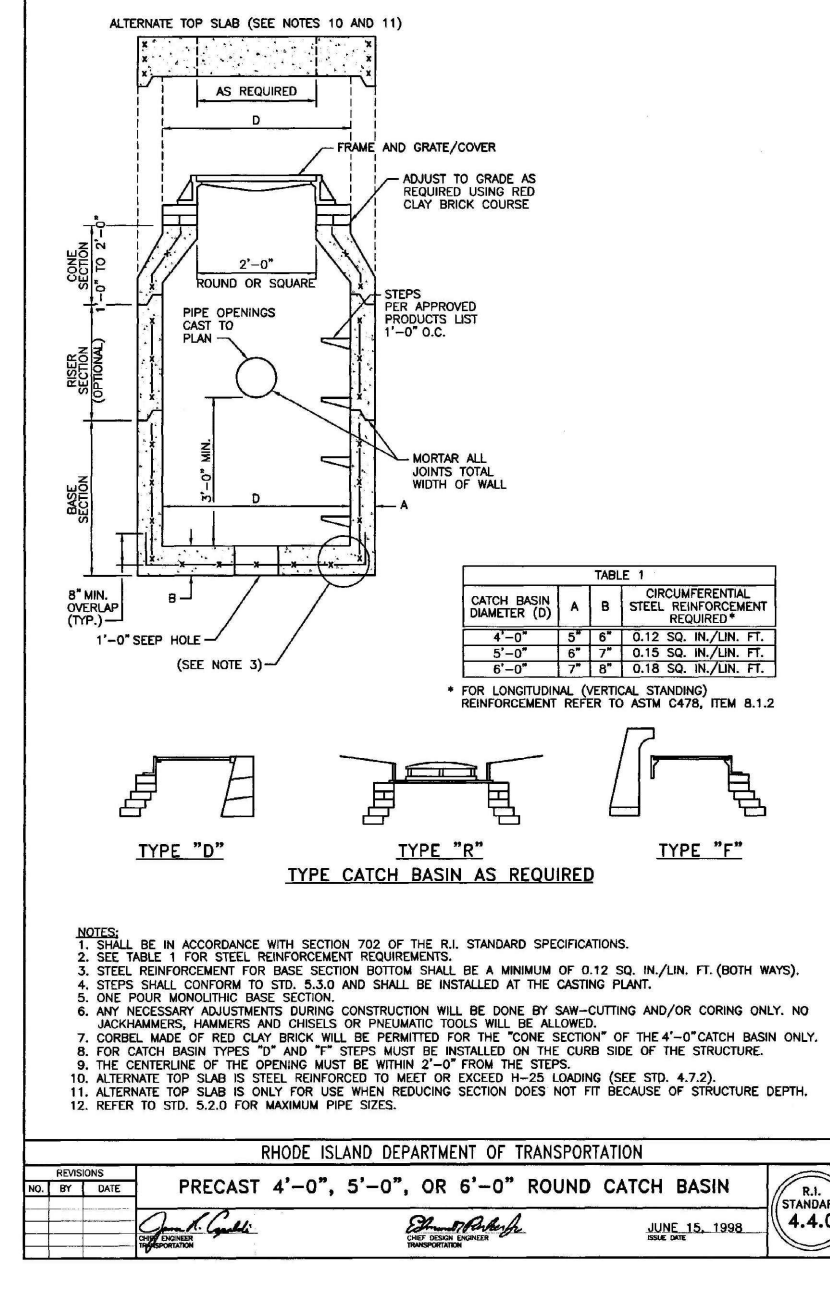

JCE
 JOE CASALI ENGINEERING, INC.
 CIVIL ENGINEERING & ARCHITECTURE
 300 POST ROAD, WARWICK, RI 02888
 (401) 844-1300 (401) 844-1313 FAX WWW.JOECASALI.COM

JOSEPH A. CASALI
 No. 7250
 REGISTERED PROFESSIONAL ENGINEER
 CIVIL
 12/5/2023

GREENWICH BAY TOWNHOUSES
 5 WILLIAMS STREET
 WARWICK, RHODE ISLAND
 AP 220, LOT 95

REVISIONS:

NO.	DATE	DESCRIPTION
R1	1/9/22	REV SETBACKS
R2	7/2023	PERMIT SET
R3	12/2023	CITY COMMENTS

DESIGNED BY: WMLR
 DRAWN BY: SEP
 CHECKED BY: JAC
 DATE: 20-10b
 PROJECT NO: NOV. 2022

PRELIMINARY, NOT FOR CONSTRUCTION

DETAILS I

SHEET 7 OF 9

C:\2023\10\Greenwich\10-Williams-Street\CAD\Williams-St., Warwick, [Preliminary Plan] - R1.dwg, Dec. 07, 2023 9:42am

REFERENCE:
 1. DEED BK. 9859 PG. 229
 2. "ADMINISTRATIVE SUBDIVISION ASSESSOR'S PLAT 220, LOTS 230, 95, 137 WARWICK, RHODE ISLAND SCALE: 1"=30' DECEMBER 03, 2001. PREPARED FOR FRANK EKLOF PREPARED BY OCEAN STATE PLANNERS, INC."



GRANITE BOUND FOUND
 B.M. = 41.29
 NAVD 88' DATUM

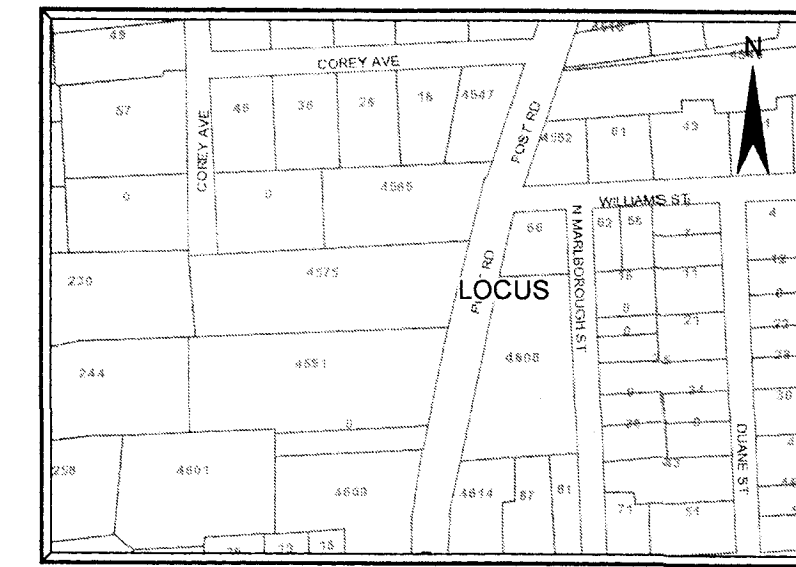

LOCUS MAP
 NOT TO SCALE

ZONING DISTRICT A-10 (PDR-L)
 MULTIPLE FAMILY
 MINIMUM LOT AREA: 30,000 S.F.
 MINIMUM LOT FRONTAGE: 155 FT.
 MINIMUM LOT WIDTH: 155 FT.
 MINIMUM SETBACKS: FRONT: 35 FT.
 SIDE: 25 FT.
 REAR: 35 FT.
 MAXIMUM DENSITY: 7.0 U./ACRE
 MAXIMUM STRUCTURE HEIGHT: 35 FT.
 MINIMUM LANDSCAPE: 25%

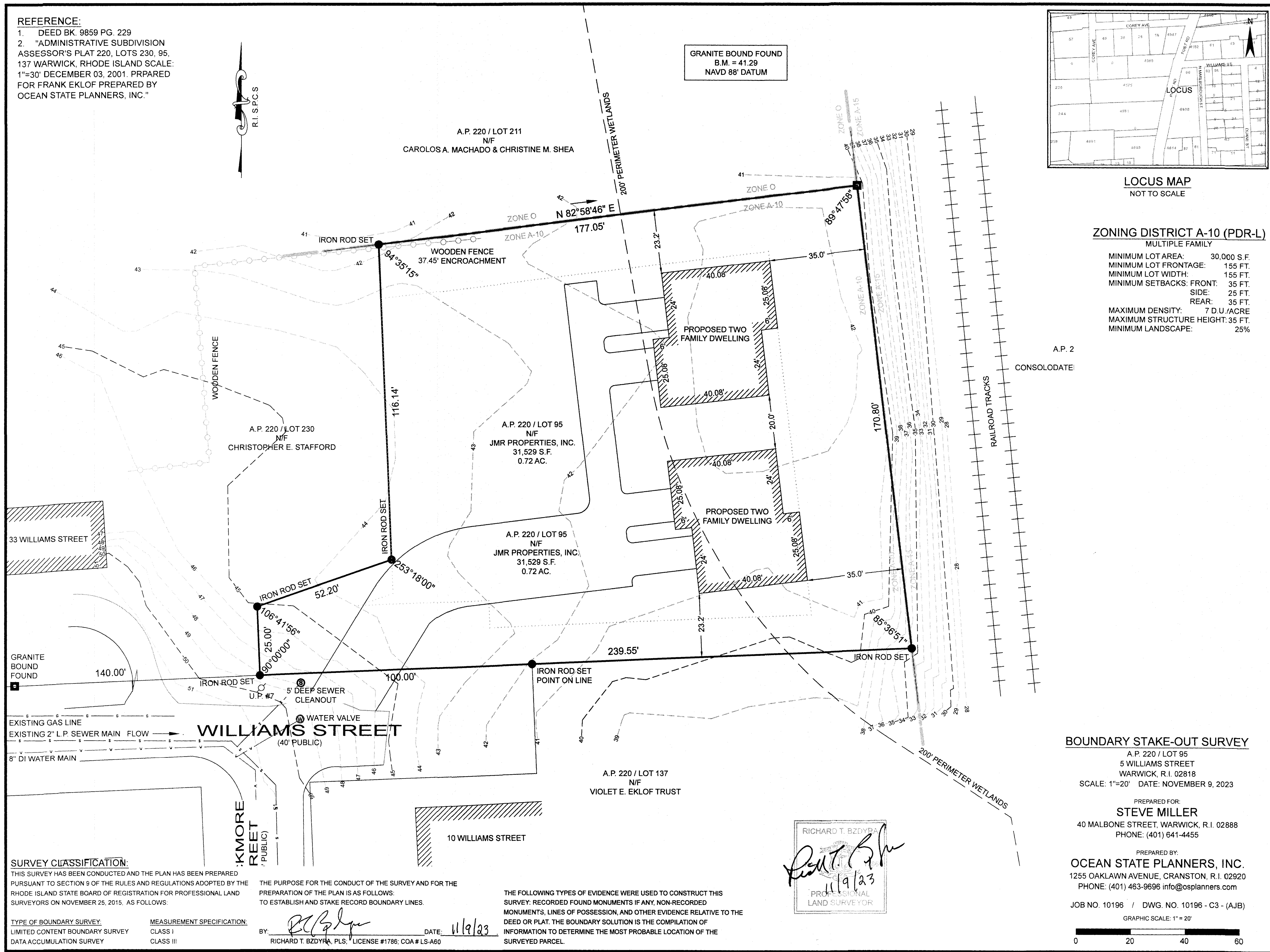

BOUNDARY STAKE-OUT SURVEY
 A.P. 220 / LOT 95
 5 WILLIAMS STREET
 WARWICK, R.I. 02818
 SCALE: 1"=20' DATE: NOVEMBER 9, 2023

PREPARED FOR:
STEVE MILLER
 40 MALBONE STREET, WARWICK, R.I. 02888
 PHONE: (401) 641-4455

PREPARED BY:
OCEAN STATE PLANNERS, INC.
 1255 OAKLAWN AVENUE, CRANSTON, R.I. 02920
 PHONE: (401) 453-9696 info@osplanners.com

JOB NO. 10196 / DWG. NO. 10196 - C3 - (AUB)
 GRAPHIC SCALE: 1" = 20'

SURVEY CLASSIFICATION:
 THIS SURVEY HAS BEEN CONDUCTED AND THE PLAN HAS BEEN PREPARED PURSUANT TO SECTION 9 OF THE RULES AND REGULATIONS ADOPTED BY THE RHODE ISLAND STATE BOARD OF REGISTRATION FOR PROFESSIONAL LAND SURVEYORS ON NOVEMBER 25, 2015. AS FOLLOWS:

TYPE OF BOUNDARY SURVEY: LIMITED CONTENT BOUNDARY SURVEY DATA ACCUMULATION SURVEY	MEASUREMENT SPECIFICATION: CLASS I CLASS III
---	--

THE PURPOSE FOR THE CONDUCT OF THE SURVEY AND FOR THE PREPARATION OF THE PLAN IS AS FOLLOWS:
 TO ESTABLISH AND STAKE RECORD BOUNDARY LINES.

BY: *[Signature]* DATE: 11/9/23
 RICHARD T. BZDYRA, PLS., LICENSE #1788, COA # LS-A60

THE FOLLOWING TYPES OF EVIDENCE WERE USED TO CONSTRUCT THIS SURVEY: RECORDED FOUND MONUMENTS IF ANY, NON-RECORDED MONUMENTS, LINES OF POSSESSION, AND OTHER EVIDENCE RELATIVE TO THE DEED OR PLAT. THE BOUNDARY SOLUTION IS THE COMPILATION OF INFORMATION TO DETERMINE THE MOST PROBABLE LOCATION OF THE SURVEYED PARCEL.

RICHARD T. BZDYRA
[Signature]
 11/9/23
 PROFESSIONAL
 LAND SURVEYOR



GREENWICH BAY TOWNHOUSES
5 WILLIAMS STREET
WARWICK, RHODE ISLAND
AP 220, LOT 95

REVISIONS:

NO.	DATE	DESCRIPTION

DESIGNED BY:	DCS
DRAWN BY:	DCS
CHECKED BY:	DCS
DATE:	20-10b
PROJECT NO.:	NOV. 2023

PRELIMINARY, NOT FOR CONSTRUCTION

LANDSCAPE DETAILS

SHEET 2 OF 2

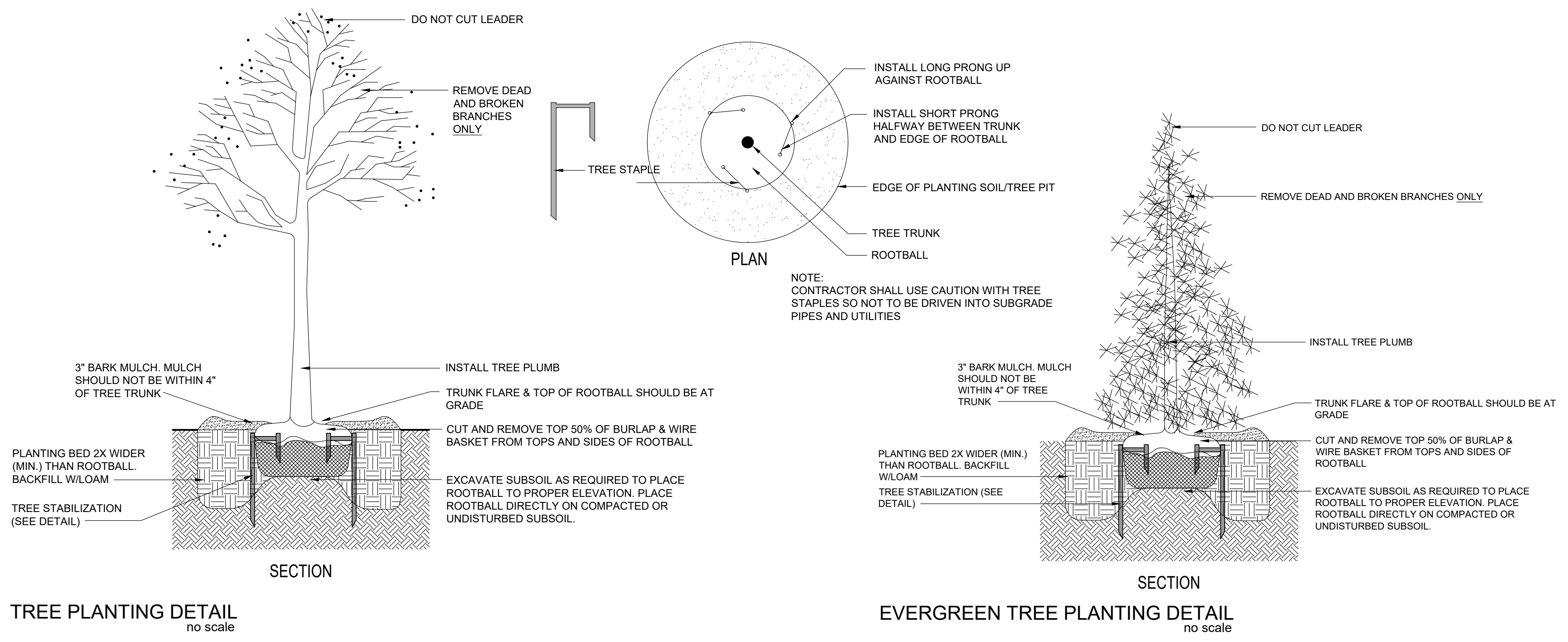

LANDSCAPE NOTES:

1. GUARANTEE THAT, UPON COMPLETION AND FINAL ACCEPTANCE, LANDSCAPE PLANTINGS CONFORM TO REQUIREMENTS OF CONTRACT DOCUMENTS. PROVIDE A WARRANTY FOR TREE PLANTINGS FOR A MINIMUM OF TWO (2) YEARS, INCLUDING TWO (2) CONTINUOUS GROWING SEASONS. COMMENCE WARRANTY ON DATE IDENTIFIED IN THE 'CERTIFICATE OF FINAL COMPLETION'.
2. REPLACEMENTS: PLANTS OF SAME SIZE AND SPECIES AS SPECIFIED, PLANTED IN THE NEXT GROWING SEASON, WITH NEW WARRANTY AND EXTENDED MAINTENANCE SERVICE COMMENCING ON THE DATE OF REPLACEMENT.
3. PLANT MATERIALS SHALL BE OF SIZE AND CALIPER REQUIRED AND CONFORM TO THE REQUIREMENTS DESCRIBED IN THE LATEST EDITION OF AMERICAN STANDARD FOR NURSERY STOCK, PUBLISHED BY THE AMERICAN ASSOCIATION OF NURSERYMEN.
4. PLANTS OF OTHER KINDS THAN THOSE NAMED IN THE PLANT SCHEDULE SHALL NOT BE ACCEPTED WITHOUT APPROVAL. REPLACEMENT PLANTS LARGER IN SIZE THAN EXISTING MAY BE USED IF APPROVED BY THE A/E, PROVIDED USE OF LARGER PLANTS DOES NOT INCREASE CONTRACT PRICE.
5. A PROFESSIONAL HORTICULTURIST/NURSERYMAN SHALL BE CONSULTED TO DETERMINE THE PROPER TIME TO MOVE AND INSTALL PLANT MATERIAL SO THAT STRESS TO THE PLANT IS MINIMIZED. PLANTING OF DECIDUOUS MATERIAL MAY BE CONTINUED DURING WINTER MONTHS PROVIDED THERE IS NO FROST IN THE GROUND AND FROST-FREE TOPSOIL PLANTING MIXTURES ARE USED.
6. UNLESS OTHERWISE APPROVED BY THE A/E, ALL PLANTS SHALL BE NURSERY GROWN IN ACCORDANCE WITH GOOD HORTICULTURAL PRACTICES AND SHALL HAVE BEEN GROWN UNDER CLIMATIC CONDITIONS SIMILAR TO THOSE IN THE LOCALITY OF THE PROJECT FOR AT LEAST TWO (2) YEARS.
7. SET PLANTS PLUMB AND AT SUCH A LEVEL THAT AFTER SETTLEMENT THEY BEAR THE SAME RELATION TO THE SURROUNDING GROUND AS THEY BORE TO THE GROUND FROM WHICH THEY WERE DUG. SETTLE BACKFILL MATERIAL FOR PLANTS, THOROUGHLY & PROPERLY, BY FIRING OR TAMPING. ACCOMPANY BACKFILLING WITH THOROUGH WATERING UNLESS OTHERWISE APPROVED. FORM SAUCER CAPABLE OF HOLDING WATER AROUND INDIVIDUAL PLANTS.
8. FERTILIZE SHRUB BEDS WITH 10-6-4 FERTILIZER AT THE RATE OF 3 POUNDS PER 100 SQUARE FEET OF SURFACE AREA, BROAD CAST. APPLY THE FERTILIZER UNIFORMLY TO THE SURFACE BEDS AND WORK INTO THE UPPER TWO (2) INCHES OF SOIL. FERTILIZE INDIVIDUAL TREES AT THE RATE OF ONE (1) AGRIFORM PELLETT PER INCH OF TREE DIAMETER (FOLLOW MANUFACTURER'S WRITTEN INSTRUCTIONS). APPLY A SECOND APPLICATION OF FERTILIZER TO ALL PLANT ITEMS AT THE SAME SPECIFIED RATES OVER THE MULCH AT THE END OF AN EIGHT WEEK PERIOD.
9. CONTAINER GROWN MATERIALS: REMOVE PLANT FROM CONTAINER AND "BUTTERFLY" ROOT BALL OR OTHERWISE SPREAD OUT ROOTS ON SETTING MOUND. BACKFILL SHALL BE SIFTED THROUGH THEM AND SOLIDLY FIRMED.
10. AFTER PLANTING PRUNE ONLY BROKEN OR DEFORMED BRANCHES AND IN SUCH MANNER AS TO PRESERVE NATURAL CHARACTER OF PLANT.
11. IMMEDIATELY AFTER PLANTING, STAKE TREES OVER FIVE (5) FEET AS INDICATED ON DETAIL DRAWING INDICATED OR APPROVED BY THE OWNERS REPRESENTATIVE. MULCH SHALL BE APPLIED A MINIMUM OF THREE (3) INCHES IN DEPTH IN ALL PLANTING BEDS, AS INDICATED ON THE DRAWINGS.
12. THE PLANTS SHALL BE WATERED IMMEDIATELY FOLLOWING PLANTING, PREFERABLY WHEN TWO THIRDS OF THE BACKFILL HAS BEEN PLACED SO ALL AIR POCKETS ARE REMOVED AND THE PLANT PROPERLY SET. ADDITIONAL WATERING SHALL BE MADE AT LEAST ONCE EVERY THREE (3) WEEKS UNLESS OTHERWISE DIRECTED UNTIL FINAL ACCEPTANCE OF THE PLANT MATERIAL.
13. INSTALL 'JUTE MESH' EROSION CONTROL FABRIC WHERE FINAL GRADES ARE 3:1 (33%) OR GREATER PER MANUFACTURER'S INSTRUCTIONS.
14. UNLESS OTHERWISE SPECIFIED, CONTRACTOR TO LOAM AND SEED ALL DISTURBED AREAS. **SEEDING NOTE:** USE UNIVERSITY OF RHODE ISLAND NO. 2 IMPROVED SEED MIX OR EQUAL. **TREE PRUNING NOTE:** STREET TREES SHOULD BE PRUNED TO MAINTAIN A MINIMAL BRANCH HEIGHT OF 8' WITHIN TWO (2) YEARS OF INSTALLATION OF THE TREE.
15. **LANDSCAPE ESTABLISHMENT AND MAINTENANCE NOTE:** CONTRACTOR SHALL ENSURE THAT ALL LAWN AREAS AND PLANTINGS ARE FULLY ESTABLISHED AND ACCEPTABLE TO THE OWNER'S REPRESENTATIVE PRIOR TO RELINQUISHING THEIR RESPONSIBILITIES FOR MAINTENANCE OF THESE AREAS.
16. **TREE PROTECTION NOTE:** NO MATERIAL, TEMPORARY SOIL DEPOSIT OR EXCAVATION SHALL OCCUR WITHIN FOUR FEET OF SHRUBS OR WITHIN TWO FEET OF THE DRIP LINE OF ANY SHRUBS OR TREES TO REMAIN. ANY RETAINED EXISTING VEGETATION SHALL BE PROTECTED AS PER DETAIL ON PLAN.

D:\ALL MASTER FILES\DRAWINGS\GREENWICH\Greenwich Street\Williams St. Warwick\Preliminary\Plan\Standard\CD\Williams St. Warwick LANDSCAPE 11.07.23.dwg, Nov. 08, 2023 2:13pm