

#10899 - 72 Shawomet Ave

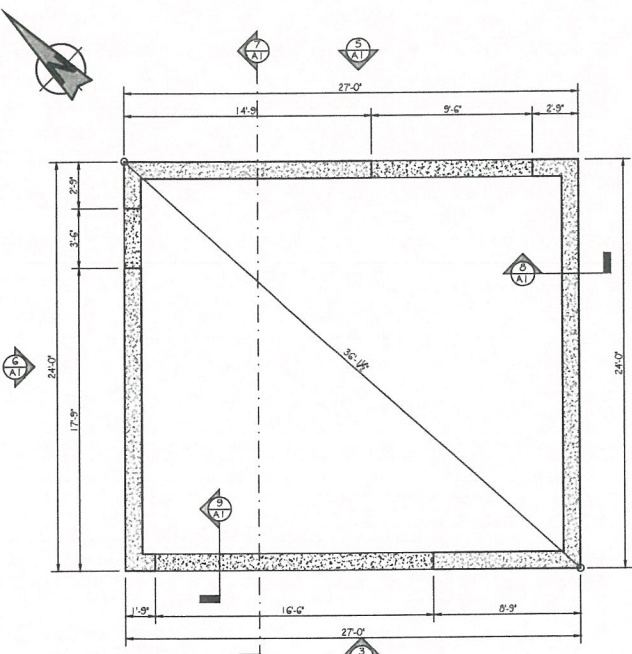

FOUNDATION PLAN
 1: A1 SCALE: 1/4" = 1'-0"

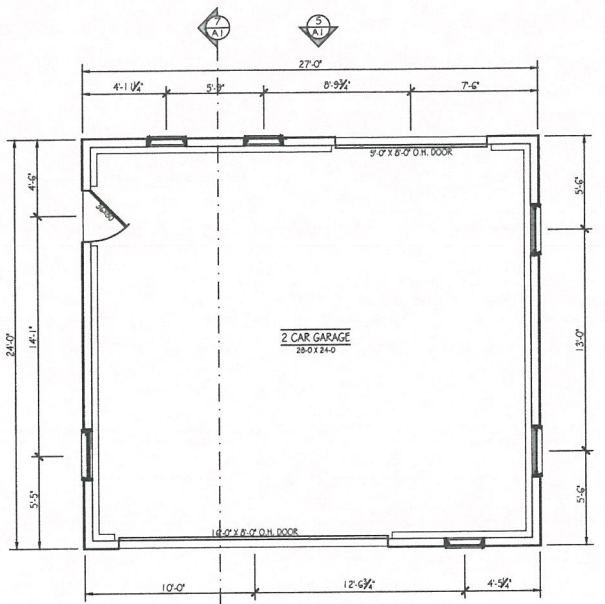

GARAGE PLAN
 2: A1 SCALE: 1/4" = 1'-0"

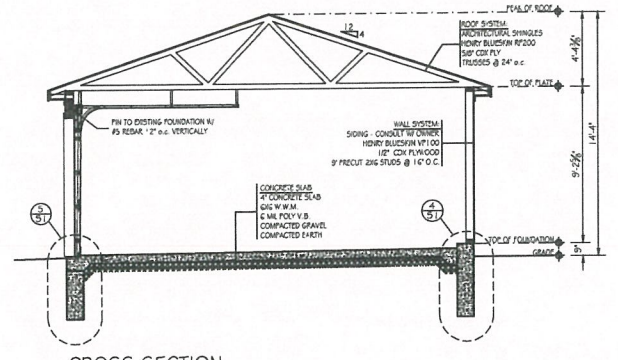

CROSS SECTION
 7: A1 SCALE: 1/4" = 1'-0"

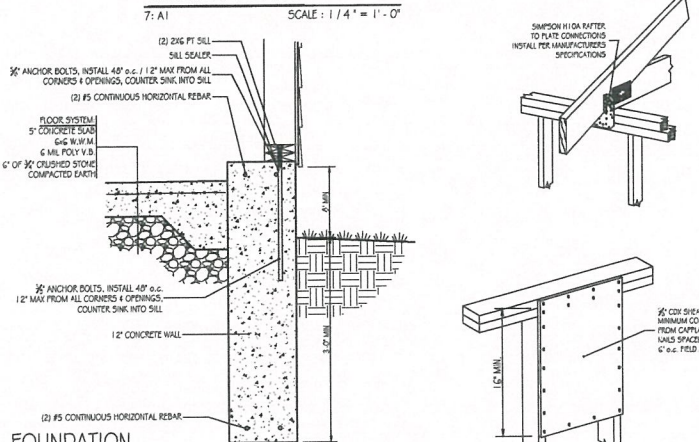

FOUNDATION
 8: A1 SCALE: 1" = 1'-0"

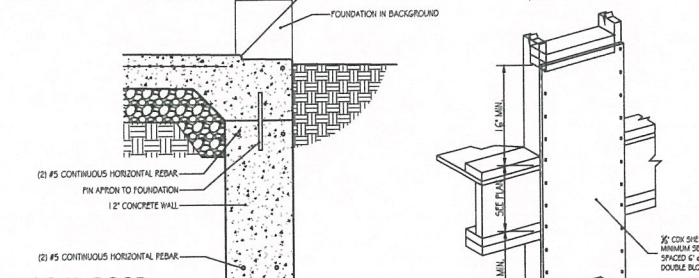

AT O.H. DOOR
 9: A1 SCALE: 1" = 1'-0"

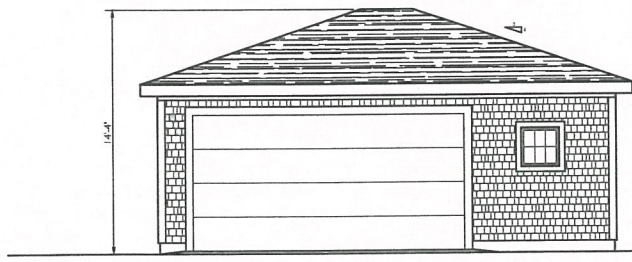

SOUTH-WEST ELEVATION
 3: A1 SCALE: 1/4" = 1'-0"

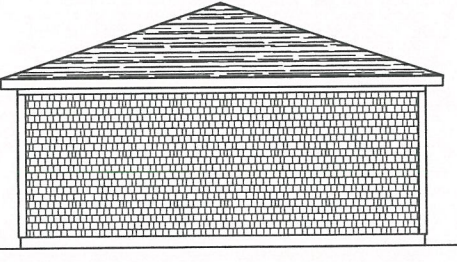

SOUTH-EAST ELEVATION
 4: A1 SCALE: 1/4" = 1'-0"

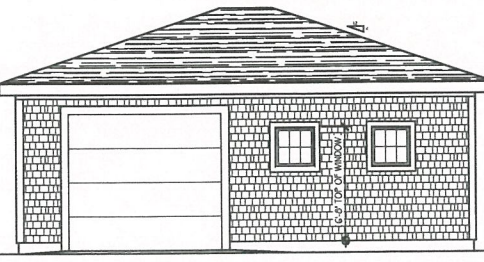

NORTH-EAST ELEVATION
 5: A1 SCALE: 1/4" = 1'-0"

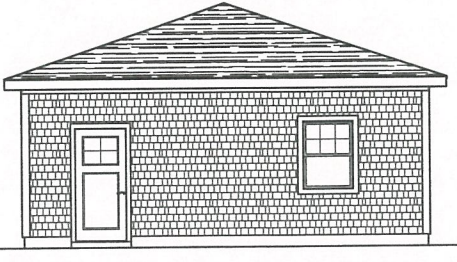

NORTH-WEST ELEVATION
 6: A1 SCALE: 1/4" = 1'-0"

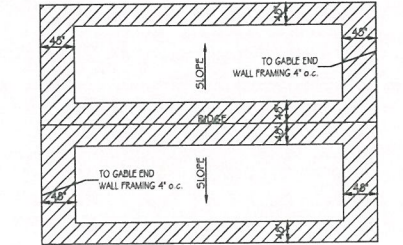

NOTE: SHEATHING MUST BE ATTACHED TO 3 RAFTERS, NO TWO (2) FOOT OR 1'6\"/>

NAILS REQUIRED B D
 REMAINDER = EDGES - 6\"/>

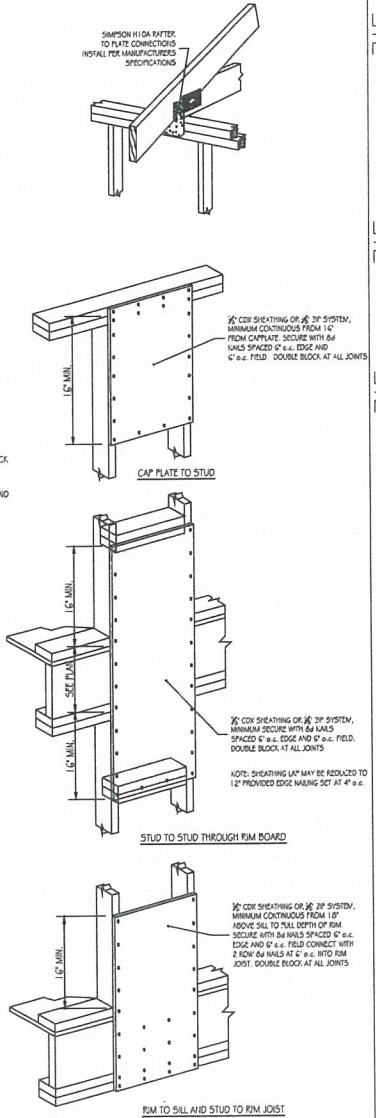

TURCHETTA
 WARWICK, RI
 72 SHAWOMET AVE

333 231
 DATE ISSUED FEBRUARY 6, 2023
 GARAGE PLANS
A1