

Patricia A. Peshka  
Purchasing Agent



Scott Avedisian  
Mayor

**City of Warwick**  
Purchasing Division  
3275 Post Road  
Warwick, Rhode Island 02886  
Tel (401) 738-2013  
Fax (401) 737-2364

The following notice is to appear on the City of Warwick's website Wednesday, March 14, 2018. The website address is <http://www.warwickri.gov/bids>.

**CITY OF WARWICK  
BIDS REQUESTED FOR**

**Bid2018-290 Police BCI Laboratory Stations**

Specifications are available in the Purchasing Division, Warwick City Hall, Monday through Friday, 8:30 AM until 4:30 PM on or after Wednesday, March 14, 2018.

Sealed bids will be received by the Purchasing Division, Warwick City Hall, 3275 Post Road, Warwick, Rhode Island 02886 up until 11:00 AM, Tuesday, April 3, 2018. The bids will be opened publicly commencing at 11:00 AM on the same day in the Warwick City Hall Council Chambers, 2<sup>nd</sup> Floor.

Awards shall be made on the basis of the lowest evaluated or responsive bid price. Please note that no bids can be accepted via email or fax.

The City of Warwick, in addition to soliciting bids in response to this RFP, may consult, consider, and make an award for any and all open bid offers for a comparable unit as sought herein at the following websites:

- RI State MPA: <http://www.purchasing.ri.gov/MPA/MPASearch.aspx>
- NASPO: <https://www.naspo.org/>
- NJPA (National Joint Powers Alliance): <https://www.njpacoop.org/cooperative-purchasing>
- MHEC (Massachusetts Higher Education Consortium): <https://www.mhec.net/>

Individuals requesting interpreter services for the hearing impaired must notify the Purchasing Division at 401-738-2013 at least 48 hours in advance of the bid opening date.

**Original Signature on File**

Patricia A. Peshka  
Purchasing Agent

**PLEASE COMPLETE THIS PAGE & SUBMIT WITH YOUR BID**

**Acknowledgement of Addendum (if applicable)**

<b>Addendum Number</b>	<b>Signature of Bidder</b>
_____	_____
_____	_____

COMPANY NAME: \_\_\_\_\_

COMPANY ADDRESS: \_\_\_\_\_

COMPANY ADDRESS: \_\_\_\_\_

BIDDER'S SIGNATURE: \_\_\_\_\_

BIDDER'S NAME (PRINT): \_\_\_\_\_

TITLE: \_\_\_\_\_ TEL. NO.: \_\_\_\_\_

EMAIL ADDRESS: \_\_\_\_\_\*

\*Please include your email address. Future bids will be emailed, unless otherwise noted.

=====

**II. AWARD AND CONTRACT:**

The CITY OF WARWICK, acting as duly authorized through its Purchasing Agent/Finance Director/Mayor (delete if inapplicable), accepts the above bid and hereby enters into a contract with the above party to pay the bid price upon completion of the project or receipt of the goods unless another payment schedule is contained in the specifications. All terms of the specifications, both substantive and procedural, are made terms of this contract.

DATE: \_\_\_\_\_

Bid2018-290

\_\_\_\_\_

Purchasing Agent

**PLEASE COMPLETE THIS PAGE & SUBMIT WITH YOUR BID**

**CERTIFICATION & WARRANT FORM\***

**This form must be completed and submitted with sealed bid.  
Failure to do so will result in automatic rejection.**

Any and all bids shall contain a certification and warrant that they comply with all relevant and pertinent statues, laws, ordinances and regulations, in particular, but not limited to Chapter 16- Conflicts of Interest, of the Code of Ordinances of the City of Warwick. Any proven violation of this warranty and representation by a bidder at the time of the bid or during the course of the contract, included, but not limited to negligent acts, either directly or indirectly through agents and/or sub-contractors, shall render the bidder's contract terminated and the bidder shall be required to reimburse the City for any and all costs incurred by the City, including reasonable attorney fees, to prosecute and/or enforce this provision.

\_\_\_\_\_  
Signature

\_\_\_\_\_  
Date

\_\_\_\_\_  
Company Name

\_\_\_\_\_  
Address

\_\_\_\_\_  
Address

**\*This form cannot be altered in any way**

**CITY OF WARWICK  
NOTICE TO BIDDERS**

**Bid2018-290 Police BCI Laboratory Stations**

If you received this document from our homepage or from a source other than the City of Warwick Purchasing Division, please check with our office prior to submitting your bid to ensure that you have a complete package. The Purchasing Division cannot be responsible to provide addenda if we do not have you on record as a plan holder.

Bids received prior to the time of the opening will be securely kept, unopened. No responsibility will be attached to an officer or person for the premature opening of a bid not properly addressed and identified. No bids shall be accepted via facsimile or email.

The opening of bids shall be in the order established by the posted agenda and the agenda shall continue uninterrupted until completion.

Once an item has been reached and any bids on that item has been opened, no other bids on that item will be accepted and any such bid shall be deemed late.

The contractor will not discriminate against any employee or applicant for employment because of physical or mental handicap for any position for which the employee or applicant is qualified and that in the event of non-compliance the City may declare the contractor in breach and take any necessary legal recourse including termination or cancellation of the contract.

A bidder filing a bid thereby certifies that no officer, agent, or employee of the City has a pecuniary interest in the bid or has participated in contract negotiations on the part of the City, that the bid is made in good faith without fraud, collusion, or connection of any kind with any other bidder for the same call for bids, and that the bidder is competing solely in his own behalf without connection with, or obligation to, any undisclosed person or firm.

All bids should be submitted with one (1) original and one (1) copy in a sealed envelope, which should read: *YOUR COMPANY NAME* plainly marked on the exterior of the envelope as well as "Bid2018-290 Police BCI Laboratory Stations."

Should you have any questions, please contact Detective Theodore Bulis, BCI Division, Warwick Police Department at 401-468-4242 or [theodore.bulis@warwickri.com](mailto:theodore.bulis@warwickri.com).

All bids should be written in ink or typed. If there is a correction with whiteout, the bidder must initial the change.

Negligence on the part of the bidder in preparing the bid confers no rights for the withdrawal of the bid after it is open.

Any deviation from the specifications must be noted in writing and attached as part of the bid proposal. The bidder shall indicate the item or part with the deviation and indicate how the bid will deviate from specifications.

The IRS Form W-9 available on [www.warwickri.gov](http://www.warwickri.gov) should be completed and submitted with the bid if the bidder falls under IRS requirements to file this form.

For a bid to be awarded to a corporation, limited liability company or other legal entity, prior to commencing work under the awarded bid, that corporation, company or legal entity may be required to provide to the Purchasing Agent a **Certificate of Good Standing** dated no more than thirty (30) days prior to the date upon which the bid approval was made.

If required, the successful bidder will provide said **Certificate of Good Standing** within ten (10) calendar days after notification or the City reserves the right to rescind said award.

Prices to be held firm one year from date of award. Term contracts may be extended for one additional term upon mutual agreement unless otherwise stated.

The contractor must carry sufficient liability insurance and agree to indemnify the city against all claims of any nature, which might arise as a result of his operations or conduct of work.

The City is exempt from the payment of the Rhode Island Sales Tax under the 1956 General Laws of the State of Rhode Island, 44-18-30, Paragraph I, as amended.

The Purchasing Agent reserves the right to reject any and all bids, to waive any minor deviations or informalities in the bids received, and to accept the bid deemed most favorable to the interest of the City.

The successful bidder must comply with all Rhode Island Laws applicable the public works projects, including, but not limited to provisions of Chapter 13 of Title 37 of the Rhode Island General Laws, pertaining to prevailing wage rates, and all other applicable local, state and federal laws.

The City reserves the right to terminate the contract or any part of the contract in the best interests of the City, upon 30-day notice to the contractor. The City shall incur no liability for materials or services not yet ordered if it terminates in the best interests of the City. If the City terminates in the interests of the City after an order for materials or services have been placed, the contractor shall be entitled to compensation upon submission of invoices and proper proof of claim, in that proportion which its services and products were satisfactorily rendered or provided, as well as expenses necessarily incurred in the performance of work up to time of termination.

No extra charges for delivery, handling or other services will be honored. All claims for damage in transit shall be the responsibility of the successful bidder. Deliveries must be made during normal working hours unless otherwise agreed upon.

All costs directly or indirectly related to the preparation of a response to this solicitation, or any presentation or communication to supplement and/or clarify any response to this solicitation which may be required or requested by the City of Warwick shall be the sole responsibility of and shall be borne by the respondent.

If the respondent is awarded a contract in accordance with this solicitation and the respondents bid or response and if the respondent fails or refuses to satisfy fully all of the respondents obligations thereunder, the City of Warwick shall be entitled to recover from the respondent any losses, damages or costs incurred by the City as a result of such failure or refusal.

The City reserves the right to award in part or full and to increase or decrease quantities in the best interest of the City.

Any quantity reference in the bid specifications are estimates only, and do not represent a commitment on the part of the City of Warwick to any level of billing activity. It is understood and agreed that the agreement shall cover the actual quantities ordered during the contract period.

The City reserves the right to rescind award for non-compliance to bid specifications.

The successful bidder must adhere to all City, State and Federal Laws, where applicable.

## **Warwick Police BCI Laboratory Stations Project**

### **Purpose:**

The purpose of this request is to replace the old Laboratory Stations with new functioning stations. The current stations are over forty years old and beyond repair. Upon completion, the new stations will enable BCI personnel to examine, analyze, and process evidence more efficiently. It will also lessen the chance of cross contamination of evidence.

### **Station #1 Lab Sink Station**

#### **FRAME**

- 1) Overall Dimensions 108" length X 26" Deep X 35" height (Bolt-Together Construction)
- 2) Frame: 1.5"/ 16 gauge tube Bolt-Together Textured Steel Gray Color
- 3) 6 (six) Leg Configuration with foot levelers

#### **2 (TWO) TOP CABINETS MOUNTED ABOVE TABLE**

- 1) 36" wide X 14" deep X 27" tall Textured Steel Gray Color
- 2) 2 (two) doors per cabinet
- 3) 1 (one) shelf per cabinet
- 4) 2 (two) sets of brackets to mount the two cabinets to/above the table
- 5) 2 (two) 24" Under Shelf LED Lights 24"L X 5"D X 1 3/4" T (one per cabinet)
- 6) 6' chord with on/off rocker switch

#### **1 (ONE) BOTTOM (UNDERMOUNT) CABINET**

- 1) 36" wide X 19" deep X 18" tall Textured Steel Gray Color
- 2) 2 (two) doors
- 3) 1 (one) shelf
- 4) To be mounted on Extreme Right Side of Station and flush to the front frame of the station

#### **BOTTOM (UNDERMOUNT) DRAWERS**

- 1) 3 (three-drawer unit) Textured Steel Gray Color
- 2) 15.5" wide X 17 1/2" deep X 18 1/2" height
- 3) Mount on Extreme Left Side of Station flush to the front frame of the station

#### **TOP STATION SURFACE**

- 1) Phenolic Surface .75" thick 26" deep Total Length 108" (two sections) Color Black
- 2) First section – 69" long with Cutouts for Sink and Faucet (see Lab Sink specs below)
- 3) Second section – 39" long
- 4) **Backsplash - .75" thick X 4" height 2(two sections) 69" and 39" Color Black**

5) 1/4" reveal left/right/front side, flush to back side

### **Lab Sink and Faucet**

- 1) 25" Wide X 22" Deep X 10.25" Height (bottom of sink to top) **Overall Dimensions**  
**"Drop In"**
- 2) Bowl Size (22"X15.75"X10.25")
- 3) 20 Gauge Stainless Steel/Satin Finish
- 4) Sound Deadening Coating
- 5) 3 1/2" Drain
- 6) Strainer
- 7) Mounting Hardware
- 8) Laboratory Gooseneck Mixing Faucet (Deck Mounted) Stainless

### **Lower Shelf**

- 1) Phenolic Surface .75" thick 22.25" deep Total Length 108" (two sections) Color Black
- 2) First Section 69" long with cutout for plumbing (see cutout specs)
- 3) Second Section 39" long

**REFER TO ATTACHED DRAWINGS BELOW FOR REFERENCE**



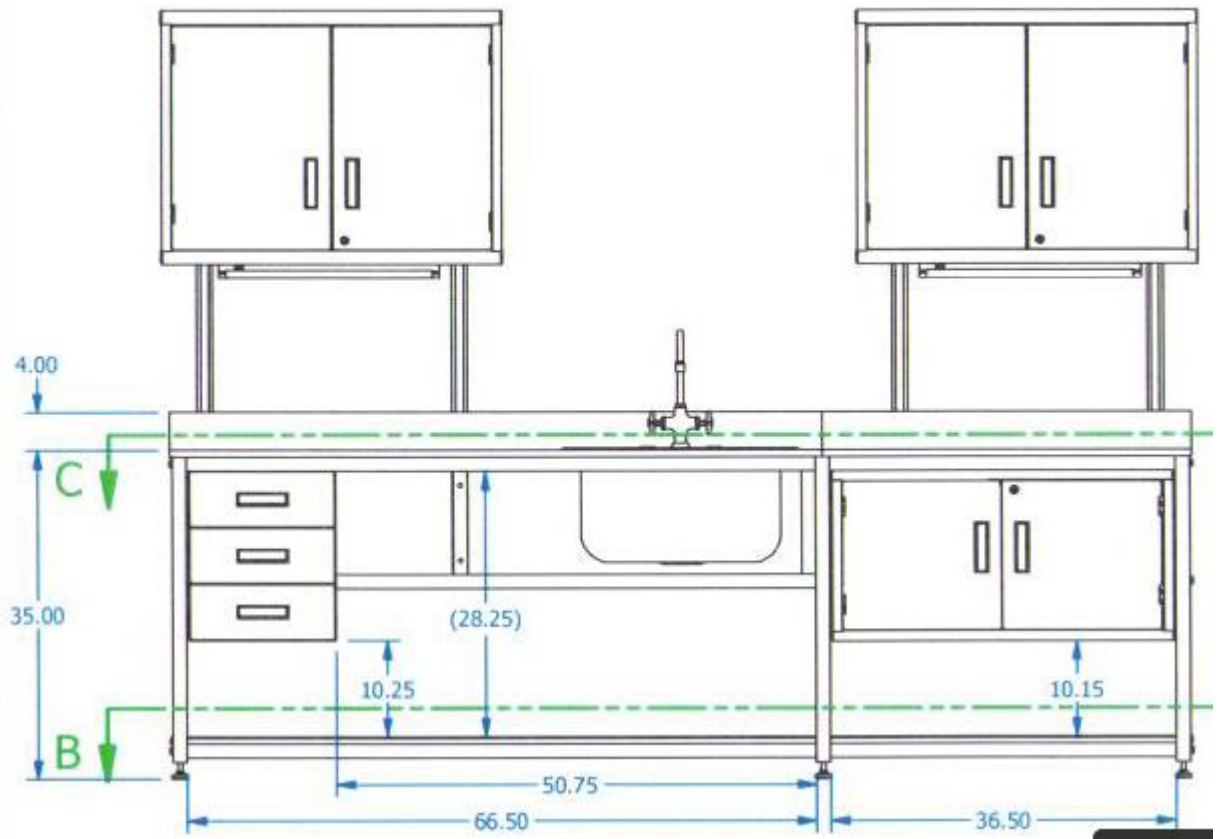
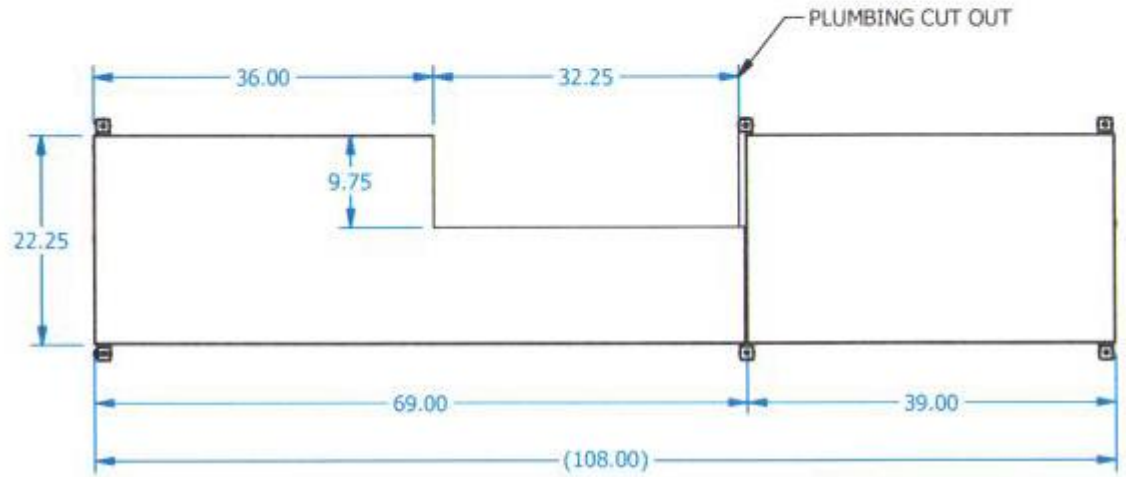
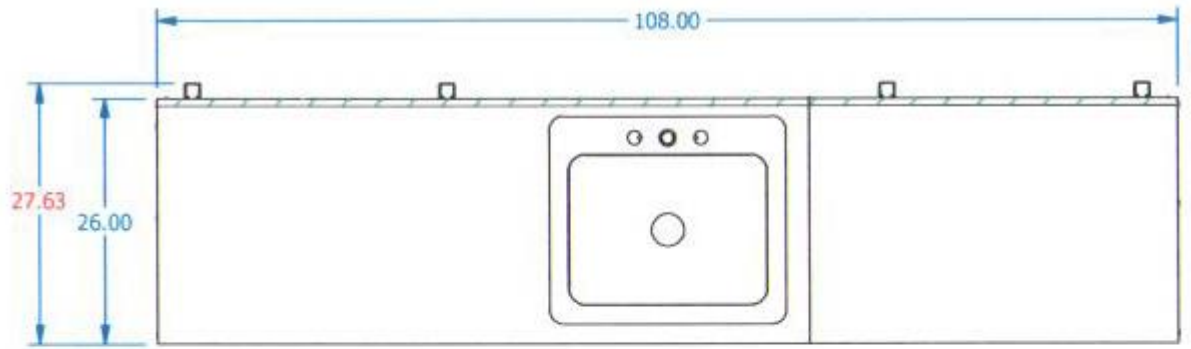

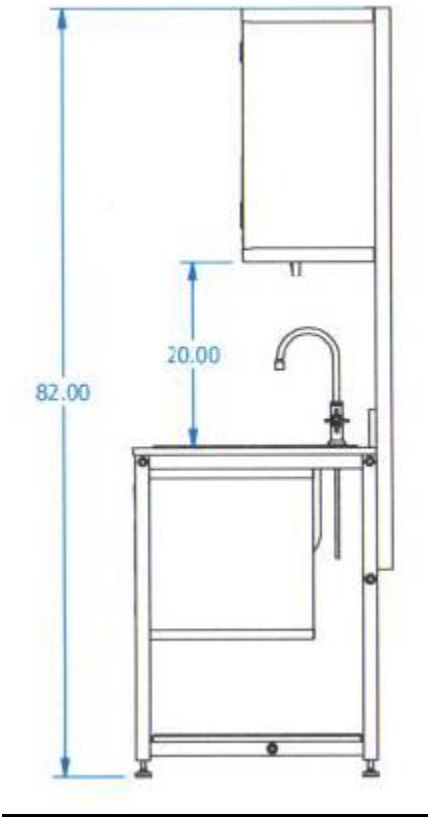

## **Station #2 Lab Work Station**

### **FRAME**

- 1) Overall Dimensions 128" length X 25" deep X 35" height (Bolt-Together Construction)
- 2) Frame 1.5" / 16 gauge tube Bolt-Together Textured Steel Gray Color
- 3) 6 (six) Leg Configuration with foot levelers
- 4) Recess Middle Leg
- 5) Frame Constructed to allow for 1" surface overhang on all sides

### **STATION SURFACE**

- 1) Phenolic Surface .75" thick 25" deep X 128" overall length Color Black
- 2) 2 (two) 64" sections
- 3) Backsplash - .75" thick X 4" height X 128" overall length Color Black
- 4) 2 (two) 64" sections

**REFER TO ATTACHED DRAWINGS BELOW FOR REFERENCE**

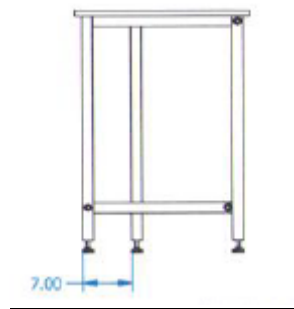
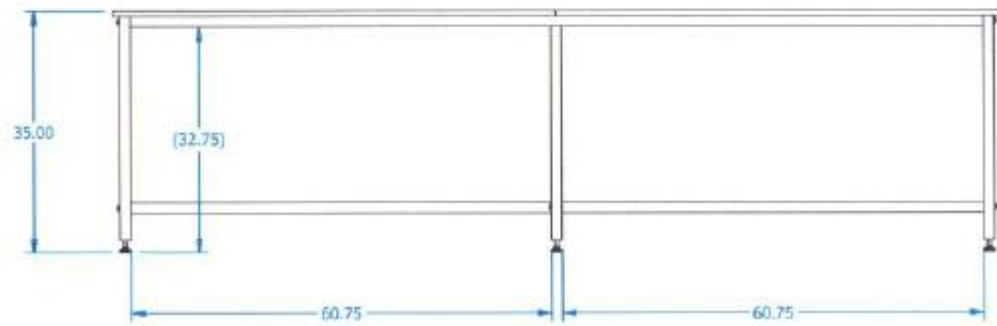

**ALL BIDS MUST INCLUDE ALL MOUNTING AND INSTALLATION HARDWARE**

**ALL BIDS MUST INCLUDE SHIPPING AND HANDLING AND INSIDE DELIVERY**

**Evaluation Criteria:**

In the event that this requires to be put out to bid the following will apply:

- 1) The lowest bid will not be used as the only single bid criteria.
- 2) The City reserves the right, at its sole discretion, to reject any and all bids.
- 3) The City may elect to award or reject any bid, solely based on inclusions, exclusions, conditions, or stipulations provided by the respondent.
- 4) The bid shall specify the duration of any warranties on products. This shall be taken into consideration in the bid.
- 5) A pre-bid conference is not required.

**Point of contact:**

Detective Theodore Bulis  
BCI Division Warwick Police Department  
401-468-4242  
theodore.bulis@warwickri.com

**PLEASE COMPLETE THIS PAGE & SUBMIT WITH YOUR BID**

**CITY OF WARWICK**

**BID AND CONTRACT FORM**

**TITLE OF SPECIFICATION:** Bid2018-290 Police BCI Laboratory Stations

**I. BID:**

WHEREAS, the CITY OF WARWICK has duly asked for bids for performance of services and/or supply of goods in accordance with the above-indicated specifications.

The person or entity below does irrevocably offer to perform the services and/or furnish the goods in accordance with the specifications, which are hereby incorporated by reference in exchange for the bid price below;

This offer shall remain open and irrevocable until the CITY OF WARWICK has accepted this bid or another bid on the specifications or abandoned the project.

The bidder agrees that acceptance below by the CITY OF WARWICK shall transform the bid into a contract. This bid and contract shall be secured by Bonds, if required by the specifications.

**Total Lump Sum:** \$ \_\_\_\_\_

**Warranty:** \_\_\_\_\_