

PROJECT MANUAL FOR

East Natick Village
Banner Sign & Canoe Access Sign Program,
Warwick, RI

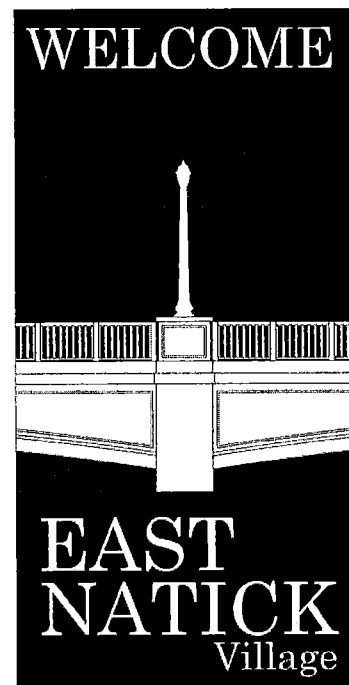

Administered By:
The City of Warwick
Office of Community Development
Kevin Sullivan, Director

Designed by:
THE GIFFORD DESIGN GROUP, Inc.
Cumberland, Rhode Island

In Association with:
Diane Soule & Assoc.
Smithfield, Rhode Island

October 2016

East Natick Village Sign Program

Table of Contents

1. Bid Form
2. Summary of Work
3. Technical Specification; 10400 – Signage
4. Federal Regulations
5. Federal Labor Standards

BID FORM

Title of Specifications:
East Natick Village Signage Program
City of Warwick, RI.

Part A:

Pursuant to and in compliance with the invitation for bids of *East Natick Village Signage Program*, and in compliance with the Contractual Documents and the Specifications relating hereto, the undersigned, unless explicitly noted, hereby offers to furnish the items necessary, proper and incidental to this work, whether incorporated on the bid or not, FOR THE TOTAL BASE BID as follows:

_____ \$ _____
(written) (figures)

The bidder shall specify his bid price in both words and figures. All words and figures shall be in ink or typed. In case of a discrepancy between the written words and those in figures, the written word shall govern.

The Bidder is required to submit a bid based upon the products having the level of quality specified in the contract documents.

Substitution Request Language:

The bidder shall identify and document cost implications involved in all substitution requests. Any and all cost savings shall be returned to the contract.

Addenda, if any, shall be issued by the owner and delivered to the undersigned by an appropriate traceable method.

The bid may be withdrawn prior to the scheduled time for opening of bids or any authorized postponement thereof.

Part B: Unit Prices

In addition to stating the Base Bid, the Bidder shall state prices for the various unit items of work listed below. The Unit Prices as quoted are for computing adjustments to the Base Bid during the course of construction, based upon extra work ordered by the Owner, or for work countermanded, reduced, or omitted by the Owner. Unit Prices are to be a complete price to be added or deducted on the basis of quantities of work involved, for each work item in place in the unit.

1. Provide and install East Natick Village banner sign:

\$ _____
Cost Each In Words Each

2. Provide and install Canoe / Kayak directional sign and post:

\$ _____
Cost Each In Words Each

ADDENDUM NO.

SIGNATURE OF BIDDER

Submitted By:

The Bidder, in compliance with the invitation for bids for *East Natick Village Signage Program*, Warwick, Rhode Island, having examined the Contract Documents and related specifications and plan, and being familiar with the site and with all the conditions surrounding the proposed construction including the availability of materials, labor and equipment, hereby proposed to construct the Project in accordance with the contract documents within the time set forth to cover all expenses incurred in performing the work required under the Contract Documents in which this proposal is a part.

The prices that are herein quoted will be the price to the Owner.

Company Name: _____ Telephone _____

Company Address: _____

Bidder's Signature: _____

Title: _____ Date _____

SECTION 01010 - SUMMARY OF WORK

PART 1 - GENERAL:

1.1 - WORK COVERED BY CONTRACT/DOCUMENTS/REQUIREMENTS

INCLUDED:

- A. The work to be done under this Contract, *East Natick Sign Program* shall occur in coordination with the East Natick Village Association, and the Warwick Office of Housing and Community Development.
- Provide and install to six East Natick Village Banner signs. These signs shall be mounted on six existing street lamps located in East Natick along East Avenue. *Provide three extra signs for future use.*
 - Provide and install six Canoe / Kayak directional signs. These signs shall be installed at locations to be determined within the Bike Path and Father Tirrochi Field, north of East Avenue. *Provide two extra signs for future use.*

1.2 - WORK SCHEDULE:

- A. The Contractor is required to submit a schedule of work sequence to the Warwick Office of Housing and Community Development.

1.3 - OBLIGATIONS OF THE CONTRACTOR:

- A. The contractor shall furnish all labor, materials, plant, supplies, equipment, tools and all other facilities necessary to the proper and complete construction of the project, as required by the Contract. Throughout the Contract, wherever it is specified that work is to be done, or labor, materials or equipment are to be furnished, it is understood to mean that the said work to be done or the labor, materials or equipment to be furnished is to be supplied or done by the Contractor at his own proper cost or expense.

1.4 - PERMITS AND LICENSES:

- A. The Contractor shall secure and pay for all local City, State, & Federal permits and licenses necessary for the execution of the work and give such notices, comply with all laws, ordinances, rules or regulations having bearing on the conduct of the work. The Contractor shall indemnify the Owner, its officers and agents against claim or liability arising from failure to comply with such rules, laws or ordinances by himself, his employees or Subcontractors. Fees shall be waived for City permits only.

1.5 - LAND AND RIGHT-OF-WAY:

- A. The Owner will provide all land and easements necessary for the construction of all permanent structures called for by the Contract. The limits of the land acquired for the permanent construction are shown on the Contract Drawings.

1.6 - RESPONSIBILITIES OF OWNER'S REPRESENTATIVE:

- A. The Owner's Representative shall be the interpreter of the requirements of the Contract Documents and the judge of the performance there under by both the Owner and Contractor. The Owner's Representative shall render interpretations necessary for the proper execution or progress of the work with reasonable promptness on written request of either the Owner or the Contractor, and shall render written decisions, within a reasonable time, on all claims, disputes and other matters in question between the Owner and the Contractor relating to the execution or progress of the work or the interpretation of the Contract Documents.
- B. Interpretations and decisions of the Owner's Representative shall be consistent with the intent of and reasonably inferable from the Contract Documents and shall be in written or graphic form. In the capacity of interpreter and judge, the Owner's Representative shall endeavor to secure faithful performance by both the Owner and the Contractor, shall not show partiality to either, and shall not be liable for the result of any interpretation or decision rendered in good faith in such capacity.
- C. The Owner's Representative shall have authority to reject work that does not conform to the Contract Documents. Whenever, in the Owner's Representative's reasonable opinion, it is necessary or advisable for the implementation of the intent of the Contract Documents, the Owner's Representative will have authority to require special inspection or testing of the work in accordance with the provisions of the Contract Documents, whether or not such work be the fabricated, installed or completed.
- D. The Owner's Representative will not control over, take charge of or, be responsible for construction means, methods, techniques, sequences or procedures, or for safety precautions and programs in connection with the work, since these are solely the Contractor's responsibility.

1.7 - CONTRACTOR'S RESPONSIBILITIES:

- A. Mutual Responsibility:
 - 1. If the Contractors or Subcontractors suffer loss or damage to their work through acts of neglect on part of General Contractor, then General Contractor agrees to satisfactorily arrange for settlement with other such Contractor or Subcontractor, if other such Contractor or Subcontractor will so settle.

2. If, however, such other Contractor or Subcontractor chooses to assert claim against Owner, on account of damage alleged to have been sustained, Owner shall notify Contractor, who shall defend, at his expense, any suit based on such claims, and, if judgment or claims against Owner shall be allowed, Contractor shall pay or satisfy such judgment or claims, and pay costs and expenses in connection with same.

B. Legal Address of the Contractor:

1. Both the address given in the Bid or Proposal submitted by the Contractor and the Contractor's office at or near the site of the work are hereby designated as places to either of which notices, letters and other communications to the Contractor shall be certified, mailed or delivered. The delivering at the above-named place, or depositing in a postpaid wrapper directed to the first-named place, in any post office box regularly maintained by the Post Office Department, or any notice, letter or other communication to the Contractor, shall be deemed sufficient service thereof upon the Contractor and the date of said service shall be the date of such delivery or mailing. The first-named address may be changed at any time by an instrument in writing, executed and acknowledged by the Contractor and delivered to the Owner's Representative. Nothing herein contained shall be deemed to preclude or render inoperative the service of any notice, letter or other communication upon the Contractor personally.

1.8 - EMPLOYEES OF THE CONTRACTOR:

A. The Contractor shall employ a competent, experienced Superintendent and Forman to represent him at the several parts of the work. These persons shall be present at all times while the work entrusted to them is in progress and shall be fully informed regarding it. The Superintendent shall be satisfactory to the Owner's Representative and shall represent and have full authority to act for the Contractor in his absence. All other persons employed on the work shall be competent and skillful persons.

1.9 - GENERAL PROTECTIVE MEASURES:

A. The Contractor shall, at his own expense, protect all work completed or partially completed under this Contract and shall be solely responsible for the care and protection of all materials covered by this Contract. Damage, loss, or injury from any cause whatsoever shall be made good by the Contractor at his own expense. The method of providing against such damage, loss or injury is left to the discretion of the Contractor. All damaged work must be replaced to the satisfaction of the Owner's Representative at no cost to the Owner.

1.10 - GENERAL SAFETY PRECAUTIONS:

- A. The Contractor shall take all necessary precautions to conduct his operations in such a manner so as to provide maximum possible safety for all employees on the work and the public as well. The Contractor shall provide suitable barricades, bridges, railings and similar protection around and over excavations and open trenches so as to insure maximum protection. All State and Federal Laws applicable to the work shall receive compliance.
- B. The Contractor shall designate a responsible member of his organization at the site whose duty shall be the prevention of accidents. This person shall be the Contractor's Superintendent unless otherwise designated in writing by the Contractor to the Owner and the Owner's Representative.

1.11 - "DIG-SAFE' DAMAGE PREVENTION SYSTEM:

- A. All Contractors or Subcontractors performing drilling, boring, augering, jetting, sheeting or pile installation, soil preloading for consolidation, demolition, excavation or like work shall, prior to commencement of these activities, contact utility companies having responsibility for underground transmission systems for information relative to locations of existing underground utilities and/or an appropriate dig safe damage prevention and notification agency.

1.12 - WEATHER CONDITIONS:

- A. No work shall be done when in the opinion of the Owner's Representative the weather is unsuitable. In no instance shall concrete, earth backfill, paving or embankment be placed upon frozen material. The Contractor shall be responsible for the protection of all completed or partially completed work as a result of extreme weather conditions. The Contractor shall make him/herself fully aware of the extremes of weather conditions in the area in regards to the depth of snowfall and the degree and length of sub-freezing temperatures during the winter season. If there is delay or interruption in the work due to weather conditions, the necessary measures must be taken to bond new work to old. Only such work as will not suffer injury to workmanship or materials will be permitted in inclement weather.

1.13 - MATERIALS AND WORKMANSHIP:

- A. All work shall be done in a neat, workmanlike manner. All materials, equipment and workmanship shall fully conform to the requirements of the Contract Documents and shall be in every respect in accordance with the best modern practice. All materials and equipment shall be new and of standard first-grade quality and design. Materials and equipment shall be assembled and erected in a neat, workmanlike manner and in proper level and alignment.

1.14 - OTHER REQUIREMENTS:

- A. Existing Structures:

1. Contractor shall be responsible for injury to existing structures.
Contractor shall be liable for damages to public or private property resulting
there from.

END OF SECTION

SECTION 10400 - SIGNAGE

PART 1 GENERAL

1.01 SECTION INCLUDES:

- A. East Natick Village Banner Signs
- B. Canoe / Kayak Launch Directional Signs

1.02 QUALITY ASSURANCE

- A. Fabrication by journeymen sign manufacturers.

1.03 SUBMITTALS

- A. Proofs of each sign.
- B. Color chips.
- C. Material product samples.
- D. Bracket and Hardware shop drawings

1.04 SIGN GRAPHIC

- A. A digital graphic file will be provided for the 18" by 36" East Natick banner sign, which will have the following appearance:

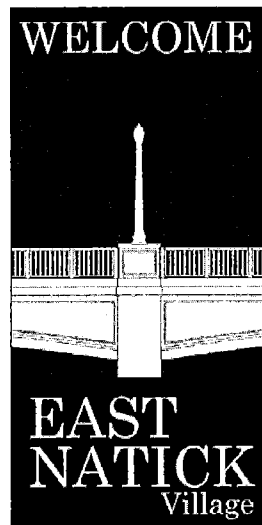

- B. A digital graphic file will be provided for the 12” by 12” canoe / kayak directional sign, which will have the following appearance:

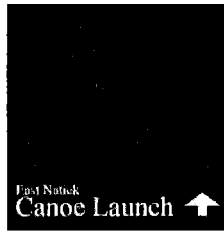

Please note that the directional arrow will change on each canoe / kayak directional sign, dependant on the location of the sign. This arrow may be a self-adhesive material.

PART 2 PRODUCTS

2.01 SIGN PANEL

- A. Provide nine (9) East Natick banner signs. Three of these signs will not be installed, and will be placed in storage.
- B. Provide eight (8) Canoe / Kayak launch signs. Two of these signs will not be installed, and will be placed in storage, with the adhesive arrow *not adhered*.
- C. Signs shall be constructed of high definition color printing on 6mm thick layered sign product comprised of two-sided aluminum skins bonded to a solid polyethylene core (MaxMetal, or equal).

2.02 MOUNTING HARDWARE & SUPPORTS

- A. Metal Fasteners and Screws
1. All metal fasteners shall be heavy-duty stainless steel. All accessible fasteners shall be tamper-resistant type fasteners.
- B. Banner Mounting Brackets
1. Provide nine (9) pairs of cast aluminum banner arms and nine (9) pairs of cast aluminum clamp-on mounts, as manufactured by Antique Street Lamps (or approved equal). Color: black. Cut sheets are attached.
 2. Provide nine (9) sets of four-corner brackets appropriate for mounting rigid sign panels to the banner arms. Color: black.

C. Canoe Launch Sign Posts

1. Provide six (6) pressure treated 4x4 wood mounting posts, six feet in length for installation of the Canoe / Kayak signs. Pressure treatment shall be suitable for ground contact. Corners to be rounded. Provide 30 degree sloped top cut at the top of the post.

PART 3 EXECUTION

3.01 GENERAL REQUIREMENTS

- A. Contractor to provide proof of sign design based on Owner's Representative layout instructions.
- B. Contractor shall install six (6) signs banner signs, and deliver three (3) extra signs and mounting brackets with brackets and hardware to the City Office of Housing & Community Development.
- C. Contractor shall install six (6) canoe / kayak signs, and deliver two (2) extra signs, two (2) adhesive arrows and mounting hardware to the City Office of Housing & Community Development.
- D. Contractor shall walk the site with Owner's representative to identify final sign locations prior to installation.
- E. Fabrication and installation to meet highest standards of quality for this work. Set signs square and level. Set brackets perpendicular to the existing light posts. Set posts plumb.
- F. No patching or field cutting shall be performed. Products may be rejected by the Owner if not properly fabricated to fit the conditions. Replacement products shall be furnished and installed at no additional cost to the Owner.
- G. Use cleaning methods and materials to leave the work neat and free of blemishes, stains or scratches.
- H. Pressure treated mounting posts for the Canoe / Kayak directional signs shall be set plumb, with 3 feet set in the ground, and 3 feet above grade. Provide 30 degree sloped top cut at the top of the post.

END OF SECTION

(Sign Bracket Cut Sheets Follow)

Banner Arms Cast Aluminum

SPECIFICATIONS

DESCRIPTION

The banner arms shall consist of a round, extruded aluminum pipe and a removable cast aluminum end cap. Bottom eyebolts and banner arms with breakaway couplings, are optional and recommended because of the wind load from the banner.

CONSTRUCTION

The banner arm shall be welded to a mounting plate or a post clamp. All welding shall be per ANSI/AWS D1.2-90. All welders shall be certified per ANSI/AWS D1.2-90 Section 5.

MATERIALS

The end caps shall be, copper free, cast aluminum produced from certified ASTM 356.1 Ingot per ASTM B-179-95a or ASTM B26-95. The banner arm, mounting plate and post clamp shall be aluminum, ASTM 6061 alloy, heat treated to a T6 temper. All hardware shall be stainless steel.

INSTALLATION

The bolt-on banner arm shall bolt to a mounting channel provided on the side of the post with four stainless steel screws. Eyebolts shall screw into the post or clamp on. All clamp-on mountings shall clamp around the post, secured with four 3/8" hex head bolts. (Post dia. at mounting point must be specified.) A minimum mounting height of 10 feet is recommended for the bottom banner arm. (Arms are not designed for pedestrian interference.) (For information on specifying orientation and mounting heights see "Orientation Guide" in the back of the Accessories section of catalog.) (Banners to be provided by others.)

DIMENSIONS

The banner arms shall be available in 1.05", 1.32", 1.66" or 1.9" O.D. and to the specified length.

For finish specifications and color options see "Finish" section in catalog.

ANTIQUÉ Street Lamps

2011-B W. Rundberg Ln. • Austin, TX 78758
Ph (512) 977-8444 • Fax (512) 977-9622

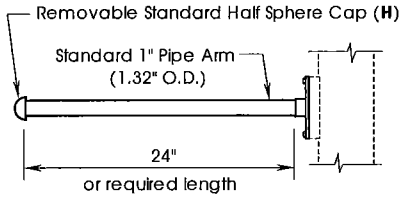

BAB 24H4
(banner arm, bolt-on,
24" lg., 1"Ø)

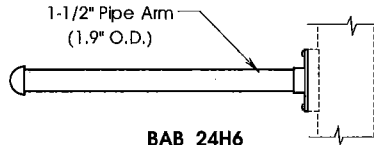

BAB 24H6
(banner arm, bolt-on,
24" lg., 1.5"Ø)

Other size Banner Arms Available:

BAB XXH3
(banner arm, XX" lg.,
.75" pipe (1.05" O.D.))

BAB XXH5
(banner arm, XX" lg.,
1.25" pipe (1.66" O.D.))

OTHER MOUNTING OPTIONS

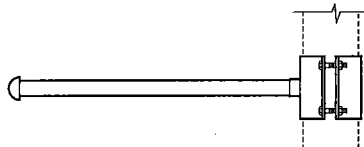

BAC19 BACDxx 24H4
(1 banner arm with clamp-on mounting,
xx = clamp dia., 24" lg. x 1"Ø arm)

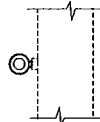

EBB
(eyebolt mounted
to post for securing
banner bottom)

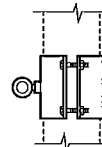

EBC19 EBCDxx
(eyebolt with clamp
on mounting for secur-
ing banner bottom)

OTHER OPTIONS

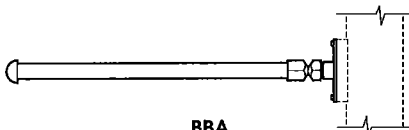

BBA
(breakaway option)

End Caps

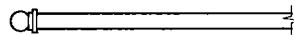

B
(Ball end cap)

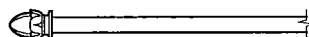

A
(Acorn end cap)

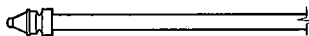

R
(Raleigh end cap)

Decorative Options



BAEB
(two eyebolts on arm)

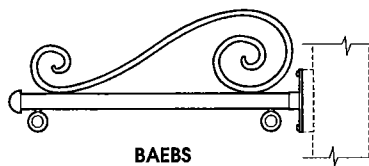

BAEBS
(decorative scroll & two
eyebolts on arm)

NOTE: Banner arms can add substantial wind loading to the post you select. Please coordinate the correct post size and style with the factory.

Banner Arms Cast Aluminum

MOUNTING DETAILS

Bolt-On Mounting

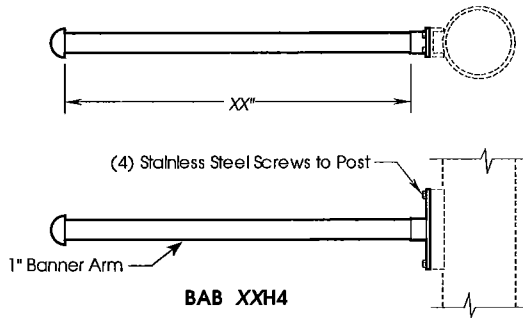

Clamp On Mounting

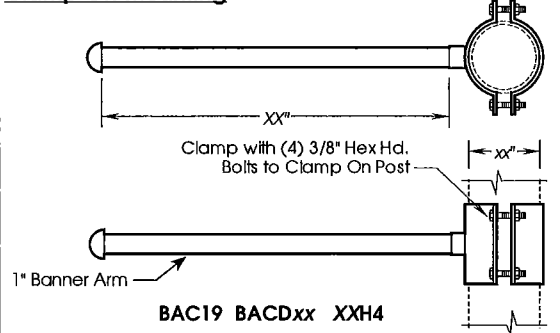

SUGGESTED BANNER ARM USAGE

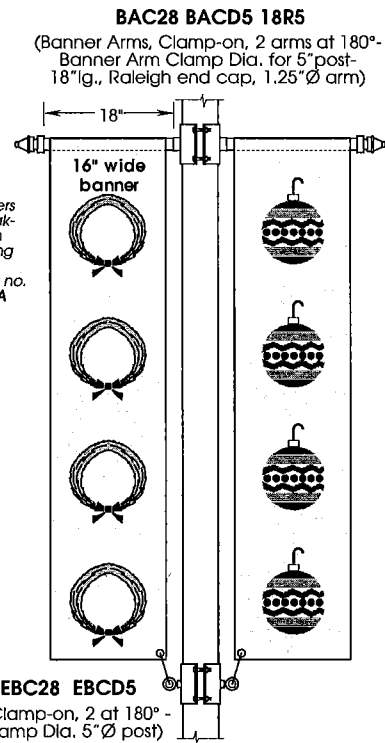
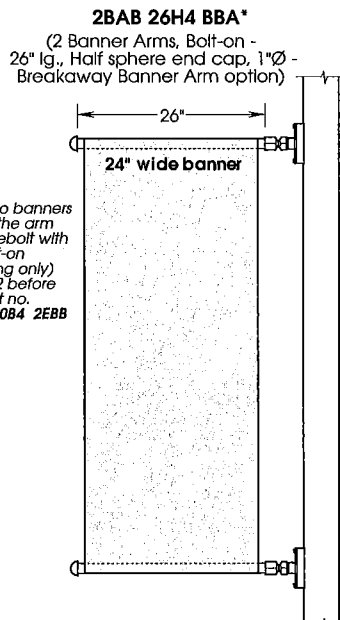
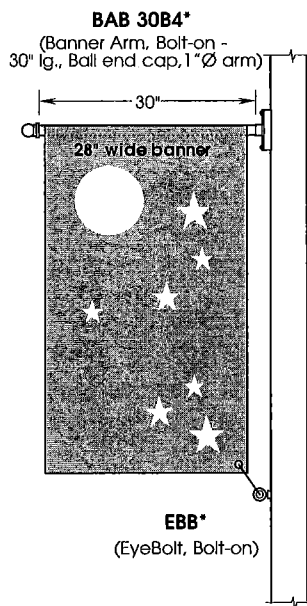

NOTE:
* For information on specifying orientation and mounting heights see **Orientation Guide** in the back of the Accessories section in the catalog. A minimum mounting height of 10' is recommended for the bottom banner arm.
• Banners not furnished by Antique Street Lamps.

ORDERING INFORMATION

Choose the **boldface** catalog nomenclature that best suits your needs and write it on the appropriate line.

Example: **BAC19 BACD4 18H4 BAEB EBC19 EBCD4 ANBK**

Banner Arms (type, qty)		BA Clamp Dia. ^{2,3}	Length ¹	End Cap	Options	Eyebolts (type, qty)	EB Clamp Dia. ^{2,3}
Bolt-ons^{1,2}		<i>(clamp-ons only)</i>				Bolt-ons^{1,2}	<i>(clamp-ons only)</i>
BAB 1 Banner Arm		BACD3 3" Ø	12	H Half Sphere	BBA Breakaway Arm	EBB 1 Eyebolt	EBCD3 3" Ø
2BAB 2 Banner Arms		BACD3-1/2 3-1/2" Ø	18	B Ball Cap	BAEB Arm w/eyebolts	2EBB 2 Eyebolt	EBCD3-1/2 3-1/2" Ø
3BAB 3 Banner Arms		BACD4 4" Ø	19	A Acom Cap	BAEBS Arm w/eyebolts and Scroll	3EBB 3 Eyebolt	EBCD4 4" Ø
4BAB 4 Banner Arms		BACD4-1/2 4-1/2" Ø	20	R Raleigh Cap		4EBB 4 Eyebolt	EBCD4-1/2 4-1/2" Ø
6BAB 6 Banner Arms		BACD5 5" Ø	24				EBCD5 5" Ø
8BAB 8 Banner Arms		BACD5-1/2 5-1/2" Ø	25				EBCD5-1/2 5-1/2" Ø
Clamp-ons		BACD6 6" Ø	26			Clamp-ons	EBCD6 6" Ø
<i>one set</i>	<i>two sets</i>	BACD6-1/2 6-1/2" Ø	28	Arm dia.		<i>one set</i>	EBCD6-1/2 6-1/2" Ø
BAC19 1 Arm	2BAC19	BACD7 7" Ø	30	3 3/4"Ø		EBC19 1 Eyebolt	EBCD7 7" Ø
BAC28 2 Arms @ 180°	2BAC28	BACD7-1/2 7-1/2" Ø	36	4 1"Ø		EBC28 2 bolts @ 180°	EBCD7-1/2 7-1/2" Ø
BAC29 2 Arms @ 90°	2BAC29	BACDTBS Ø to be specified		5 1-1/4"Ø		EBC29 2 bolts @ 90°	EBCDTBS Ø to be specified
BAC39 3 Arms @ 90°	2BAC39			6 1-1/2"Ø		EBC32 3 bolts @ 120°	
BAC49 4 Arms @ 90°	2BAC49					EBC39 3 bolts @ 90°	
						EBC49 4 bolts @ 90°	
						2EBC19	
						2EBC28	
						2EBC29	
						2EBC32	
						2EBC39	
						2EBC49	
							Finish*
							ANBK Black
							ANDB Dark Bronze
							ANDG Dark Green
							ANVG Verde Green
							ANPP Prime Painted
							CM Custom Match
							CS Custom Select RAL colors

NOTES:
1. For information on specifying orientation and mounting heights see the **Orientation Guide** in the back of the Accessories section in the catalog.
2. A minimum mounting height of 10' is recommended for the bottom banner arm.
3. For clamp dia. take post dia. and round up to the nearest 1/2".
4. For finish and color options see **Finish** section in catalog.

ANTIQUE Street Lamps

2011-B W. Rundberg Ln. • Austin, TX 78758 • Ph (512) 977-8444

V. FEDERAL REGULATIONS

EXCERPT FROM TITLE 24-HOUSING AND URBAN DEVELOPMENT
PART 135-EMPLOYMENT OPPORTUNITIES FOR BUSINESS AND LOWER INCOME
PERSONS IN CONNECTION WITH ASSISTED PROJECTS

(m) "Section 3 covered project" means any nonexempt project assisted by any program administered by the Secretary in which loans, grants, subsidies, or other financial assistance are provided in aid of housing, urban planning, development, redevelopment, or renewal, public or community facilities, and new community development (except where the financial assistance available under such program is solely in the form of insurance or guaranty). Projects, contracts, and subcontracts, connected with programs administered by the Secretary under section 235 and 236 of the National Housing Act as well as any Public Housing program and which do not exceed \$500,000 in estimated cost are exempted from the requirements of this part, as is any subcontract of \$50,000 or under on such projects or contracts in excess of \$500,000.

Section 135.20 Assurance of compliance with regulations.

(a) Every contract or agreement for a grant, loan, subsidy, or other direct financial assistance in aid of housing, urban planning, development, redevelopment, or renewal, public or community facilities, and new community development, entered into by the Department of Housing and Urban Development with respect to a section 3 covered project shall contain provisions requiring the applicant or recipient to carry out the provisions of section 3, the regulations set forth in this part, and any applicable rules and orders of the Department issued there under prior to approval of its application for assistance for a section 3 covered project.

(b) Every applicant, recipient, contracting party, contractor, and subcontractor shall incorporate, or cause to be incorporated, in all contracts for work in connection with a section 3 covered project, the following clause (referred to as a section 3 clause):

A. The work to be performed under this contract is on a project assisted under a program providing direct Federal financial assistance from the Department of Housing and Urban Development and is subject to the requirements of section 3 of the Housing and Urban Development Act of 1968, as amended, 12 U.S.C. 1701u. Section 3 requires that to the greatest extent feasible opportunities for training and employment be given lower income residents of the project area and contracts for work in connection with the project be awarded to business concerns which are located in, or owned in substantial part by persons residing in the area of the project.

B. The parties to this contract will comply with the provisions of said section 3 and the regulations issued pursuant thereto by the Secretary of Housing and Urban Development, and all applicable rules and orders of the Department issued there under prior to the execution of this contract. The parties to this contract certify and agree that they are under no contractual or other disability which would prevent them from complying with these requirements.

C. The contractor will send to each labor organization or representative of workers with which he has a collective bargaining agreement or other contract or understanding, if any, a notice advising the said labor organization or workers' representative of his commitments under this section 3 clause and shall post copies of the notice in conspicuous places available to employees and applicants for employment or training.

D. The contractor will include this section 3 clause in every subcontract for work in connection with the project and will, at the direction of the applicant for or recipient of Federal financial assistance, take appropriate action pursuant to the subcontract upon a finding that the subcontractor is in violation of regulations issued by the Secretary of Housing and Urban Development. The contractor will not subcontract with any subcontractor where it has notice or knowledge that the latter has been found in violation of regulations and will not let any subcontract unless the subcontractor has first provided it with a preliminary statement of ability to comply with the requirements of these regulations.

E. Compliance with the provisions of section 3, the regulations and all applicable rules and orders of the Department issued there under prior to the execution of the contract, shall be a condition of the Federal financial assistance provided to the project, binding upon the applicant or recipient for such assistance, its successors and assigns. Failure to fulfill these requirements shall subject the applicant or recipient, its contractors and subcontractors, its successors, and assigns to those sanctions specified by the grant or loan agreement or contract through which Federal assistance is provided, and to such sanctions as are specified.

Subpart C-Utilization of Lower Income Area Residents as Employees.

Section 135.55 General.

Each applicant, recipient, contractor or subcontractor undertaking work in connection with a section 3 covered project shall fulfill his obligation to utilize lower income project area residents as employees to the greatest extent feasible by:

(a) Identifying the number of positions in the various occupational categories including skilled, semiskilled and unskilled labor, needed to perform each phase of the section 3 covered project;

(b) Identifying, of the positions identified in paragraph (a) of this section, the number of positions in the various occupational categories which are currently occupied by regular, permanent employees;

(c) Identifying, of the positions identified in paragraph (a) of this section, the number of positions in the various occupational categories which are not currently occupied by regular, permanent employees;

(d) Establishing, of the positions identified in paragraph (a) of this section, a goal which is consistent with the purpose of this subpart within each occupational category of the number of positions to be filled by lower income residents of the section 3 covered project area; and

(e) Making a good faith effort to fill all of the positions identified in paragraph (d) of this section with lower income project area residents.

Section 135.60 Good faith effort.

(a) Each applicant, recipient, contractor, or subcontractor seeking to establish that a good faith effort as required by paragraph (e) of section 135.55 has been made to fill all employment positions identified in paragraph (d) of Section 135.55 with lower income project area residents shall, as a minimum, set forth evidence acceptable to the Secretary that it has:

(1) Ascertained from the Department's Regional Administrator, Area Office Director, or FHA Insuring Office Director having jurisdiction over the section 3 covered project the boundaries of the section 3 covered project area; and

(2) Attempted to recruit from the appropriate areas the necessary number of lower income residents through: Local advertising media, signs placed at the proposed site for the project, and community organizations and public or private institutions operating within or serving the project area such as Project Area Committees (PAC) in urban renewal areas, Model Cities citizen advisory boards, Service Employment and Redevelopment (SER), Opportunities Industrialization Center (OIC), Urban League, Concentrated Employment Program, or the U.S. Employment Service.

(b) Any applicant, recipient, contractor or subcontractor which fills vacant Section 135.55 (d) employment positions in its organization immediately prior to undertaking work pursuant to a section 3 covered contract shall set forth evidence acceptable to the Secretary that its actions were not an attempt to circumvent these regulations.

(c) When lower income resident workers apply, either on their own initiative or on referral from any source, the recipient, contractor, or subcontractor shall determine the qualifications of such persons and shall employ such persons if their qualifications are satisfactory and the contractor has openings. If the recipient, contractor, or subcontractor is unable to employ the workers, such persons shall be listed for the first available opening.

Subpart D-Utilization of Business Located in or Owned in Substantial Part by Persons Residing in the Area.

Section 135.65 General.

Each applicant, recipient, contractor or subcontractor undertaking work on a section 3 covered project shall assure that to the greatest extent feasible, contracts for work to be performed in connection with the project are awarded to business concerns located within the section 3 covered project area or business concerns owned in substantial part by persons residing in the section 3 covered area. The Department, in consultation with the Small Business Administration will establish for the section 3 covered project area a registry of business concerns which meet the definition contained in section 135.5 (b) and (c). Each applicant, recipient, contractor, or subcontractor undertaking work in connection with a section 3 covered project shall fulfill his obligations to utilize business concerns located within or owned in substantial part by persons residing in the section 3 covered project area by developing and implementing an affirmative action plan.

SECTION 3 REQUIREMENTS

1. Policy

The Department of Housing and Urban Development (HUD) requires that any contract let under the Community Development Block Grant Program be in accordance with the regulations of 24 CFR 135 and Section 3 of the Housing and Urban Development Act of 1968, 12 U.S.C. 1701 u. These regulations state that preference must be given in employment and training opportunities and in contracts to be let to lower-income project area residents and eligible Section 3 businesses, respectively.

2. Section 3 Business

An "eligible Section 3 business" means any business concern which meets one of the following standards:

(a) The business is located in the project area and qualifies as a small business using SBA standards.

(b) The business is located outside the project area and qualifies as small using SBA standards. In addition, at least 51 percent of the business is owned by persons who reside in the project area and who qualify under SBA standards as socially or economically disadvantaged.

SBA standards for qualification as a small business are as follows:

(a) Wholesale - annual receipts no more than \$5 million to \$15 million depending on the industry.

(b) Retail or Service - annual receipts no more than \$1 million to \$5 million depending on industry.

(c) Construction - annual receipts not more than \$5 million averaged over the last 3 years.

(d) Manufacturing - no more than 250 to 1,500 employees, depending on the industry.

Precise criteria may be found in Part 121, Title 13 of the Code of Federal Regulations.

Qualifications as an "economically or socially disadvantaged Person" may be achieved by meeting any one of the following SBA standards:

(a) Member of a minority group which has been deprived of access to normal economic financial resources.

(b) An identifiable physically handicapped person, where the handicap severely limits that person's ability to obtain financial assistance to enter or to improve a business.

(c) Any person whose residence and business are located in an area where the local banking community is unable or unwilling to provide small business financing.

(d) Any honorable discharged Vietnam-era veteran (since August 5, 1964).

3. Bidding Procedure

All successful bidders must submit prior to contract award their Section 3 plan. This plan will contain a preliminary Statement of Workforce Needs (attachment A1, 2) outlining goal for utilization of lower-income project area residents, and an Affirmative Action Plan (Attachment B) for Section 3 Businesses outlining goals for award of subcontracts to eligible Section 3 businesses. This plan will be evaluated for its consistency with the overall goals of the municipality, and whether the affirmative action proposed by the contractor will achieve the goal. Failure to submit an acceptable Section 3 Plan shall result in bid rejection.

Instructions

The Contractor shall submit a preliminary statement of work force needs (skilled, semi-skilled, unskilled labor and trainees by category) where known with the bid (Attachment A2). As evidence of compliance with the regulations in 24 CFR 135, the contractor shall provide the City with the following information prior to the awarding of the contract. (Attachments A1, A2 & B).

1. A list of all positions required for the completion of the contract.
2. A list of all positions which are presently vacant or which will be new positions which will become available under the Contract.
3. A list of the maximum number of training positions which may be utilized under the program.
4. A list of training positions which are currently vacant or which are new positions to become available under the Contract.
5. Goals for filling available positions for employment and training with lower income Warwick residents and the methods to be used to recruit lower income Warwick residents pursuant to the regulations in 24 CFR 135, Subparts B and C.
6. A list of all subcontracts and/or work to be let out in connection with the project including the type of businesses to be used and the dollar value of all work or contracts.
7. A goal and affirmative action plan for utilizing Warwick businesses pursuant to the regulations in 24 CFR 135, Subpart D.

8. Compliance Reports

The contractor and all subcontractors shall be monitored through compliance reports submitted monthly to the Chief Executive Officer of the municipality, or to his designee: **Kevin Sullivan**. Failure to make a good faith effort to implement this Section 3 Plan shall result in termination for cause of the contract.

9. Certification as a Lower-Income Person

As you will note from the example Section 3 Plan, you are required to maintain a list of qualified lower-income persons who apply for work with your business as a result of award of this contract. It is your responsibility to determine if such an applicant for employment does in fact qualify as a lower-income person residing in the project area. This requirement can be satisfied by using an application and certification form which will be provided to the applicant when he/she applies.

Attachment A1

City of Warwick
Community Development Program
Section 3 Compliance

1. Work force needs - see attached
2. Vacant and/or new positions to be available.
3. Training positions for completion of contract.
4. Training positions available.
5. Goal for filling available positions with lower-income Warwick residents.
6. Subcontractors, suppliers and value.
7. Compliance requirements. Advertisement in metropolitan and local newspaper. Job listings with Department of Employment Security.
8. Affirmative action plan for utilizing Warwick Business - see attachment B.

Attachment A2

Preliminary Statement of Work Force Needs

List the number of employees in each classification by position category:

SKILLED

SEMI-SKILLED

UNSKILLED

TRAINEES

Contractor's Name and Address: _____

Contractor's Signature

Attachment B

City of Warwick
Community Development Program

Affirmative Action Plan
for
Utilizing Local Businesses

This plan sets forth the procedures by which the City of Warwick will assure that to the greatest extent feasible contracts for work in connection with the City's Community Development Program will be awarded to business concerns which are located in or owned in substantial part by persons residing in the City of Warwick. These procedures are set forth in compliance with the rules and regulations in Part 135 of Title 24 of the Code of Federal Regulations entitled "Employment Opportunities for Businesses and Lower Income Persons in Connection with Assisted Projects" published on August 3, 1973. It is the intent of this plan that the City and its contractors follow these procedures in awarding any work financed under the City's Community Development Program.

1. At the beginning of each Community Development Program Year the City will prepare and make available to the public a list of contracts expected to be awarded and a description of the professional category or classification of each type of service or supplied to be provided in order to carry out the Community Development Program.
2. The City will prepare a list of businesses known to be located within the City which appear to be eligible to provide the services, supplies or construction work in order to determine the availability of local businesses for each contract listed in compliance with No. 1 above.
3. The City and its contractors shall, where feasible, award all contracts to local businesses. Reasons for awarding contracts to other firms shall be documented. Sufficient reason for awarding contracts to firms outside the City shall include non-competitive bids or the unavailability of local firms or individuals who can provide the services or supplies required.
4. The City and its contractors shall comply with the following procedures in order to assure that local businesses are afforded the opportunity to contract with the City or other contractors under the Community Development Program:
 - (a) The Community Development Program's Affirmative Action Plan for Utilizing Local Businesses shall be inserted into all bid documents for work funded under the Community Development Program.
 - (b) Local businesses for the purpose of complying with these procedures shall be those located within the entire City of Warwick or owned in substantial part by residents of Warwick.

(c) All contractors and subcontractors shall certify their intent to comply with the objectives and procedures of this plan prior to signing a contract with the City. All contracts and subcontracts will be awarded in compliance with this plan and must be approved by the City of Warwick in writing.

(d) Opportunities or contracts under the Community Development Program shall be advertised in the metropolitan and local newspapers. A notice of the pending contract shall be posted on the site, where applicable, or in the City Hall. Notification of pending contractual opportunities shall be sent to the City's Purchasing Agent.

(e) All contracts for more than \$1,000 shall be awarded on the basis of competitive bids in conformance with City and Federal procedures.

(f) All bids or proposals must be accompanied by a list of all positions for employment or training by occupational category and a list of all subcontracts necessary to fulfill the contract. In addition, each bidder shall submit with the bid, a certification adopting this plan for utilizing local businesses.

City of Warwick
Community Development Program

Affirmative Action Plan
for
Utilizing Local Businesses

I, _____, certify that I have
(Contractor)

read and understand the Community Development Program's Affirmative Action Plan for Utilizing Local Businesses and further certify that all work let out under this contract shall be in conformance with its objectives and procedures. I understand that I am certifying that to the greatest extent feasible all sub-contracts or other work let out under this contract will be awarded to businesses located in Warwick or businesses which are owned in substantial part by residents of Warwick.

Witness: _____ By: _____

(Contractor)

Title: _____

Business Address: _____

Date: _____

Attachment A

Affirmative Action Requirements
for
Rhode Island

Notice of Requirement for Affirmative Action to Ensure Equal Employment Opportunity
(Executive Order 11246)

1. The Officer's or Bidder's attention is called to the "Equal Opportunity Clause" and the "Standard Federal Equal Employment Opportunity Construction Contract Specifications" set forth herein.
2. The goals and timetables for minority and female participation, expressed percentage terms for the contractor's work force in each trade on all construction work in the covered area are as follows:

Female: 4-1-78 to 3-31-79 3.1%
4-1-79 to 3-31-80 5.0%
4-1-80 to 3-31-81 6.9%

Minorities: ALL TRADES 3.0%

These goals are applicable to all contractor's construction work (whether or not it is Federal or federally assisted) performed in the covered area.

The Contractor's compliance with the Executive Order and the regulations in 41 CFR Part 60-4 shall be based on its implementation of the Equal Opportunity Clause, specific affirmative action obligations required by the specifications set forth in 41 CFR-4.3(a) and its efforts to meet the goals established for the geographical area where the contract resulting from this solicitation is to be performed. The hours of minority and female employment and training must be substantially uniform throughout the length of the contract, and in each trade, and the contractor shall make a good faith effort to employ minorities and women evenly on each of its projects. The transfer of minority or female employees or trainees from Contractor to Contractor or project to project for the sole purpose of meeting the Contractor's goals shall be a violation of the contract, the Executive Order, and the regulations in 41 CFR Part 60-4. Compliance with the goals will be measured against the total work hours performed.

3. The Contractor shall provide written notification to the Director of the Office of Federal Contract Compliance Programs within 10 working days of award of any other construction subcontract in excess of \$10,000 at any tier for construction work under the contract resulting from this solicitation. The notification shall list the name, address and telephone number of the subcontractor; employer identification number, estimated dollar amount of the subcontract; estimated starting and completion dates of the subcontract; and the geographical area in which the contract is to be performed.

4. As used in this Notice, and in the contract resulting from this solicitation, the "covered area" is:

Female: Nation-wide

Minorities: State-wide

The contractor shall take specific affirmative actions to ensure equal employment opportunity. The evaluation of the Contractor's compliance with these specifications shall be based upon its effort to achieve maximum results from its actions. The Contractor shall document these efforts fully, and shall implement affirmative action steps at least as extensive as the following:

AFFIRMATIVE ACTION STEPS TO ENSURE EQUAL EMPLOYMENT OPPORTUNITY

1. Ensure and maintain a working environment free of harassment, intimidation and coercion at all sites and in all facilities at which the Contractor's employees are assigned to work. The Contractor, where possible will assign two or more women to each construction project. The Contractor shall specifically ensure that all foremen, superintendents and other on-site supervisory personnel are aware of and carry out the Contractor's obligation to maintain such a working environment, with specific attention to minority or female individuals working as such sites or in such facilities.

2. Establish and maintain a current list of minority and female recruitment sources provide written notification to minority and female recruitment sources and to community organizations when the Contractor or its unions have employment opportunities available and maintain a record of the organization's responses.

3. Maintain a current file of the names, addresses and telephone numbers of each minority and female off-the-street applicant and minority or female referral from a union, a recruitment source or community organization and of what action was taken with respect to each such individual. If such individual was sent to the union hiring hall for referral and was not referred back to the Contractor by the union or, if referred, not employed by the Contractor, this shall be documented in the file with the reason therefore, along with whatever additional actions the Contractor may have taken.

4. Provide immediate written notification to the Director when the union or unions with which the Contractor has a collective bargaining agreement has not referred to the Contractor a minority person or woman sent by the Contractor, or when the Contractor has other information that the union referral process has impeded the Contractor's efforts to meet its obligations.
5. Develop on-the-job training opportunity and/or participate in training programs for the area which expressly include minorities and women, including upgrading programs and apprenticeship and trainee programs relevant to the Contractor's employment needs, especially those programs funded or approved by the Department of Labor. The Contractor shall provide notice of these programs to the sources compiled under Step #2.
6. Disseminate the Contractor's EEO policy by providing notice of the policy to unions and training programs and requesting their cooperation in assisting the Contractor in meeting its EEO obligations; by including it in any policy manual and collective bargaining agreement; by publicizing it in the company newspaper, annual report, etc. by specific review of the policy with all management personnel and with all minority and female employees at least once a year, and by posting the company EEO policy on bulletin boards accessible to all employees at each location where construction is performed.
7. Review, at least annually the company's EEO policy and affirmative obligations under these specifications with all employees having any responsibility for hiring, assignment, layoff, termination or other employment decisions including specific review of these terms with on-site supervisory personnel such as Superintendents, General foremen, etc. prior to the initiation of construction work at any job site. A written record shall be made and maintained identifying the time and place of these meetings, persons attending, subject matter discussed, and disposition of the subject matter.
8. Disseminate the Contractor's EEO policy externally by including it in any advertising in the news media, specifically including minority and female news media, and providing written notification to and discussing the Contractor's and Subcontractors with whom the Contractor does or anticipate doing business.
9. Direct its recruitment efforts, both oral and written to minority, female and community organizations, to schools with minority and female students and to minority and female recruitment and training organizations serving the Contractor's recruitment area and employment needs. Not later than one month prior to the date for the acceptance of applications for apprenticeship or other training by any recruitment source, the Contractor shall send written notification to organizations such as the above, describing the openings, screening procedures and tests to be used in the selection process.
10. Encourage present minority and female employees to recruit other minority persons and women and, where reasonable provide after school, summer and vacation employment to minority and female youth both on the site and in other areas of a Contractor's workforce.
11. Validate all test and other selection requirements where there is an obligation to do so under 41 CFR Part 60-3.

12. Conduct, at least annually, an inventory and evaluation at least of all minority and female personnel for promotional opportunities and encourage these employees to seek or to prepare for, through appropriate training, etc. such opportunities.

13. Ensure that seniority practices, job classifications, work assignments and other personnel practices, do not have a discriminatory effect by continually monitoring all personnel and employment related activities to ensure that the EEO policy and the Contractor's obligations under these specifications are being carried out.

14. Ensure that all facilities and company activities are non-segregated except that separate or single-user and necessary changing facilities shall be provided to assure privacy between the sexes.

15. Document and maintain a record of all solicitations of offers for subcontracts from minority and female construction contractors and suppliers including circulation of solicitations to minority and female contractor associations.

16. Conduct a review, at least annually, of all supervisors' adherence to and performance under the Contractor's EEO policies and affirmative action obligations.

Attachment B

EQUAL OPPORTUNITY CLAUSE

The applicant agrees that it will incorporate or cause to be incorporated into any contract for construction work, or modification thereof, as defined in the regulations of the Secretary of Labor at 41 CFR Chapter 60, which is paid for in whole or in part with funds obtained from the Federal Government or borrowed on the credit of the Federal Government pursuant to a grant contract, loan, insurance, or guarantee, or undertaken pursuant to any Federal program involving such a grant, contract, loan, insurance or guarantee, the following equal opportunity clause.

During the performance of this contract, the contractor agrees as follows:

1. The contractor will not discriminate against any employee or applicant for employment because of race, color, religion, sex, or national origin. The contractor will take affirmative action to ensure that applicants are employed, and that employees are treated during employment without regard to their race color, religion, sex, or national origin. Such action shall include, but not be limited to the following: employment, upgrading, demotion, or transfer, recruitment or recruitment advertising, layoff or termination; rates of pay, or other forms of compensation; and selection for training, including apprenticeship. The contractor agrees to post in conspicuous places, available to employees and applicants for employment, notices to be provided setting forth the provisions of this non-discrimination clause.
2. The contractor will, in all solicitations or advertisements for employees placed by or on behalf of the contractor, state that all qualified applicants will receive consideration for employment without regard to race, color, religion, sex, or national or national origin.
3. The contractor will send to each labor union or representative of workers with which he has a collective bargaining agreement or other contract or understanding, a notice to be provided advising the said labor union or workers representatives of the contractors' commitments under this section and shall post copies of the notice in conspicuous places available to employees and applicants for employment.
4. The contractor will comply with all provisions of Executive Order 11246 of September 24, 1965, and of the rules, regulations and relevant orders of the Secretary of Labor.
5. The contractor will furnish all information and reports required by Executive Order 112456 of September 24, 1965, and by rules, regulations and orders of the Secretary of Labor, or pursuant thereto, and will permit access to his books, records and accounts by the administering agency and the Secretary of Labor for purposes to ascertain compliance with such rules, regulations and orders.

6. In the event of the contractor's non-compliance with the non-discrimination clauses of this contract or with any of the said rules, regulations, or orders, this contract may be canceled, terminated, or suspended in whole or in part and the contractor may be declared ineligible for further Government contracts or federally assisted construction contracts in accordance with procedures authorized in Executive Order 11246 of September 24, 1965, and such other sanctions may be imposed and remedies invoked as provided in Executive Order 11246 of September 24, 1965, or by rule, regulation, or order of the Secretary of Labor, or as otherwise provided by law.

7. The contractor will include the portion of the sentence immediately preceding paragraph (1) and the provisions of paragraphs (1) through (7) in every subcontract or purchase order unless exempted by rules, regulations, or orders of the Secretary of Labor issued pursuant to section 204 of Executive Order 11246 of September 24, 1965, so that such provisions will be binding upon each subcontractor or vendor. The contractor will take such action with respect to any subcontract or purchase order as the administering agency may direct as a means of enforcing such provisions, including sanctions for non-compliance: Provided however, that in the event a contractor becomes involved in, or is threatened with litigation with a subcontractor or vendor as a result of such direction by the administering agency, the contractor may request the United States to enter into such litigation to protect the interests of the United States.

The applicant further agrees that it will be bound by the above equal opportunity clause with respect to its own employment practices when it participates in federally assisted construction work: Provided that if the applicant so participating is a state or local government the above equal opportunity clause is not applicable to any agency, instrumentality or subdivision of such government which does not participate in work on or under the contract.

The applicant agrees that it will assist and cooperate actively with the administering agency and the Secretary of Labor in obtaining the compliance of contractors and subcontractors with the equal opportunity clause and the rules, regulations and relevant orders of the Secretary of Labor, that it will furnish the administering agency and the Secretary of Labor such information as they may require for the supervision of such compliance, and that it will otherwise assist the administering agency in the discharge of the agency's primary responsibilities for securing compliance.

The applicant further agrees that it will refrain from entering into any contract or contract modification subject to Executive Order 11246 of September 24, 1965, with a contractor debarred from, or who has not demonstrated eligibility for, Government contracts and federally assisted construction contracts pursuant to the Executive Order and will carry out such sanctions and penalties for violation of the equal opportunity clause as may be imposed upon contractors and subcontractors by the administering agency or the Secretary of Labor pursuant to Part II, Subpart D of the Executive Order. In addition, the applicant agrees that if it fails or refuses to comply with these undertakings, the administering agency may take any or all of the following actions:

Cancel, terminate, or suspend in whole or in part this grant (contract, loan, insurance, guarantee): refrain from extending any further assistance to the applicant under the program with respect to which the failure or refund occurred until satisfactory assurance of future compliance has been received from such applicant; and refer the case to the Department of Justice for appropriate legal proceedings.

Attachment C

Standard Federal Equal Employment
Opportunity Construction Specifications

(Executive Order 11246)

1. As used in these specifications:

a. "Covered area" means the geographical area described in the solicitation from which this contract resulted

b. "Director" means director, Office of Federal Contract Compliance Programs, United States Department of Labor, or any person to whom the Director delegates authority.

c. "Employer Identification Number" means the Federal Social Security number used on the Employers Quarterly Federal Tax Return, U.S. Treasury Department Form 941.

d. "Minority" includes: Black (all persons having origins in any of the Black African racial groups not of Hispanic origin); Hispanic (all persons of Mexican, Puerto, Rican, Cuban, Central or South American or other Spanish culture or origin, regardless of race; Asian and Pacific Islander (all persons having origins in any of the original peoples of the Far East, Southeast Asia, the Indian Subcontinent or the Pacific Islands) and American Indian or Alaskan Native (all persons having origins in any of the original peoples of North America and maintaining identifiable tribal affiliations through membership and participation or community identification).

2. Whenever the Contractor, or any Subcontractor at any tier, subcontracts a portions of the work involving any construction trade it shall physically include in each subcontracts in excess of \$10,000 the provisions of these specifications and the Notice which contains the applicable goals for minority and female participation and which is set forth in the solicitations from which the contract resulted.

3. If the Contractor is participating (pursuant to 41 CFR 60-4.5) in a Hometown Plan approved by the U.S. Department of Labor in the covered area either individually or through an association, its affirmative action obligations on all work in the Plan area (including goals and timetables) shall be in accordance with that Plan for those trades which have unions participating in the Plan. Contractors must be able to demonstrate their participation in and compliance with the provisions of any such Hometown Plan. Each contractor or Subcontractor participating in an approved Plan is individually required to comply with its obligations under the EEO clause, and to make a good faith effort to achieve each goal under the Plan in each trade in which it has employees. The overall good faith performance by other Contractors or Subcontractors toward a goal in an approved Plan does not excuse any covered Contractor's or Subcontractor's failure to make good faith efforts to achieve the Plan goals and timetables.

4. The Contractor shall implement the specific affirmative action standards provided in paragraphs 7a through p of these specifications. the goals set forth in the solicitation from which this contract resulted are expressed as percentages of the total hours of employment and training of minority and female utilization the Contractor should reasonably be able to achieve in each construction trade in which it has employees in the covered area. The Contractor is expected to make substantially uniform progress toward its goal in each craft during the period specified.

5. Neither the provisions of any collective bargaining agreement, nor the failure by a union with whom the Contractor has a collective bargaining agreement, to refer either minorities or women shall excuse the contractor's obligations under these specifications, Executive Order 11246, or the regulations promulgated pursuant thereto.

6. In order for the non-working training hours of apprentices and trainees to be counted in meeting the goals, such apprentices and trainees must be employed by the Contractor during the training period, and the contractor must have made a commitment to employ the apprentices and trainees at the completion of their training, subject to the availability of employment opportunity. Trainees must be trained pursuant to training programs approved by the U.S. Department of Labor.

7. The Contractor shall take specific affirmative actions to ensure equal employment opportunity. The evaluation of the Contractor's compliance with these specifications shall be based upon its effort to achieve maximum results from its actions. The Contractor shall document these efforts fully, and shall implement affirmative action steps at least as extensive as the follows:

- a. Ensure and maintain a working environment free of harassment, intimidation and coercion at all sites and in all facilities at which the contractor's employees are assigned to work. The contractor where possible, will assign two or more women to each construction project. The contractor shall specifically ensure that all foremen, superintendents and other on-site supervisory personnel are aware of and carry out the contractor's obligation to maintain such a working environment, with specific attention to minority or female individuals working at such sites or in such facilities.
- b. Establish and maintain a current list of minority and female recruitment sources, provide written notification to minority and female recruitment sources and to community organizations when the contractor or its unions have employment opportunities available, and maintain a record of the organization's responses.
- c. Maintain a current file of the names, addresses and telephone numbers of each minority and female off-the-street applicant and minority or female referral from a union, a recruitment source or community organization and of what action was taken with respect to each such individual.

If such individual was sent to the union hiring hall for referral and was not referred back to the contractor by the union or, if referred, not employed by the contractor, this shall be documented in the file with the reason therefore, along with whatever additional actions the contractor may have taken.

- d. Provide immediate written notification to the Director when the union or unions with which the contractor has a collective bargaining agreement has not referred to the contractor a minority person or women sent by the contractor has other information that the union referral process has impeded the contractor's efforts to meet its obligations.
- e. Develop on-the-job training opportunity and/or participate in training programs for the area which expressly include minorities and women, including upgrading programs and apprenticeship and trainee programs relevant to the Contractor's employment needs, especially those programs funded or approved by the Department of Labor. The Contractor shall provide notice of these programs to the source complied under 7b above.
- f. Disseminate the contractor's EEO policy by providing notice of the policy by providing notice of the policy to unions and training programs and requesting their cooperation in assisting the Contractor in meeting its EEO obligations; by including it in any policy manual and collective bargaining agreement; by publicizing it in the company newspaper, annual report, etc. by specific review of the policy with all management personnel and with all minority and female employees at least once a year, and by posting the company EEO policy bulletin boards accessible to all employees at each location where construction work is performed.
- g. Review, at least annually, the company's EEO policy and affirmative action obligations under these specifications with all employees having any responsibility for hiring, assignment, layoff, termination or other employment decisions including specific review of these terms with on-site supervisory personnel such as Superintendents, General Foremen, etc., prior to the initiation of construction work at any job site. A written record shall be made and maintained identifying the time and place of these meetings, persons attending, subject matter discussed and disposition of the subject matter.
- h. Disseminate the contractor's EEO policy externally by including it in any advertising in the news media, specifically including minority and female news media and providing written notification to and discussing the contractor's EEO policy with other contractors and subcontractors with whom the contractor does or anticipates doing business.

- i. Direct its recruitment efforts, both oral and written, to minority, female and community organizations, to schools with minority and female students and to minority and female recruitment and training organizations serving the contractor's recruitment area and employment needs. Not later than one month prior to the date for the acceptance of applications for apprenticeship or other training by any recruitment source, the contractor shall send written notification to organizations such as the above, describing the openings, screening procedures and tests to be used in the selection process.
- j. Encourage present minority and female employees to recruit other minority persons and women and, where reasonable, provide after school, summer and vacation employment to minority and female youth both on the site and in other areas of a contractor's workforce.
- k. Validate all tests and other selection requirements where there is an obligation to do so under 41 CFR Part 60-3.
- l. Conduct, at least annually, an inventory and evaluation at least of all minority and female personnel for promotional opportunities and encourage these employees to seek or to prepare for, thorough appropriate training, etc. such opportunities.
- m. Ensure that seniority practices, job classification, work assignments and other personnel practices, do not have a discriminatory effect by continually monitoring all personnel and employment related activities to ensure that the EEO policy and the contractor's obligations under these specifications are being carried out.
- n. Ensure that all facilities and company activities are non-segregated except that separate or single-user toilet and necessary changing facilities shall be provided to assure privacy between the sexes.
- o. Document and maintain a record of all solicitations of offers for subcontracts from minority and female contractors and suppliers including circulation of solicitations to minority and female contractor associations.
- p. Conduct a review, at least annually, of all supervisors' adherence to and performance under the contractor's EEO policies and affirmative action obligations.

8. Contractors are encouraged to participate in voluntary associations which assist in fulfilling one or more of their affirmative action obligations (7a through p). The efforts of a contractor association, joint contractor-union, contractor-community, or other similar group of which the contractor is a member and a participant, may be asserted as fulfilling any one or more of its obligations under 7a through p of these specifications provided that the contractor actively participates in the group, makes every effort to assure that the group has a positive impact on the employment of minorities and women in the industry, ensures that the concrete benefits of the program are reflected in the contractor's minority and female workforce participation, makes a good faith effort to meet its individual goals and timetables, and can provide access to documentation which demonstrates the effectiveness of actions taken on behalf of the contractor. The obligation to comply, however, is the contractor's and failure of such a group to fulfill an obligation shall to be a defense for the contractor's noncompliance.

9. A single goal for minorities and a separate single goal for women have been established. The contractor, however, is required to provide equal employment opportunity and to take affirmative action for all minority groups, both male and female, and all women, both minority and non-minority. Consequently, the contractor may be in violation of the Executive Order if a particular group is employed in a substantially disparate manner (for example, even though the contractor has achieved its goals for women generally, the contractor may also be in violation of the Executive Order if a specific minority group of women is under-utilized).

10. The contractor shall not use the goals and timetables or affirmative action standards to discriminate against any person because of race, color, religion, sex or national origin.

11. The contractor shall not enter into any subcontract with any person or firm debarred from Government contracts pursuant to Executive Order 11246.

12. The contractor shall carry out such sanctions and penalties for violation of these specifications and of the Equal Opportunity Clause, including suspension, termination and cancellation of existing subcontracts as may be imposed or ordered pursuant to Executive Order 11246, as amended, and its implementing regulations, by the Office of Federal Contract Compliance Programs. Any Contractor who fails to carry out such sanctions and penalties shall be in violation of these specifications, and Executive Order 11246, as amended.

13. The contractor, in fulfilling its obligations under these specifications shall implement affirmative action steps at least as extensive as those standards prescribed in paragraph 7 of these specifications so as to achieve maximum results from its efforts to ensure equal employment opportunity. If the contractor fails to comply with the requirements of the Executive Order, the implementing regulations, or these specifications, the Director shall proceed in accordance with 41 CFR 60-4-3.

14. The contractor shall designate a responsible official to monitor all employment related activity to ensure that the company EEO policy is being carried out to the provisions hereof as may be required by the Government and to keep records which shall at least include for each employee the name, address, telephone numbers, contraction trade, union affiliation, if any, employee identification number when assigned, social security number, race, sex, status, i.e. mechanic, apprentice, trainee, helper or laborer, dates of changes in status, hours worked per week in the indicated trade, rate of pay and locations at which the work was performed. Records shall be maintained in an easily understandable form; however, to the degree that existing records satisfy this requirement, contractors shall not be required to maintain separate records.

15. Nothing herein provided shall be construed as a limitation upon the application of other laws which establish different standards of compliance or upon the application of requirements for the hiring of local or other area residents (e.g. those under the Public Works Employment Act of 1977 and the Community Development Block Grant Program).

MINORITY CONTRACTOR PARTICIPATION

Name of Prime Bidder

Indicate whether or not you will be subcontracting a portion of this contract to a minority business ___Yes ___No

If yes, list the names of minority subcontractors who will be performing work for you.

Type of Work (Electrical, Paving, etc.) and Name of Contract items

Minority Contractor	Address	Parts thereof to be performed	Agreed Price
---------------------	---------	-------------------------------	--------------

NOTE: Minority person means an individual who is Black, Hispanic, Asian American, American Indian, Alaskan Native or a woman regardless of race or ethnicity.

Minority contractor means a contractor which is:

1) an individual, who is a Minority Person, 2) a partnership or joint venture controlled by minority persons and in which at least 51 percent of the beneficial ownership interests are held by minority persons, or 3) a corporation or other entity controlled by Minority Persons in which at least 51 percent of voting interest and beneficial ownership interests are held by Minority Persons.

COMPLIANCE WITH OTHER FEDERAL REGULATIONS

The Contractor/Subcontractor shall comply with the following Federal regulations where applicable. The regulations are incorporated herein by reference.

Nondiscrimination under Title VI of the Civil Rights Act of 1964 as amended

Flood Disaster Protection Act of 1973 (P.L. 93-243)

HUD Lead-Based Paint Regulations, 24 CFR Part 35

Clean Air Act, as amended, 42 USC 1857 et seq.

Federal Water Pollution Control Act, as amended 33 USC 1251 et seq.

Regulations of Environmental Protection Agency, 40 CFR Part 15, as amended

Section 504 of the Rehabilitation Act of 1973 (Pub L. 93-112), as amended and implementing regulations when published for effect.

Records retention for 3 years pertaining to work bid upon.

Federal Labor Standards Provisions

U.S. Department of Housing and Urban Development Office of Labor Relations

Applicability

The Project or Program to which the construction work covered by this contract pertains is being assisted by the United States of America and the following Federal Labor Standards Provisions are included in this Contract pursuant to the provisions applicable to such Federal assistance.

A. 1. (i) Minimum Wages. All laborers and mechanics employed or working upon the site of the work, will be paid unconditionally and not less often than once a week, and without subsequent deduction or rebate on any account (except such payroll deductions as are permitted by regulations issued by the Secretary of Labor under the Copeland Act (29 CFR Part 3), the full amount of wages and bona fide fringe benefits (or cash equivalents thereof) due at time of payment computed at rates not less than those contained in the wage determination of the Secretary of Labor which is attached hereto and made a part hereof, regardless of any contractual relationship which may be alleged to exist between the contractor and such laborers and mechanics. Contributions made or costs reasonably anticipated for bona fide fringe benefits under Section I(b)(2) of the Davis-Bacon Act on behalf of laborers or mechanics are considered wages paid to such laborers or mechanics, subject to the provisions of 29 CFR 5.5(a)(1)(iv); also, regular contributions made or costs incurred for more than a weekly period (but not less often than quarterly) under plans, funds, or programs, which cover the particular weekly period, are deemed to be constructively made or incurred during such weekly period.

Such laborers and mechanics shall be paid the appropriate wage rate and fringe benefits on the wage determination for the classification of work actually performed, without regard to skill, except as provided in 29 CFR 5.5(a)(4). Laborers or mechanics performing work in more than one classification may be compensated at the rate specified for each classification for the time actually worked therein: Provided, That the employer's payroll records accurately set forth the time spent in each classification in which work is performed. The wage determination (including any additional classification and wage rates conformed under 29 CFR 5.5(a)(1)(ii) and the Davis-Bacon poster (WH-1321) shall be posted at all times by the contractor and its subcontractors at the site of the work in a prominent and accessible, place where it can be easily seen by the workers.

(ii) (a) Any class of laborers or mechanics which is not listed in the wage determination and which is to be employed under the contract shall be classified in conformance with the wage determination. HUD shall approve an additional classification and wage rate and fringe benefits therefor only when the following criteria have been met:

(1) The work to be performed by the classification requested is not performed by a classification in the wage determination; and

(2) The classification is utilized in the area by the construction industry; and

(3) The proposed wage rate, including any bona fide fringe benefits, bears a reasonable relationship to the wage rates contained in the wage determination.

(b) If the contractor and the laborers and mechanics to be employed in the classification (if known), or their representatives, and HUD or its designee agree on the classification and wage rate (including the amount designated for fringe benefits where appropriate), a report of the action taken shall be sent by HUD or its designee to the Administrator of the Wage and Hour Division, Employment Standards Administration, U.S. Department of Labor, Washington, D.C. 20210. The Administrator, or an authorized representative, will approve, modify, or disapprove every additional classification action within 30 days of receipt and so advise HUD or its designee or will notify HUD or its designee within the 30-day period that additional time is necessary. (Approved by the Office of Management and Budget under OMB control number 1215-0140.)

(c) In the event the contractor, the laborers or mechanics to be employed in the classification or their representatives, and HUD or its designee do not agree on the proposed classification and wage rate (including the amount designated for fringe benefits, where appropriate), HUD or its designee shall refer the questions, including the views of all interested parties and the recommendation of HUD or its designee, to the Administrator for determination. The Administrator, or an authorized representative, will issue a determination within 30 days of receipt and so advise HUD or its designee or will notify HUD or its designee within the 30-day period that additional time is necessary. (Approved by the Office of Management and Budget under OMB Control Number 1215-0140.)

(d) The wage rate (including fringe benefits where appropriate) determined pursuant to subparagraphs (1)(ii)(b) or (c) of this paragraph, shall be paid to all workers performing work in the classification under this contract from the first day on which work is performed in the classification.

(iii) Whenever the minimum wage rate prescribed in the contract for a class of laborers or mechanics includes a fringe benefit which is not expressed as an hourly rate, the contractor shall either pay the benefit as stated in the wage determination or shall pay another bona fide fringe benefit or an hourly cash equivalent thereof.

(iv) If the contractor does not make payments to a trustee or other third person, the contractor may consider as part

of the wages of any laborer or mechanic the amount of any costs reasonably anticipated in providing bona fide fringe benefits under a plan or program, Provided, That the Secretary of Labor has found, upon the written request of the contractor, that the applicable standards of the Davis-Bacon Act have been met. The Secretary of Labor may require the contractor to set aside in a separate account assets for the meeting of obligations under the plan or program. (Approved by the Office of Management and Budget under OMB Control Number 1215-0140.)

2. Withholding. HUD or its designee shall upon its own action or upon written request of an authorized representative of the Department of Labor withhold or cause to be withheld from the contractor under this contract or any other Federal contract with the same prime contractor, or any other Federally-assisted contract subject to Davis-Bacon prevailing wage requirements, which is held by the same prime contractor so much of the accrued payments or advances as may be considered necessary to pay laborers and mechanics, including apprentices, trainees and helpers, employed by the contractor or any subcontractor the full amount of wages required by the contract. In the event of failure to pay any laborer or mechanic, including any apprentice, trainee or helper, employed or working on the site of the work, all or part of the wages required by the contract, HUD or its designee may, after written notice to the contractor, sponsor, applicant, or owner, take such action as may be necessary to cause the suspension of any further payment, advance, or guarantee of funds until such violations have ceased. HUD or its designee may, after written notice to the contractor, disburse such amounts withheld for and on account of the contractor or subcontractor to the respective employees to whom they are due. The Comptroller General shall make such disbursements in the case of direct Davis-Bacon contracts.

3. (i) Payrolls and basic records. Payrolls and basic records relating thereto shall be maintained by the contractor during the course of the work preserved for a period of three years thereafter for all laborers and mechanics working at the site of the work. Such records shall contain the name, address, and social security number of each such worker, his or her correct classification, hourly rates of wages paid (including rates of contributions or costs anticipated for bona fide fringe benefits or cash equivalents thereof of the types described in Section 1(b)(2)(B) of the Davis-bacon Act), daily and weekly number of hours worked, deductions made and actual wages paid. Whenever the Secretary of Labor has found under 29 CFR 5.5 (a)(1)(iv) that the wages of any laborer or mechanic include the amount of any costs reasonably anticipated in providing benefits under a plan or program described in Section 1(b)(2)(B) of the Davis-Bacon Act, the contractor shall maintain records which show that the commitment to provide such benefits is enforceable, that the plan or program is financially responsible, and that the plan or program has been

communicated in writing to the laborers or mechanics affected, and records which show the costs anticipated or the actual cost incurred in providing such benefits. Contractors employing apprentices or trainees under approved programs shall maintain written evidence of the registration of apprenticeship programs and certification of trainee programs, the registration of the apprentices and trainees, and the ratios and wage rates prescribed in the applicable programs. (Approved by the Office of Management and Budget under OMB Control Numbers 1215-0140 and 1215-0017.)

(ii) (a) The contractor shall submit weekly for each week in which any contract work is performed a copy of all payrolls to HUD or its designee if the agency is a party to the contract, but if the agency is not such a party, the contractor will submit the payrolls to the applicant sponsor, or owner, as the case may be, for transmission to HUD or its designee. The payrolls submitted shall set out accurately and completely all of the information required to be maintained under 29 CFR 5.5(a)(3)(i) except that full social security numbers and home addresses shall not be included on weekly transmittals. Instead the payrolls shall only need to include an individually identifying number for each employee (e.g., the last four digits of the employee's social security number). The required weekly payroll information may be submitted in any form desired. Optional Form WH-347 is available for this purpose from the Wage and Hour Division Web site at <http://www.dol.gov/esa/whd/forms/wh347instr.htm> or its successor site. The prime contractor is responsible for the submission of copies of payrolls by all subcontractors. Contractors and subcontractors shall maintain the full social security number and current address of each covered worker, and shall provide them upon request to HUD or its designee if the agency is a party to the contract, but if the agency is not such a party, the contractor will submit the payrolls to the applicant sponsor, or owner, as the case may be, for transmission to HUD or its designee, the contractor, or the Wage and Hour Division of the Department of Labor for purposes of an investigation or audit of compliance with prevailing wage requirements. It is not a violation of this subparagraph for a prime contractor to require a subcontractor to provide addresses and social security numbers to the prime contractor for its own records, without weekly submission to HUD or its designee. (Approved by the Office of Management and Budget under OMB Control Number 1215-0149.)

(b) Each payroll submitted shall be accompanied by a "Statement of Compliance," signed by the contractor or subcontractor or his or her agent who pays or supervises the payment of the persons employed under the contract and shall certify the following:

(1) That the payroll for the payroll period contains the information required to be provided under 29 CFR 5.5 (a)(3)(ii), the appropriate information is being maintained under 29 CFR 5.5(a)(3)(i), and that such information is correct and complete;

(2) That each laborer or mechanic (including each helper, apprentice, and trainee) employed on the contract during the payroll period has been paid the full weekly wages earned, without rebate, either directly or indirectly, and that no deductions have been made either directly or indirectly from the full wages earned, other than permissible deductions as set forth in 29 CFR Part 3;

(3) That each laborer or mechanic has been paid not less than the applicable wage rates and fringe benefits or cash equivalents for the classification of work performed, as specified in the applicable wage determination incorporated into the contract.

(c) The weekly submission of a properly executed certification set forth on the reverse side of Optional Form WH-347 shall satisfy the requirement for submission of the "Statement of Compliance" required by subparagraph A.3.(ii)(b).

(d) The falsification of any of the above certifications may subject the contractor or subcontractor to civil or criminal prosecution under Section 1001 of Title 18 and Section 231 of Title 31 of the United States Code.

(iii) The contractor or subcontractor shall make the records required under subparagraph A.3.(i) available for inspection, copying, or transcription by authorized representatives of HUD or its designee or the Department of Labor, and shall permit such representatives to interview employees during working hours on the job. If the contractor or subcontractor fails to submit the required records or to make them available, HUD or its designee may, after written notice to the contractor, sponsor, applicant or owner, take such action as may be necessary to cause the suspension of any further payment, advance, or guarantee of funds. Furthermore, failure to submit the required records upon request or to make such records available may be grounds for debarment action pursuant to 29 CFR 5.12.

4. Apprentices and Trainees.

(i) **Apprentices.** Apprentices will be permitted to work at less than the predetermined rate for the work they performed when they are employed pursuant to and individually registered in a bona fide apprenticeship program registered with the U.S. Department of Labor, Employment and Training Administration, Office of Apprenticeship Training, Employer and Labor Services, or with a State Apprenticeship Agency recognized by the Office, or if a person is employed in his or her first 90 days of probationary employment as an apprentice in such an apprenticeship program, who is not individually registered in the program, but who has been certified by the Office of Apprenticeship Training, Employer and Labor Services or a State Apprenticeship Agency (where appropriate) to be eligible for probationary employment as an apprentice. The allowable ratio of apprentices to journeymen on the job site in any craft classification shall not be greater than the ratio permitted to the contractor as to the entire work force under the registered program. Any worker listed on a payroll at an apprentice wage rate, who

is not registered or otherwise employed as stated above, shall be paid not less than the applicable wage rate on the wage determination for the classification of work actually performed. In addition, any apprentice performing work on the job site in excess of the ratio permitted under the registered program shall be paid not less than the applicable wage rate on the wage determination for the work actually performed. Where a contractor is performing construction on a project in a locality other than that in which its program is registered, the ratios and wage rates (expressed in percentages of the journeyman's hourly rate) specified in the contractor's or subcontractor's registered program shall be observed. Every apprentice must be paid at not less than the rate specified in the registered program for the apprentice's level of progress, expressed as a percentage of the journeymen hourly rate specified in the applicable wage determination. Apprentices shall be paid fringe benefits in accordance with the provisions of the apprenticeship program. If the apprenticeship program does not specify fringe benefits, apprentices must be paid the full amount of fringe benefits listed on the wage determination for the applicable classification. If the Administrator determines that a different practice prevails for the applicable apprentice classification, fringes shall be paid in accordance with that determination. In the event the Office of Apprenticeship Training, Employer and Labor Services, or a State Apprenticeship Agency recognized by the Office, withdraws approval of an apprenticeship program, the contractor will no longer be permitted to utilize apprentices at less than the applicable predetermined rate for the work performed until an acceptable program is approved.

(ii) **Trainees.** Except as provided in 29 CFR 5.16, trainees will not be permitted to work at less than the predetermined rate for the work performed unless they are employed pursuant to and individually registered in a program which has received prior approval, evidenced by formal certification by the U.S. Department of Labor, Employment and Training Administration. The ratio of trainees to journeymen on the job site shall not be greater than permitted under the plan approved by the Employment and Training Administration. Every trainee must be paid at not less than the rate specified in the approved program for the trainee's level of progress, expressed as a percentage of the journeyman hourly rate specified in the applicable wage determination. Trainees shall be paid fringe benefits in accordance with the provisions of the trainee program. If the trainee program does not mention fringe benefits, trainees shall be paid the full amount of fringe benefits listed on the wage determination unless the Administrator of the Wage and Hour Division determines that there is an apprenticeship program associated with the corresponding journeyman wage rate on the wage determination which provides for less than full fringe benefits for apprentices. Any employee listed on the payroll at a trainee rate who is not registered and participating in a training plan approved by

the Employment and Training Administration shall be paid not less than the applicable wage rate on the wage determination for the work actually performed. In addition, any trainee performing work on the job site in excess of the ratio permitted under the registered program shall be paid not less than the applicable wage rate on the wage determination for the work actually performed. In the event the Employment and Training Administration withdraws approval of a training program, the contractor will no longer be permitted to utilize trainees at less than the applicable predetermined rate for the work performed until an acceptable program is approved.

(iii) Equal employment opportunity. The utilization of apprentices, trainees and journeymen under 29 CFR Part 5 shall be in conformity with the equal employment opportunity requirements of Executive Order 11246, as amended, and 29 CFR Part 30.

5. Compliance with Copeland Act requirements. The contractor shall comply with the requirements of 29 CFR Part 3 which are incorporated by reference in this contract

6. Subcontracts. The contractor or subcontractor will insert in any subcontracts the clauses contained in subparagraphs 1 through 11 in this paragraph A and such other clauses as HUD or its designee may by appropriate instructions require, and a copy of the applicable prevailing wage decision, and also a clause requiring the subcontractors to include these clauses in any lower tier subcontracts. The prime contractor shall be responsible for the compliance by any subcontractor or lower tier subcontractor with all the contract clauses in this paragraph.

7. Contract termination; debarment. A breach of the contract clauses in 29 CFR 5.5 may be grounds for termination of the contract and for debarment as a contractor and a subcontractor as provided in 29 CFR 5.12.

8. Compliance with Davis-Bacon and Related Act Requirements. All rulings and interpretations of the Davis-Bacon and Related Acts contained in 29 CFR Parts 1, 3, and 5 are herein incorporated by reference in this contract

9. Disputes concerning labor standards. Disputes arising out of the labor standards provisions of this contract shall not be subject to the general disputes clause of this contract. Such disputes shall be resolved in accordance with the procedures of the Department of Labor set forth in 29 CFR Parts 5, 6, and 7. Disputes within the meaning of this clause include disputes between the contractor (or any of its subcontractors) and HUD or its designee, the U.S. Department of Labor, or the employees or their representatives.

10. (i) Certification of Eligibility. By entering into this contract the contractor certifies that neither it (nor he or she) nor any person or firm who has an interest in the contractor's firm is a person or firm ineligible to be awarded Government contracts by virtue of Section 3(a) of the Davis-Bacon Act or 29 CFR 5.12(a)(1) or to be

awarded HUD contracts or participate in HUD programs pursuant to 24 CFR Part 24.

(ii) No part of this contract shall be subcontracted to any person or firm ineligible for award of a Government contract by virtue of Section 3(a) of the Davis-Bacon Act or 29 CFR 5.12(a)(1) or to be awarded HUD contracts or participate in HUD programs pursuant to 24 CFR Part 24.

(iii) The penalty for making false statements is prescribed in the U.S. Criminal Code, 18 U.S.C. 1001. Additionally, U.S. Criminal Code, Section 1 01 0, Title 18, U.S.C., "Federal Housing Administration transactions", provides in part: "Whoever, for the purpose of . . . influencing in any way the action of such Administration..... makes, utters or publishes any statement knowing the same to be false..... shall be fined not more than \$5,000 or imprisoned not more than two years, or both."

11. Complaints, Proceedings, or Testimony by Employees. No laborer or mechanic to whom the wage, salary, or other labor standards provisions of this Contract are applicable shall be discharged or in any other manner discriminated against by the Contractor or any subcontractor because such employee has filed any complaint or instituted or caused to be instituted any proceeding or has testified or is about to testify in any proceeding under or relating to the labor standards applicable under this Contract to his employer.

B. Contract Work Hours and Safety Standards Act. The provisions of this paragraph B are applicable where the amount of the prime contract exceeds \$100,000. As used in this paragraph, the terms "laborers" and "mechanics" include watchmen and guards.

(1) Overtime requirements. No contractor or subcontractor contracting for any part of the contract work which may require or involve the employment of laborers or mechanics shall require or permit any such laborer or mechanic in any workweek in which the individual is employed on such work to work in excess of 40 hours in such workweek unless such laborer or mechanic receives compensation at a rate not less than one and one-half times the basic rate of pay for all hours worked in excess of 40 hours in such workweek.

(2) Violation; liability for unpaid wages; liquidated damages. In the event of any violation of the clause set forth in subparagraph (1) of this paragraph, the contractor and any subcontractor responsible therefor shall be liable for the unpaid wages. In addition, such contractor and subcontractor shall be liable to the United States (in the case of work done under contract for the District of Columbia or a territory, to such District or to such territory), for liquidated damages. Such liquidated damages shall be computed with respect to each individual laborer or mechanic, including watchmen and guards, employed in violation of the clause set forth in subparagraph (1) of this paragraph, in the sum of \$10 for each calendar day on which such individual was required or permitted to work in excess of the standard workweek of 40 hours without payment of the overtime wages required by the clause set forth in subparagraph (1) of this paragraph.

(3) Withholding for unpaid wages and liquidated damages. HUD or its designee shall upon its own action or upon written request of an authorized representative of the Department of Labor withhold or cause to be withheld, from any moneys payable on account of work performed by the contractor or subcontractor under any such contract or any other Federal contract with the same prime contract, or any other Federally-assisted contract subject to the Contract Work Hours and Safety Standards Act which is held by the same prime contractor such sums as may be determined to be necessary to satisfy any liabilities of such contractor or subcontractor for unpaid wages and liquidated damages as provided in the clause set forth in subparagraph (2) of this paragraph.

(4) Subcontracts. The contractor or subcontractor shall insert in any subcontracts the clauses set forth in subparagraph (1) through (4) of this paragraph and also a clause requiring the subcontractors to include these clauses in any lower tier subcontracts. The prime contractor shall be responsible for compliance by any subcontractor or lower tier subcontractor with the clauses set forth in subparagraphs (1) through (4) of this paragraph.

C. Health and Safety. The provisions of this paragraph C are applicable where the amount of the prime contract exceeds \$100,000.

(1) No laborer or mechanic shall be required to work in surroundings or under working conditions which are unsanitary, hazardous, or dangerous to his health and safety as determined under construction safety and health standards promulgated by the Secretary of Labor by regulation.

(2) The Contractor shall comply with all regulations issued by the Secretary of Labor pursuant to Title 29 Part 1926 and failure to comply may result in imposition of sanctions pursuant to the Contract Work Hours and Safety Standards Act, (Public Law 91-54, 83 Stat 96). 40 USC 3701 et seq.

(3) The contractor shall include the provisions of this paragraph in every subcontract so that such provisions will be binding on each subcontractor. The contractor shall take such action with respect to any subcontractor as the Secretary of Housing and Urban Development or the Secretary of Labor shall direct as a means of enforcing such provisions.

General Decision Number: RI160001 09/02/2016 RI1

Superseded General Decision Number: RI20150001

State: Rhode Island

Construction Types: Building, Heavy (Heavy and Marine) and Highway

Counties: Rhode Island Statewide.

BUILDING CONSTRUCTION PROJECTS (does not include residential construction consisting of single family homes and apartments up to and including 4 stories) HEAVY, HIGHWAY AND MARINE CONSTRUCTION PROJECTS

Note: Under Executive Order (EO) 13658, an hourly minimum wage of \$10.15 for calendar year 2016 applies to all contracts subject to the Davis-Bacon Act for which the solicitation was issued on or after January 1, 2015. If this contract is covered by the EO, the contractor must pay all workers in any classification listed on this wage determination at least \$10.15 (or the applicable wage rate listed on this wage determination, if it is higher) for all hours spent performing on the contract in calendar year 2016. The EO minimum wage rate will be adjusted annually. Additional information on contractor requirements and worker protections under the EO is available at www.dol.gov/whd/govcontracts.

Modification Number	Publication Date
0	01/08/2016
1	01/15/2016
2	01/29/2016
3	02/12/2016
4	02/19/2016
5	03/04/2016
6	03/11/2016
7	04/01/2016
8	05/06/2016
9	06/03/2016
10	06/10/2016
11	06/17/2016
12	06/24/2016
13	08/12/2016
14	09/02/2016

ASBE0006-006 06/01/2015

Rates

Fringes

HAZARDOUS MATERIAL HANDLER
 (Includes preparation,
 wetting, stripping, removal
 scrapping, vacuuming, bagging
 & disposing of all insulation
 materials, whether they
 contain asbestos or not, from
 mechanical systems).....\$ 31.63 18.30

 ASBE0006-008 09/01/2015

Rates Fringes

Asbestos Worker/Insulator
 Includes application of
 all insulating materials,
 protective coverings,
 coatings & finishes to all
 types of mechanical systems.\$ 39.43 25.65

 BOIL0029-001 01/01/2016

Rates Fringes

BOILERMAKER.....\$ 41.62 24.42

 BRRI0003-001 06/01/2016

Rates Fringes

Bricklayer, Stonemason,
 Pointer, Caulker & Cleaner.....\$ 37.38 24.73

 * BRRI0003-002 09/01/2016

Rates Fringes

Marble Setter, Terrazzo
 Worker & Tile Setter.....\$ 37.16 25.80

 * BRRI0003-003 09/01/2016

Rates Fringes

Marble, Tile & Terrazzo
 Finisher.....\$ 31.32 24.65

 CARP0094-001 06/06/2016

Rates Fringes

CARPENTER (Includes Soft
 Floor Layer).....\$ 34.91 25.85

Diver Tender.....	\$ 35.91	25.85
DIVER.....	\$ 46.71	25.85
Piledriver.....	\$ 34.91	25.85
WELDER.....	\$ 35.91	25.85

FOOTNOTES:

When not diving or tending the diver, the diver and diver tender shall receive the piledriver rate. Diver tenders shall receive \$1.00 per hour above the pile driver rate when tending the diver.

Work on free-standing stacks, concrete silos & public utility electrical power houses, which are over 35 ft. in height when constructed: \$.50 per hour additional.

Work on exterior concrete shear wall gang forms, 45 ft. or more above ground elevation or on setback: \$.50 per hour additional.

The designated piledriver, known as the "monkey": \$1.00 per hour additional.

 CARP1121-002 04/01/2016

	Rates	Fringes
MILLWRIGHT.....	\$ 34.95	26.77

 ELEC0099-002 06/01/2016

	Rates	Fringes
ELECTRICIAN.....	\$ 36.83	58.39%
Teledata System Installer.....	\$ 27.62	13.42%+13.57

FOOTNOTES:

Work of a hazardous nature, or where the work height is 30 ft. or more from the floor, except when working OSHA-approved lifts: 20% per hour additional.

Work in tunnels below ground level in combined sewer outfall: 20% per hour additional.

 ELEV0039-001 01/01/2016

	Rates	Fringes
ELEVATOR MECHANIC.....	\$ 47.37	29.985+A+B

FOOTNOTES:

A. PAID HOLIDAYS: New Years Day; Memorial Day; Independence Day; Labor Day; Veterans' Day; Thanksgiving Day; the Friday after Thanksgiving Day; and Christmas Day.

B. Employer contributes 8% basic hourly rate for 5 years or more of service of 6% basic hourly rate for 6 months to 5 years of service as vacation pay credit.

 ENGI0057-001 05/31/2016

	Rates	Fringes
Operating Engineer: (power plants, sewer treatment plants, pumping stations, tunnels, caissons, piers, docks, bridges, wind turbines, subterranean & other marine and heavy construction work)		
GROUP 1.....	\$ 36.15	24.85+a
GROUP 2.....	\$ 31.77	24.85+a
GROUP 3.....	\$ 28.92	24.85+a
GROUP 4.....	\$ 35.20	24.85+a
GROUP 5.....	\$ 26.00	24.85+a
GROUP 6.....	\$ 20.00	24.85+a
GROUP 7.....	\$ 31.85	24.85+a
GROUP 8.....	\$ 35.77	24.85+a

a. BOOM LENGTHS, INCLUDING JIBS:

- 150 feet and over + \$ 2.00
- 180 feet and over + \$ 3.00
- 210 feet and over + \$ 4.00
- 240 feet and over + \$ 5.00
- 270 feet and over + \$ 7.00
- 300 feet and over + \$ 8.00
- 350 feet and over + \$ 9.00
- 400 feet and over + \$10.00

a. PAID HOLIDAYS:

New Year's Day, President's Day, Memorial Day, July Fourth, Victory Day, Labor Day, Columbus Day, Veterans Day, Thanksgiving Day, Christmas Day. a: Any employee who works 3 days in the week in which a holiday falls shall be paid for the holiday.

a. FOOTNOTES:

- Hazmat work: \$2.00 per hour additional.
- Tunnel/Shaft work: \$5.00 per hour additional.

POWER EQUIPMENT OPERATORS CLASSIFICATIONS

GROUP 1: Digging machine, Ross Carrier, crane, lighter, locomotive, derrick, hoist, elevator, bidwell-type machine, shot & water blasting machine, paver, spreader, graders, front end loader (3 yds. and over), vibratory hammer & vacuum truck, roadheaders, forklifts, economobile type equipment, tunnel boring machines, concrete pump and on site concrete plants.

GROUP 2: Fireman & oiler.

GROUP 3: Oiler on crawler backhoe.

GROUP 4: Bulldozer, bobcats, skid steer loader, tractor, scraper, combination loader backhoe, roller, front end loader (less than 3 yds.), street and mobile-powered sweeper (3-yd. capacity), 8-ft. sweeper minimum 65 HP).

GROUP 5: Well-point installation crew.

GROUP 6: Utility Engineers and Signal Persons

GROUP 7: Heater, concrete mixer, stone crusher, welding machine, generator and light plant, gas and electric driven pump and air compressor.

GROUP 8: Boat & tug operator.

ENGI0057-002 05/02/2016

	Rates	Fringes
Power Equipment Operator (highway construction projects; water and sewerline projects which are incidental to highway construction projects; and bridge projects that do not span water)		
GROUP 1.....	\$ 31.30	24.85+a
GROUP 2.....	\$ 26.00	24.85+a
GROUP 3.....	\$ 20.00	24.85+a
GROUP 4.....	\$ 26.58	24.85+a
GROUP 5.....	\$ 30.28	24.85+a
GROUP 6.....	\$ 29.90	24.85+a
GROUP 7.....	\$ 25.55	24.85+a
GROUP 8.....	\$ 26.93	24.85+a
GROUP 9.....	\$ 28.88	24.85+a

a. FOOTNOTE: a. Any employee who works three days in the week in which a holiday falls shall be paid for the holiday.

a. PAID HOLIDAYS: New Year's Day, President's Day, Memorial Day, July Fourth, Victory Day, Labor Day, Columbus Day, Veterans Day, Thanksgiving Day & Christmas Day.

POWER EQUIPMENT OPERATOR CLASSIFICATIONS

GROUP 1: Digging machine, crane, piledriver, lighter, locomotive, derrick, hoist, boom truck, John Henry's, directional drilling machine, cold planer, reclaimer, paver, spreader, grader, front end loader (3 yds. and over), vacuum truck, test boring machine operator, veemere saw, water blaster, hydro-demolition robot, forklift, economobile, Ross Carrier, concrete pump operator and boats

GROUP 2: Well point installation crew

GROUP 3: Utility engineers and signal persons

GROUP 4: Oiler on cranes

GROUP 5: Combination loader backhoe, front end loader (less than 3 yds.), forklift, bulldozers & scrapers and boats

GROUP 6: Roller, skid steer loaders, street sweeper

GROUP 7: Gas and electric drive heater, concrete mixer, light plant, welding machine, pump & compressor

GROUP 8: Stone crusher

GROUP 9: Mechanic & welder

ENGI0057-003 05/31/2016

BUILDING CONSTRUCTION

	Rates	Fringes
Power Equipment Operator		
GROUP 1.....	\$ 35.42	24.85+a
GROUP 2.....	\$ 35.20	24.85+a
GROUP 3.....	\$ 31.20	24.85+a
GROUP 4.....	\$ 28.35	24.85+a
GROUP 5.....	\$ 34.50	24.85+a
GROUP 6.....	\$ 34.07	24.85+a
GROUP 7.....	\$ 31.39	24.85+a

a. BOOM LENGTHS, INCLUDING JIBS:

- 150 ft. and over: + \$ 2.00
- 180 ft. and over: + \$ 3.00
- 210 ft. and over: + \$ 4.00
- 240 ft. and over: + \$ 5.00
- 270 ft. and over: + \$ 7.00
- 300 ft. and over: + \$ 8.00
- 350 ft. and over: + \$ 9.00
- 400 ft. and over: + \$10.00

a. PAID HOLIDAYS: New Year's Day, President's Day, Memorial Day, July Fourth, Victory Day, Labor Day, Columbus Day, Veterans Day, Thanksgiving Day & Christmas Day. a: Any employee who works 3 days in the week in which a holiday falls shall be paid for the holiday.

- a. FOOTNOTE: Hazmat work: \$2.00 per hour additional.
Tunnel/Shaft work: \$5.00 per hour additional.

POWER EQUIPMENT OPERATORS CLASSIFICATIONS

GROUP 1: Digging machine, Ross carrier, crane, boomtrucks, lighter, locomotive, derrick, hoist, elevator, bidwell-type machine, shot & water blasting machine, paver, spreader, front end loader (3 yds. and over), vibratory hammer and vacuum truck

GROUP 2: Telehandler equipment, forklift, concrete pump & on-site concrete plant

GROUP 3: Fireman & oiler

GROUP 4: Oiler on crawler backhoe

GROUP 5: Bulldozer, skid steer loaders, bobcats, tractor, grader, scraper, combination loader backhoe, roller, front end loader (less than 3 yds.), street and mobile powered sweeper (3 yds. capacity), 8-ft. sweeper (minimum 65 hp)

GROUP 6: Well point installation crew

GROUP 7: Heater, concrete mixer, stone crusher, welding machine, generator for light plant, gas and electric driven pump & air compressor

IRON0037-001 03/16/2016

Rates Fringes

IRONWORKER.....\$ 34.01 25.22

LABO0271-001 06/05/2016

BUILDING CONSTRUCTION

	Rates	Fringes
LABORER		
GROUP 1.....	\$ 29.20	23.80
GROUP 2.....	\$ 29.45	23.80
GROUP 3.....	\$ 29.95	23.80
GROUP 4.....	\$ 30.20	23.80
GROUP 5.....	\$ 31.20	23.80

LABORERS CLASSIFICATIONS

GROUP 1: Laborer, Carpenter Tender, Mason Tender, Cement Finisher Tender, Scaffold Erector, Wrecking Laborer, Asbestos Removal [Non-Mechanical Systems]

GROUP 2: Asphalt Raker, Adzemen, Pipe Trench Bracer, Demolition Burner, Chain Saw Operator, Fence & Guard Rail Erector, Setter of Metal Forms for Roadways, Mortar Mixer, Pipelayer, Riprap & Dry Stonewall Builder, Highway Stone Spreader, Pneumatic Tool Operator, Wagon Drill Operator, Tree Trimmer, Barco-Type Jumping Tamper, Mechanical Grinder Operator

GROUP 3: Pre-Cast Floor & Roof Plank Erectors

GROUP 4: Air Track Operator, Hydraulic & Similar Self-Powered Drill, Block Paver, Rammer, Curb Setter, Powderman & Blaster

GROUP 5: Toxic Waste Remover

LABO0271-002 06/05/2016

HEAVY AND HIGHWAY CONSTRUCTION

	Rates	Fringes
LABORER		
COMPRESSED AIR		
Group 1.....	\$ 46.63	21.80
Group 2.....	\$ 36.15	21.80
Group 3.....	\$ 48.63	21.80
FREE AIR		
Group 1.....	\$ 38.70	21.80
Group 2.....	\$ 36.15	21.80
Group 3.....	\$ 40.70	21.80
LABORER		
Group 1.....	\$ 29.20	21.80
Group 2.....	\$ 29.45	21.80
Group 3.....	\$ 30.20	21.80

Group 4.....	\$ 22.70	21.80
Group 5.....	\$ 31.20	21.80
OPEN AIR CAISSON, UNDERPINNING WORK AND BORING CREW		
Bottom Man.....	\$ 35.20	21.80
Top Man & Laborer.....	\$ 34.25	21.80
TEST BORING		
Driller.....	\$ 35.65	21.80
Laborer.....	\$ 34.25	21.80

LABORER CLASSIFICATIONS

GROUP 1: Laborer; Carpenter tender; Cement finisher tender; Wrecking laborer; Asbestos removers [non-mechanical systems]; Plant laborer; Driller in quarries

GROUP 2: Adzeperson; Asphalt raker; Barcotype jumping tamper; Chain saw operators; Concrete and power buggy operator; Concrete saw operator; Demolition burner; Fence and guard rail erector; Highway stone spreader; Laser beam operator; Mechanical grinder operator; Mason tender; Mortar mixer; Pneumatic tool operator; Riprap and dry stonewall builder; Scaffold erector; Setter of metal forms for roadways; Wagon drill operator; Wood chipper operator; Pipelayer; Pipe trench bracer

GROUP 3: Air track drill operator; Hydraulic and similar powered drills; Brick paver; Block paver; Rammer and curb setter; Powderperson and blaster

GROUP 4: Flagger & signaler

GROUP 5: Toxic waste remover

LABORER - COMPRESSED AIR CLASSIFICATIONS

GROUP 1: Mucking machine operator, tunnel laborer, brake person, track person, miner, grout person, lock tender, gauge tender, miner: motor person & all others in compressed air

GROUP 2: Change house attendant, powder watchperson, top person on iron

GROUP 3: Hazardous waste work within the "HOT" zone

LABORER - FREE AIR CLASSIFICATIONS

GROUP 1: Grout person - pumps, brake person, track person, form mover & stripper (wood & steel), shaft laborer, laborer topside, outside motorperson, miner, conveyor

operator, miner welder, heading motorperson, erecting operator, mucking machine operator, nozzle person, rodperson, safety miner, shaft & tunnel, steel & rodperson, mole nipper, concrete worker, form erector (wood, steel and all accessories), cement finisher (this type of work only), top signal person, bottom person (when heading is 50' from shaft), burner, shield operator and TBM operator

GROUP 2: Change house attendant, powder watchperson

GROUP 3: Hazardous waste work within the "HOT" zone

 PAIN0011-005 06/01/2015

	Rates	Fringes
PAINTER		
Brush, Roller, Taper, Wall Coverer.....	\$ 31.52	19.35
Epoxy, Tanks, Towers, Swing Stage & Structural Steel.....	\$ 33.52	19.35
Spray, Sand & Water Blasting.....	\$ 32.52	19.35

 PAIN0011-006 06/01/2016

	Rates	Fringes
GLAZIER.....	\$ 35.58	20.15

FOOTNOTES:

SWING STAGE: \$1.00 per hour additional.

PAID HOLIDAYS: Labor Day & Christmas Day.

 PAIN0011-011 06/01/2016

	Rates	Fringes
Painter (Bridge Work).....	\$ 46.95	20.15

 PAIN0035-008 06/01/2011

	Rates	Fringes
Sign Painter.....	\$ 24.79	13.72

 PLAS0040-001 12/01/2015

BUILDING CONSTRUCTION

	Rates	Fringes
CEMENT MASON/CONCRETE FINISHER...	\$ 32.30	26.20
PLASTERER.....	\$ 33.00	25.50

FOOTNOTE: Cement Mason: Work on free swinging scaffolds under 3 planks width and which is 20 or more feet above ground and any offset structure: \$.30 per hour additional.

 PLAS0040-002 07/19/2015

HEAVY AND HIGHWAY CONSTRUCTION

	Rates	Fringes
CEMENT MASON/CONCRETE FINISHER...	\$ 29.10	20.95

 PLUM0051-002 03/01/2016

	Rates	Fringes
Plumbers and Pipefitters.....	\$ 37.38	28.20

 ROOF0033-004 06/01/2016

	Rates	Fringes
ROOFER.....	\$ 34.03	22.34

 SFRI0669-001 04/01/2016

	Rates	Fringes
SPRINKLER FITTER.....	\$ 42.62	20.77

 SHEE0017-002 06/01/2016

	Rates	Fringes
Sheet Metal Worker.....	\$ 34.46	33.53

 TEAM0251-001 08/01/2015

HEAVY AND HIGHWAY CONSTRUCTION

	Rates	Fringes
TRUCK DRIVER		
GROUP 1.....	\$ 26.71	21.3225+A+B+C
GROUP 2.....	\$ 26.86	21.3225+A+B+C

GROUP 3.....	\$ 26.91	21.3225+A+B+C
GROUP 4.....	\$ 26.96	21.3225+A+B+C
GROUP 5.....	\$ 27.06	21.3225+A+B+C
GROUP 6.....	\$ 27.46	21.3225+A+B+C
GROUP 7.....	\$ 27.66	21.3225+A+B+C
GROUP 8.....	\$ 27.16	21.3225+A+B+C
GROUP 9.....	\$ 27.41	21.3225+A+B+C
GROUP 10.....	\$ 27.21	21.3225+A+B+C

FOOTNOTES:

A. Paid Holidays: New Year's Day, Memorial Day, Independence Day, Labor Day, Thanksgiving Day and Christmas Day, plus Presidents' Day, Columbus Day, Veteran's Day & V-J Day, providing the employee has worked at least one day in the calendar week in which the holiday falls.

B. Employee who has been on the payroll for 1 year or more but less than 5 years and has worked 150 Days during the last year of employment shall receive 1 week's paid vacation; 5 to 10 years - 2 weeks' paid vacation; 10 or more years - 3 week's paid vacation.

C. Employees on the seniority list shall be paid a one hundred dollar (\$100.00) bonus for every four hundred (400) hours worked, up to a maximum of five hundred dollars (\$500.00)

All drivers working on a defined hazard material job site shall be paid a premium of \$2.00 per hour over applicable rate.

TRUCK DRIVER CLASSIFICATIONS

GROUP 1: Pick-up trucks, station wagons, & panel trucks

GROUP 2: Two-axle on low beds

GROUP 3: Two-axle dump truck

GROUP 4: Three-axle dump truck

GROUP 5: Four- and five-axle equipment

GROUP 6: Low-bed or boom trailer.

GROUP 7: Trailers when used on a double hook up (pulling 2 trailers)

GROUP 8: Special earth-moving equipment, under 35 tons

GROUP 9: Special earth-moving equipment, 35 tons or over

GROUP 10: Tractor trailer

WELDERS - Receive rate prescribed for craft performing operation to which welding is incidental.

Unlisted classifications needed for work not included within the scope of the classifications listed may be added after award only as provided in the labor standards contract clauses (29CFR 5.5 (a) (1) (ii)).

The body of each wage determination lists the classification and wage rates that have been found to be prevailing for the cited type(s) of construction in the area covered by the wage determination. The classifications are listed in alphabetical order of "identifiers" that indicate whether the particular rate is a union rate (current union negotiated rate for local), a survey rate (weighted average rate) or a union average rate (weighted union average rate).

Union Rate Identifiers

A four letter classification abbreviation identifier enclosed in dotted lines beginning with characters other than "SU" or "UAVG" denotes that the union classification and rate were prevailing for that classification in the survey. Example: PLUM0198-005 07/01/2014. PLUM is an abbreviation identifier of the union which prevailed in the survey for this classification, which in this example would be Plumbers. 0198 indicates the local union number or district council number where applicable, i.e., Plumbers Local 0198. The next number, 005 in the example, is an internal number used in processing the wage determination. 07/01/2014 is the effective date of the most current negotiated rate, which in this example is July 1, 2014.

Union prevailing wage rates are updated to reflect all rate changes in the collective bargaining agreement (CBA) governing this classification and rate.

Survey Rate Identifiers

Classifications listed under the "SU" identifier indicate that no one rate prevailed for this classification in the survey and the published rate is derived by computing a weighted average

rate based on all the rates reported in the survey for that classification. As this weighted average rate includes all rates reported in the survey, it may include both union and non-union rates. Example: SULA2012-007 5/13/2014. SU indicates the rates are survey rates based on a weighted average calculation of rates and are not majority rates. LA indicates the State of Louisiana. 2012 is the year of survey on which these classifications and rates are based. The next number, 007 in the example, is an internal number used in producing the wage determination. 5/13/2014 indicates the survey completion date for the classifications and rates under that identifier.

Survey wage rates are not updated and remain in effect until a new survey is conducted.

Union Average Rate Identifiers

Classification(s) listed under the UAVG identifier indicate that no single majority rate prevailed for those classifications; however, 100% of the data reported for the classifications was union data. EXAMPLE: UAVG-OH-0010 08/29/2014. UAVG indicates that the rate is a weighted union average rate. OH indicates the state. The next number, 0010 in the example, is an internal number used in producing the wage determination. 08/29/2014 indicates the survey completion date for the classifications and rates under that identifier.

A UAVG rate will be updated once a year, usually in January of each year, to reflect a weighted average of the current negotiated/CBA rate of the union locals from which the rate is based.

WAGE DETERMINATION APPEALS PROCESS

1.) Has there been an initial decision in the matter? This can be:

- * an existing published wage determination
- * a survey underlying a wage determination
- * a Wage and Hour Division letter setting forth a position on a wage determination matter
- * a conformance (additional classification and rate) ruling

On survey related matters, initial contact, including requests for summaries of surveys, should be with the Wage and Hour Regional Office for the area in which the survey was conducted because those Regional Offices have responsibility for the Davis-Bacon survey program. If the response from this initial contact is not satisfactory, then the process described in 2.)

and 3.) should be followed.

With regard to any other matter not yet ripe for the formal process described here, initial contact should be with the Branch of Construction Wage Determinations. Write to:

Branch of Construction Wage Determinations
Wage and Hour Division
U.S. Department of Labor
200 Constitution Avenue, N.W.
Washington, DC 20210

2.) If the answer to the question in 1.) is yes, then an interested party (those affected by the action) can request review and reconsideration from the Wage and Hour Administrator (See 29 CFR Part 1.8 and 29 CFR Part 7). Write to:

Wage and Hour Administrator
U.S. Department of Labor
200 Constitution Avenue, N.W.
Washington, DC 20210

The request should be accompanied by a full statement of the interested party's position and by any information (wage payment data, project description, area practice material, etc.) that the requestor considers relevant to the issue.

3.) If the decision of the Administrator is not favorable, an interested party may appeal directly to the Administrative Review Board (formerly the Wage Appeals Board). Write to:

Administrative Review Board
U.S. Department of Labor
200 Constitution Avenue, N.W.
Washington, DC 20210

4.) All decisions by the Administrative Review Board are final.

=====
END OF GENERAL DECISION